



ANCHORAGE SCHOOL DISTRICT

Purchasing Department
4919 Van Buren Street
Anchorage, AK 99517-3137

REQUEST FOR PROPOSAL

THIS IS NOT AN ORDER

Show the following on the outside of the sealed proposal envelope:
**RFP 2024-608 DESIGN SERVICES:
GRUENING MIDDLE SCHOOL BOILER
ROOM UPGRADE**

ISSUED DATE:
January 11, 2024

DUE: **Prior to 10:00 a.m., Local Time**
DATE: **February 2, 2024**

The Anchorage School District (referred to as the “District” or the “ASD”) invites sealed proposals from qualified persons/firms to DESIGN SERVICES: GRUENING MIDDLE SCHOOL BOILER ROOM UPGRADE to the District in accordance with the following documents that are a part of this RFP 2024-608:

Cover Page	This Notice/Cover Page	Page(s) 1 – 2
Section I	Instructions to Offerors	Page(s) 3 – 13
Section II	Evaluation of Proposals	Page(s) 14 – 15
Section III	Proposal Format	Page(s) 16 – 17
Section IV	Specifications and Scope of Services	Page(s) 18 – 22
Attachment A	Proposal Transmittal Form	1 Page(s)
Attachment B	Pre-Audit Statement	1 Page(s)
Attachment C	Sample Formal Professional Services Agreement (FPSA)	56 Page(s)
Attachment D	Gruening Middle School Floor Plan	3 page(s)
Attachment E	Gruening Middle School Mechanical Upgrades Report	6 page(s)
Attachment F	Gruening Middle School Boiler Room Beam Replacement & Upgrades Structural Calculations	10 page(s)
Attachment G	Gruening Middle School Photos of Shoring and Existing Conditions	2 page(s)
Attachment H	Offeror’s Checklist	1 Page(s)
Exhibit 1	Supplemental Terms, Conditions and Forms	7 Page(s)
Exhibit 2	Disadvantaged Business Enterprise (DBE) Contract Participation Form	2 Page(s)
Exhibit 3	Disadvantaged Business Enterprise (DBE) Prime Consultant/Contractor Certification	1 Page(s)
Exhibit 4	Disadvantaged Business Enterprise (DBE) Contract Documentation Form	1 Page(s)
Special Provisions	Disadvantaged Business Enterprise (DBE) Program Specifications for District Contracts	5 Page(s)

THIS RFP HAS FEMA REQUIREMENTS (DISADVANTAGED BUSINESS ENTERPRISE PROGRAM (DBE) PARTICIPATION REQUIREMENTS). DBE PARTICIPATION REQUIREMENTS MUST BE COMPLETED BY THE PROPOSAL SUBMISSION DATE.

AVAILABILITY OF RFP: This Request for Proposals (.pdf) is available electronically at the District’s Purchasing website: <http://asdk12.org/depts/purchasing/>

A copy of the current plan holder’s list can be viewed at:
http://apps.asdk12.org/depts/purchasing/meeting/Plan_Holders/2024/608.xlsx

SUBMISSION OF PROPOSALS: Proposals must be submitted to the Anchorage School District Purchasing Department, 4919 Van Buren Street, Anchorage, Alaska 99517 prior to the time specified above. Proposals received after that time will not be considered and will be returned. FAXED or ELECTRONIC proposals are not acceptable. Proposals must be submitted in a SEALED package with the outside of the package clearly marked with Offeror's name, address, and phone number, and as follows:

REQUEST FOR PROPOSALS 2024-608
DESIGN SERVICES: GRUENING MIDDLE SCHOOL BOILER ROOM UPGRADE
DUE: Prior to 10:00 a.m., Local Time
DATE: February 2, 2024

ON-SITE VISIT: A pre-proposal on site-visit will be held at 3:00 p.m., Local Time, January 17, 2024 at Gruening Middle School, 9601 Lee St., Eagle River, AK 99577. Prospective proposers are encouraged to meet the ASD Project Manager at the School's main office entrance and walk through the proposed area of design for this RFP.

PRE-PROPOSAL CONFERENCE: A pre-proposal conference will be held at 10:00 a.m., Local Time, January 18, 2024, in the conference room of the Anchorage School District Purchasing Department, 4919 Van Buren Street, Anchorage, Alaska to discuss any matter concerned with this RFP. ***Prospective Offerors are encouraged to participate by teleconference by calling (907) 742-6750. The line will be available approximately 5 minutes' prior the conference start time.***

The Anchorage School District is committed to providing reasonable accommodations, according to applicable state and federal laws, to all individuals with a qualifying disability. If you require a reasonable accommodation in order to participate in this or any other district process, please contact the Anchorage School District's Compliance/Equal Employment Opportunity Office (907) 742-4132.

Estimated amount of proposed contract: \$200,000 - \$300,000

END OF COVER PAGE

A. GENERAL REQUIREMENTS

This solicitation is a REQUEST FOR PROPOSALS (“RFP”) governed by applicable Anchorage School Board Policies, including Section 3311 of such Policies. Anchorage School Board Policies are available at <https://www.boardpolicyonline.com/?b=anchorage>

Offerors should read this RFP carefully and review all instructions contained herein. Incomplete or incorrect proposals may be rejected as not conforming to the essential requirements of the RFP. Proposals submitted on other than the prescribed forms contained in this RFP will be rejected. Offerors may copy the forms contained in the RFP for use in their proposals, but substitute forms or formats are unacceptable. Electronic copies of the forms which offerors must submit as part of any proposal, if any—if not provided with this RFP—may be obtained by contacting the Anchorage School District Purchasing Department. Forms shall not be altered except to supply requested offeror information.

B. INTENT OF SPECIFICATIONS

The Anchorage School District desires to enter into a contract with an offeror whose primary business is to provide professional design services to upgrade the boiler room at Gruening Middle School and to complete the contract in accordance with all of its terms and conditions and in compliance with all applicable laws. The scope of work is considered performance oriented and it is the intent of the District to rely on the experience and expertise of the offeror to fully appraise itself of the work required to fulfill the terms of the contract resulting from the RFP.

C. EXAMINATION OF CONTRACT DOCUMENTS

Offerors should read this Request for Proposals carefully and review all instructions contained herein. The submission of a proposal shall constitute acknowledgement that the offeror has thoroughly examined and is familiar with the solicitation documents.

D. CONDITIONS OF THE WORK

Each offeror must acquaint itself thoroughly as to the character and nature of the services to be provided to fulfill the requirements of the resulting contract. Each offeror must complete a careful examination of the existing systems, infrastructure, geographical features, and prevailing weather conditions, as applicable, and must inform itself fully as to the difficulties to be encountered in the performance of the work, the availability of a qualified work force and other conditions related to providing the required services. No claim of ignorance of conditions that exist or hereafter may exist, or difficulties that may be encountered in the execution of the work, as a result of failures to make necessary investigations and examinations, will be accepted as an excuse for any failure or omission on the part of a successful offeror(s) to fulfill all of the requirements of the contract documents and to complete the work for the consideration set forth therein, or as the basis for any claim whatsoever.

E. QUESTIONS; METHOD FOR CLARIFICATION

Any offeror in doubt as to the true meaning of any part of this RFP may submit to the District a written request for an interpretation thereof. Questions must be received by the District’s Purchasing Department at least seven (7) days prior to the date set for the submission of proposals. If such date falls on a weekend or holiday, the deadline shall be the last business day before the weekend or holiday. Questions can be delivered as follows:

Fax: Anchorage School District Purchasing Department @ 907-243-6293
Attn: Shannon Powers, Sr. Purchasing Agent
Reference: RFP 2024-608 DESIGN SERVICES: GRUENING MIDDLE SCHOOL
BOILER ROOM UPGRADE

E-mail: purchasing@asdk12.org *PREFERRED METHOD*
Attn: Shannon Powers, Sr. Purchasing Agent
**Reference: RFP 2024-608 DESIGN SERVICES: GRUENING MIDDLE SCHOOL
BOILER ROOM UPGRADE**

Mail: Anchorage School District Purchasing Department
Attn: Shannon Powers, Sr. Purchasing Agent
4919 Van Buren Street
Anchorage Alaska 99517-3137
Reference: RFP 2024-608 DESIGN SERVICES: GRUENING MIDDLE SCHOOL
BOILER ROOM UPGRADE

Two types of questions generally arise. One may be answered by directing the offeror to a specific section of the RFP. These questions may be answered by direct communication to the offeror submitting the question. Questions which in the opinion of the Purchasing Senior Director require a more detailed or complex reply, or require an answer that may affect responses to this RFP or may be prejudicial to other prospective offerors, will be answered by issuing an addendum to all RFP holders prior to the submittal opening.

F. ERRORS AND AMBIGUITIES

1. Offeror comments concerning discrepancies, defects, ambiguities or other errors in the RFP must be made in writing and received by the District's Purchasing Department at least seven (7) days prior to the date set for the submission of proposals. If such date falls on a weekend or holiday, the deadline shall be the last business day before the weekend or holiday. Comments can be delivered as set forth in Section E, above. Any clarifications, changes or corrections to the RFP will be made only by written notice or addendum issued by the District.
2. If an offeror fails to notify the District of a discrepancy, defect, ambiguity or other error in the RFP, the offeror's proposal shall be submitted at the offeror's own risk and if a contract is awarded as a result of such proposal, the offeror shall not be entitled to additional compensation or other consideration by reason of the discrepancy, defect, ambiguity or other error, or its later correction or clarification. Protests based on any error or omission, or on the content of the solicitation, will be disallowed if the fault has not been brought to the attention of the District, in writing, at least five (5) days prior to the date set for submission of proposals. If such date falls on a weekend or holiday, the deadline shall be the last business day before the weekend or holiday.

G. ADDENDA

Addenda may be issued when changes, clarifications, or amendments to this RFP are deemed necessary by the District for any reason. If an addendum is issued, the District will make reasonable efforts to ensure that each prospective offeror receives the addendum in a timely fashion. However, the risk of non-receipt of any addendum lies solely with prospective offerors. Offerors should contact the District at the addresses set forth in Section E, above, to ascertain if any addenda have been issued. Offerors must acknowledge receipt of each addendum issued in the space provided on the appropriate addendum form and submit such signed addendum with the proposal. No oral change or interpretation of this RFP shall be relied upon by prospective offerors or shall be binding on the District whether issued at a pre-proposal conference or otherwise.

H. SUBMISSION OF PROPOSALS

1. All proposals, addenda, and forms must be manually signed. **One (1) original and five (5) copies of the proposal, for a total of six (6).**

2. Proposals delivered by telefax, facsimile or by electronic means are not acceptable and will not be considered.
3. Signed and sealed Proposals must be at the District Purchasing Department on or before the time and date stated on the face page of this RFP. Offerors are solely responsible for ensuring that the offeror's proposal package is received by the District's Purchasing Department by the deadline.
4. Late proposals will not be considered and will be returned to the offeror unopened.
5. Photographs may be included with a proposal as appropriate or as desired by the offeror. Photographs will not be returned to an offeror.
6. Offerors may submit only one proposal for evaluation.
7. No responsibility will attach to any officer or agent of the District for the premature opening of, or the failure to open, a proposal not properly addressed and identified.

I. ALASKA BUSINESS LICENSE

Offerors must hold a valid Alaska business license and any necessary applicable professional licenses required by Alaska Statute as a condition of award. Offerors should contact the State of Alaska, Department of Commerce, Community and Economic Development, Division of Occupational Licensing, for information regarding business licensing. Contact information, information regarding business licensing, and business licenses, are available at <http://www.dced.state.ak.us/occ>.

J. FIRM OFFER

Offers made in response to this RFP must be good and firm for a period of ninety (90) calendar days from the date specified for submittal of proposals.

K. WITHDRAWAL OF PROPOSALS

Proposals may be withdrawn on written request delivered to the District Purchasing Director (fax is acceptable) prior to the time specified for submittal. Proposals not withdrawn prior to the specified time may not be withdrawn for a period of ninety (90) calendar days after the time for receipt of proposals.

L. DISTRICT NOT RESPONSIBLE FOR PREPARATION COSTS

Each offeror understands and agrees that it submits its proposal at its own risk and expense and releases the District from any claim for damages or other liability arising out of the Request for Proposals and award process, including but not limited to: proposal preparation costs and costs associated with any challenge (administrative, judicial or otherwise (including attorney fees)) to the determination of the highest ranked proposal and/or award of contract and/or rejection of proposals, except as follows: in the event that a contract is awarded to one offeror, and it is determined after award of the contract that it should have been awarded to some other offeror, the only financial liability of the District, if any, to the aggrieved offeror shall be actual costs reasonably incurred by that offeror in the preparation and submittal of its proposal. No other obligation of any sort is created nor may liability, financial or otherwise, be asserted against the District, its Board, Board members, employees, agents or insurers to offer to award or award a contract. By submitting a proposal, each offeror agrees to be bound in this respect.

M. REJECTION OF PROPOSALS

Instructions to Offerors
Section I

1. Offerors must comply with all of the terms of this RFP, and all applicable local, state, and federal laws, codes and regulations. The District may reject any proposal that does not comply with all of the material and substantial terms, conditions, and performance requirements of this RFP and any proposal which contains information or material which cannot be verified or otherwise confirmed for purposes of determining responsiveness to the solicitation.
2. The District reserves the right to waive informalities and minor irregularities, and/or reject any and all proposals, and to not award the proposed contract, if in its best interest. "Informalities and minor irregularities" means matters of form rather than substance which are evident from the submittal, or are insignificant matters that have a negligible effect on price, quantity, quality, delivery, or contractual conditions and that can be waived or corrected without prejudice to other Offerors. These include items that:
 - Do not affect responsiveness;
 - Are merely a matter of form or format;
 - Do not change the relative standing or otherwise prejudice other offers;
 - Do not change the meaning or scope of the RFP;
 - Are trivial, negligible, or immaterial in nature;
 - Do not reflect a material change in the work, or;
 - Do not constitute a substantial reservation against a requirement or provision of the RFP.

N. SELECTION FOR AWARD

1. Selection for award will be accomplished in accordance with Anchorage School Board Policy Section 3311 and the terms and conditions of this solicitation. A recommendation for award, based upon the evaluation criteria specified in this RFP, will be made to the Anchorage School Board for approval, unless approval is not required under Board Policy Section 3311.
2. The District may award a contract on the basis of initial proposals received, without discussions. Therefore, each proposal should contain the offeror's best efforts from a technical standpoint.
3. For those awards requiring Board approval, the District's Purchasing Department will make public in the Purchasing Department each Notice of Intent to Award ten (10) calendar days prior to the scheduled date for award by the Board. Offerors may, upon request to the Purchasing Department, review the proposal scoring summary prior to the scheduled Board award date.
4. Any contract awarded as a result of this solicitation will incorporate the contents of this RFP and the successful offeror's proposal, subject to the reservations set forth herein for provisions of a proposal that do not comply with material and substantial terms, conditions, and requirements of this RFP or that impermissibly restrict the rights of the District. The successful offeror(s) will be required to execute a written contract in the form included as part of this RFP and comply with its terms.

O. NEGOTIATIONS

After final evaluation, the District may negotiate with the offeror of the highest-ranking proposal. Negotiations, if held, shall be within the scope of the RFP and limited to those items which would not have an effect on the ranking of proposals. The District reserves the right to change terms and conditions during contract negotiations. If the highest-ranked offeror fails to provide necessary information for negotiations in a timely manner or fails to negotiate in good faith, or if the offeror and the District, after a good faith effort, cannot come to terms, the District may terminate negotiations and commence negotiations with the offeror of the next highest-ranking proposal.

P. REQUIREMENTS FOR SUBMISSION OF COST/PRICING DATA

This project requires the submission of certified cost/pricing data. An audit, conducted by the offeror, of the selected offeror's cost accounting systems and business records may be required to ascertain if systems are adequate for School District review; and to investigate the accuracy of proposed labor rates and unit prices.

- 1. The selected firm shall prepare and submit the PRE-AUDIT STATEMENT as contained in Attachment B with their cost/price proposal. ASD reserves the right to review requested supporting documentation and/or institute a site visit.***
- 2. The firm selected for negotiations shall be required to submit a detailed breakout for each task and all the direct costs included in the scope of work. The information shall include the estimated hours to perform each task and include the labor category necessary to complete the task.***
- 3. A detailed price sheet of unburdened labor costs by labor category shall be submitted. However, if the offeror has been audited within the last 2 years by a government agency, or provided by an auditing firm, that has approved a fully loaded labor rate for all categories of labor included in the cost proposal, ASD will review such data for consideration.***
- 4. If the offeror's Indirect Costs have not been previously audited by a government agency, ASD may, in its sole discretion, require an on-site audit of the offeror's financial records for the purposes of approving a project Indirect Cost Rate to apply to any resulting contract.***
- 5. Provide a proposed fee or profit margin to apply to the project along with an explanation as to the appropriateness of the fee/profit as it relates to the project risks and deliverables.***

Q. RESPONSIBLE OFFERORS

1. A contract will be awarded only to prospective offerors who are determined to be responsible.
2. In order to determine responsibility of a prospective offeror, the District may require offerors to supply additional information or documentation and may perform on-site pre-award surveys. Failure of an offeror to promptly cooperate or supply information in connection with a District inquiry with respect to responsibility may result in a determination of non-responsibility with respect to the offeror.
3. To be determined responsible, a prospective offeror must:
 - a. Have adequate financial resources to perform the contract or the ability to obtain them;
 - b. Be able to comply with the contract performance schedule taking into consideration all existing other business commitments;
 - c. Have a satisfactory performance record;
 - d. Have a satisfactory record of integrity and business ethics;
 - e. Have the necessary organization personnel, experience, accounting and operational controls, and technical skills, or the ability to obtain them;
 - f. Have the necessary equipment and facilities or the ability to obtain them; and

Instructions to Offerors
Section I

- g. Be otherwise qualified and eligible to receive an award under applicable laws and regulations.

R. AWARD OF CONTRACT

1. Award of Contract

- a. Selection of the successful offeror will be by a notice in writing signed by a duly authorized representative of the District and no other act of the District or its representative will constitute an acceptance of a proposal.

2. Execution of Contract

- a. The offeror whose proposal is accepted by the District shall execute the contract and furnish the required insurance within five (5) days after presentation of the contract for signature. Failure or neglect to provide the required insurance or to execute the contract within the time specified, or within such additional time as the District, in its sole discretion, may allow, shall constitute a breach of the agreement affecting the award. The damages to the District for such breach shall include loss due to delay and interference with the District's general operations improvements program, and increased administrative expense, and other items whose accurate amount would be difficult or impossible to compute.
- b. Upon receipt of the above-referenced contract executed by the offeror, and all required insurance certificates, the properly authorized District representatives will execute the contract. The Contract shall not be effective until it is executed by a properly authorized representative of the District.

S. AGGRIEVED OFFERORS

1. Protest

- a. An interested party may protest a solicitation or a proposed award of a contract.
 - i. A protest as to the specifications and/or terms and conditions of a solicitation must be received by the Purchasing Senior Director at least five (5) calendar days prior to the due date of the bid or proposal; failure to protest as provided herein constitutes a waiver of any objection to the solicitation.
 - ii. For construction projects and architectural/engineering design services, the protest of a proposed award of a contract must be received by the Purchasing Senior Director within ten (10) calendar days after issuance of the Notice of Intent to Award.
 - iii. For goods or services, the protest of a proposed award of a contract must be received by the Purchasing Senior Director within seven (7) calendar days after issuance of the Notice of Intent to Award, except that for purchases under \$100,000, the protest must be received within three (3) business days.
 - iv. The protest must include the name of the person submitting the protest, the name of the bidder/proposer represented by that person, the specific action or bid/request for proposal contract award which is being protested, a detailed explanation of the reasons for the protest, and the relief requested.
 - v. The aggrieved person must serve all other interested parties with its protest.

- b. The Purchasing Senior Director shall stay the intended award of a contract unless the Purchasing Senior Director determines the award of the contract without further delay is necessary to protect the District's best interest.
 - c. The Purchasing Senior Director may, in his/her sole discretion, hold a hearing.
 - d. The rights and remedies granted by this section are not available for informal small purchases with an actual or potential value of less than twenty-five thousand dollars (\$25,000).
 - e. Failure to protest as provided herein constitutes a waiver of any objection to the solicitation and contract award.
2. Appeal
- a. A decision by the Purchasing Senior Director may be appealed to the Anchorage School Board.
 - b. Any appeal shall be filed with the Superintendent within five (5) days after the decision is received by the protester and must include the name of the person submitting the appeal, the name of the bidder/proposer represented by that person, and a detailed explanation of the basis for the appeal.
 - c. The aggrieved bidder/proposer must serve all other interested parties with its appeal.
 - d. The Superintendent may obtain an independent review of the appeal issues if the Superintendent determines such review will assist consideration of the appeal.
 - e. The independent review shall not be conducted by a District employee, but must be conducted by an experienced but disinterested third party from outside the District.
 - f. Failure to appeal to the Anchorage School Board as provided herein constitutes a waiver of any objections to the solicitation and the contract award.
3. Consideration of Appeal
- a. The decision being appealed and the findings from the independent review, if any will be reported to the Board.
 - b. Upon consideration of the appeal and allowing interested parties an opportunity to address the issues on appeal, the Board may:
 - i. Award the contract as recommended, if applicable, indicating its reasons for rejecting the appeal;
 - ii. Grant the appeal, indicating its reasons for granting the appeal, and determine an appropriate remedy consistent with AR3311.1(c).1 of Board Policy. The Board may award the contract at that meeting to some other bidder/proposer if it finds that a delay in making the award would adversely affect the District.
 - iii. Stay any award of the contract to permit further consideration of the appeal, with action to be scheduled as soon as practicable, but in no event more than twenty (20) days after the stay as initiated.
 - iv. Reject all bids/proposals

Instructions to Offerors
Section I

- v. Take such other action as appears appropriate and in the best interest of the District under the circumstances.
4. Frivolous Protests
 - a. Signature on Protest Constitutes Certificate
 - i. The signature of an attorney or party on a request for review, protest, motion, or other document constitutes a certificate by the signer that the signer has read the document, to the best of his/her knowledge, information, and belief formed after reasonable inquiry it is well grounded in fact and is warranted by existing law or a good faith argument for the extension, modification, or reversal of existing law, and that it is not interposed for an improper purpose, such as to harass, limit competition, or to cause unnecessary delay or needless increase in the cost of the procurement or of the litigation.
 - b. Sanctions for Violation
 - i. If a request for review, protest, pleading, motion, or other document is filed with the Purchasing Senior Director is signed in violation of Board Policy AR3311.1(c).1, the School Board may impose upon the person who signed it, a represented party, or both, an appropriate sanction, that may include an order to pay to the other party or parties the amount of the reasonable expenses incurred because of the filing of the protest, pleading, motion, or other paper, including a reasonable attorney's fee.

T. PUBLIC RECORDS/CONFIDENTIALITY

1. This RFP and the resulting proposals received, together with copies of all documents pertaining to the award of a contract, will be kept by the District's Purchasing Office and made a part of the record which will be open to public inspection after contract award. Proposers, upon request to the Purchasing Officer, may review the proposal scoring summary after issuance of the notice of intent to award has been issued, except to the extent permissibly restricted by the offeror.
2. Offerors are advised to consult School Board Policy Section 1340 and the Alaska Public Records Act, A.S. 40.25.100-40.25.295 to verify if any of their proposal information may qualify for exemption from public disclosure. Exemptions to public disclosure requirements are narrowly construed. As such, the District cannot exempt materials that are not of a truly proprietary nature under applicable law and policy, and cannot be held liable for the disclosure of such information, even if marked for restriction by an offeror.
3. If a proposal contains any information that an offeror reasonably believes is proprietary or confidential, and is subject to protection under applicable law, each such page of the proposal must be marked "Confidential" by the offeror and the offeror must explain the basis for its determination that the information is not subject to disclosure under applicable public records laws. Cost or price information may not be restricted and will be open to public inspection. Marking an entire proposal "confidential" is not acceptable and may result in disclosure of the entire proposal.
4. By submitting a proposal, the offeror agrees to release the District from any liability resulting from the District's disclosure of information not clearly marked "Confidential." The offeror also agrees to defend any action seeking release of information marked "Confidential" and to indemnify and hold the District, its Board, employees and agents, harmless from any judgments, damages and costs awarded against the District, its Board, employees or agents, in favor of a party requesting information submitted by an offeror. Additionally, the offeror understands and agrees that if a request is made under applicable public records laws, the

District will notify the offeror of such request but under no circumstance shall the District be required to commence or defend any action to prevent the disclosure of any information submitted by an offeror, including information the offeror believes to be confidential or proprietary.

U. EQUAL EMPLOYMENT OPPORTUNITY

1. The Contractor certifies that it will not discriminate against any employee or applicant for employment because of race, color, religion, national origin, ancestry, age, sex, marital status, mental or physical disability, or change in marital status, in employment, provision of services or otherwise. The Contractor shall take affirmative action to ensure such non-discrimination, including but not limited to the following: employment, upgrading, demotion, transfer, recruitment or recruitment advertising, layoff or termination, rates of pay or other forms of compensation, and selection for training including apprenticeship. The Contractor shall post in conspicuous places, available to employees and applicants for employment, notices setting forth the provisions of this nondiscrimination clause.
2. The Contractor shall state, in all solicitations or advertisements for employees to work in the performance of this Agreement, that all qualified applicants will receive consideration for employment without regard to race, color, religion, national origin, ancestry, age, sex, marital status, mental or physical disability, or change in marital status.
3. The Contractor shall comply with the requirements of the Anchorage Municipal Code, Chapter 7.50.010-.120, as well as any procedures adopted by the District to implement the policies set forth therein.
4. The Contractor shall comply with any and all of the applicable laws and directives, and any regulations which may be applicable to the Project or this Agreement.
5. The Contractor shall include the provisions of this Article in every Subcontract and purchase order, and shall require each Subcontractor to include these provisions in every sub-subcontract, so that these provisions will be binding upon each Subcontractor, sub-subcontractor and vendor providing services or goods to the Project.
6. The Contractor shall cooperate fully with the District's efforts which seek to deal with the problem of unlawful discrimination, and with all other District efforts to guarantee fair employment practices under this contract and promptly comply with all requests and directions from the Anchorage Equal Rights Commission and State Commission for Human Rights or any of its officers or agents relating to prevention of discriminatory employment practices.

V. NON-DISCRIMINATION

1. No Contractor on any District contract may illegally discriminate on the basis of sex, race, color, religion, gender identity, sexual orientation, national origin, ancestry, age, marital status, changes in marital status, pregnancy, parenthood, physical or mental disability, Vietnam era veteran status, genetic information, or good faith reporting to the board on a matter of public concern in employment, provision of services, or otherwise.
2. Any Contractor submitting a bid or proposal of one hundred thousand (\$100,000) or more must certify that if awarded a contract on the basis of that bid or proposal, he/she as the contractor will not illegally discriminate against any member or applicant for employment because of sex, race, color, religion, gender identity, sexual orientation, national origin, ancestry, age, marital status, changes in marital status, pregnancy, parenthood, physical or mental disability, Vietnam era veteran status, genetic information, or good faith reporting to the board on a matter of public concern in employment, provision of services, or otherwise.

W. NOTICE OF COMPLIANCE

1. All successful Contractors shall ensure such non-discrimination.
2. All successful Contractors must agree to post in conspicuous places, available to employees and applicants for employment, notice setting forth the provisions of this non-discrimination section and this section shall be deemed to be a part of every contract entered into by the District under these policies.

X. CONFLICT OF INTEREST

1. The Contractor agrees to certify that Anchorage School District employees, School Board members, or a member of their household are not in conflict of interest with the contract and Board Policy as follows (AR3311.1(e).1 Disclosure and Waiver of Conflict of Interest):
 - a. No Board member, employee, or a member of their household, shall acquire, directly or indirectly, an economic interest in a District or Municipal contract, or engage in business with the District or the municipality, unless the contract is competitively solicited and other requirements of Section 3311 of Board Policy and section 1.15 of the Anchorage Municipal Code are met.
 - b. The following acts and circumstances shall not be deemed to be in conflict with the performance of official duties if, at the earliest opportunity after having acquired such knowledge, the Board member or employee files a disclosure pursuant to AR3311.1(e).1 or requests and obtains a waiver pursuant to Board Policy AR3311.1(e).2:
 1. Such person owns a sole proprietorship, or is a partner in a partnership, or is an officer, director, major shareholder (five percent (5%) or more of the outstanding shares) or has management control in a corporation that submits a bid, proposal or quotation to the District or attempts to enter or enters into a contract with the District;
 2. Such person has any significant (five percent (5%) or more) financial interest in any sale, lease or rental to the District of any service or property and such person has knowledge that the District intends to purchase, lease or rent the property or service;
 3. Such person wishes to sell or receive royalties on books or materials sold to the District for use in the school system for which the employee is the author;
 4. Such person is an employee who has been providing private services to a child who transfers to a new school or class or advances to a higher grade and the child becomes a student in the class being taught/aided by his/her provider.
2. Board Members, District employees, and their household and/or immediate family members are required to comply with Board Policies and the Municipal Ethics Code by disclosing conflicts of interest.
 - a. When a board member, employee, or their household and/or immediate family member intends to do business with the District, the appropriate District and Municipal forms must be filed by the Board Member or District employee with the Municipal Clerk's Office and the Purchasing Department.

Note: *Notice of Intent To Respond To Public Solicitation* shall be filed with the Municipal Clerk's office in advance to allow a minimum of **7 calendar days to elapse between electronic publication by the clerk and the final date** for submitting a response to the solicitation. The form may be obtained from the Municipality of Anchorage website, www.muni.org.

District *Disclosure* and *Request for Waiver* forms and instructions may be obtained from the Conflict of Interest link on the Procurement Department page of the ASD website, www.asdk12.org.

- b. The responsibility for complete and timely filing rests solely with the Board Member or District employee.

Y. SEX OFFENDER/CHILD KIDNAPPER REGISTRY

Anchorage School Board Policy 3515.5 prohibits a contractor whose employees or agents may have direct or incidental contact with District students from sending any employee or agent to district property who has been convicted of a sex offense under federal law or the law of any state and who is required to register as a sex offender under Alaska law or by court order, or who has been convicted of child kidnapping under federal law or the law of any state and who is required under Alaska law or court order to register on the Alaska Department of Public Safety Sex Offender/Child Kidnapper Central Registry. Board Policy 3515.5 requires contractors to certify in writing the contractor's knowledge of and compliance with Board Policy 3515.5. **Prior to executing a contract** for this project, the selected Contractor shall verify that no employee or agent who will be on district property is registered as a sex offender or child kidnapper in Alaska [Alaska Department of Public Safety "Sex Offender/Child Kidnapper Registry"] or in any other state. In addition, the contractor shall certify that, to its knowledge, no employee or agent is a convicted sex offender or child kidnapper. Certification will be required at time of award.

Z. CONTACT WITH SCHOOL STAFF AND AUTHORIZED SCHOOL COMMUNITY GROUPS

Offeror is not to contact site's school staff or authorized community groups for purposes of solicitation unless otherwise authorized by the Purchasing Senior Director.

AA. CONTRACT INDUCEMENTS

No payment, gratuity or offer of employment shall be made in connection with any contract, by or on behalf of the subcontractor to the prime contractor or higher tier subcontractor or any person associated therewith, as an inducement for the award of a subcontract or order.

BB. STANDARD CONTRACT TERMS

In addition to carefully reading all of the information in the RFP, Offerors must carefully read and review the attached standard contract terms and conditions. The successful Offeror shall be required to enter into an agreement with the District which will be substantially similar to the sample.

END OF SECTION I

A. EVALUATION OF PROPOSALS

1. All proposals will be reviewed by the District's Purchasing Department to evaluate administrative responsiveness of proposals to determine if offerors have complied with the administrative proposal requirements and to determine if proposals meet the minimum mandatory criteria set forth below.
2. Proposals meeting minimum mandatory requirements then will be evaluated by an evaluation committee comprised of District employees or other persons deemed appropriate by the District using the Evaluation Criteria specified in this RFP. Evaluation of proposals in accordance with the evaluation criteria will result in a numerical score for each proposal. Each criterion has an assigned weight for this RFP which demonstrates its relative importance. Evaluation of proposals will be accomplished as follows:

- a. Each Evaluator will individually review and score each offeror's proposal on a scale of 0 to 1 for each of the Technical Evaluation Criteria.

A rating of "0" indicates a proposal which is non-responsive and/or provides no quality or value to the District and a rating of "1.0" indicates a proposal which is completely responsive and/or provides significant quality and value to the District. Ratings within the range indicate the level at which the proposal is responsive and/or provides quality and value to the District.

- b. After completion of ratings by each Evaluator, the Selection Committee may discuss the proposal. Evaluators may then alter their ratings; however, any changes shall be based only on the proposal and the Evaluation Criteria.
- c. The chairperson will obtain the ratings for the Evaluation Criteria, which ratings will then be multiplied against the points available for each criterion. The sum of the weighted scores for each proposal will result in a total weighted score from each member of the evaluation committee. The total weighted scores of all Evaluators will be summed to determine the total weighted score for each proposal. The maximum score obtainable for any proposal is equal to the product of the maximum points for the evaluation criteria multiplied by the number of Evaluators.
- d. Based upon the results of the proposal scoring, the District may, in its discretion, conduct discussions with offerors whose proposals are determined to be reasonably susceptible to award. Such discussions, visits and presentations are for the purpose of ensuring full understanding of the requirements of the RFP and offeror proposals and may not result in any material or substantive change to proposals. Offerors selected by the Selection Committee for interviews may be permitted to submit final written, graphic and verbal presentation information for consideration by the Selection Committee in response to the above purposes. Only those members of the offeror's staff who will be in responsible charge and/or will carry out the actual tasks should participate in the interviews.
- e. Subsequent to the interviews, the Selection Committee will make a final rating based upon the original criterion supplemented by interview information for the purposes of determining the highest ranked proposer. The Selection Committee shall use the same procedure as specified for the initial proposal rankings. The final ranking may or may not be the same as the order of ranking after completion of the initial ranking.
- f. For purposes of this RFP, proposals that are "reasonably susceptible to award" means the three (3) highest scoring proposals, unless, in the sole discretion of the District's Purchasing Senior Director, one or more of the three highest scoring proposals did not achieve a score high enough to be within the competitive range and to remain under consideration for award when ranked with other proposals or the District received one or

more additional proposals that are within the competitive range of the three highest scoring proposals such that the additional proposal(s) may remain under consideration when ranked with the other proposals. This is not a strict mathematical formula and may not be challenged on that basis except in the case of obvious arithmetic errors.

3. The District reserves the right, at any time, to determine that a proposal is non-responsive and to request additional information to determine responsiveness.
4. All Offerors will be advised of the offeror selected for negotiation with a Notice of Intent to Negotiate. If contract negotiations are unsuccessful with offeror selected for negotiation, the School District may either cancel the solicitation or negotiate with other offerors in the order of ranking.

B. EVALUATION CRITERIA

Proposals will be scored using the criteria listed below to determine which proposal best meets the needs of the Anchorage School District. The criteria to be considered during the evaluation and their associated weights are as follows:

Item	Criteria	Points
1.	PROJECT APPROACH	25
2.	METHODS	20
3.	MANAGEMENT	10
4.	FIRM'S EXPERIENCE	20
5.	PROPOSED PROJECT STAFF	10
6.	WORKLOAD AND RESOURCES	15
	TOTAL POINTS POSSIBLE	100

END OF SECTION II

Each response must be identified and keyed to the applicable criterion and assembled in the order in which the criteria are listed in Section II, Part B, so the criterion to which information applies shall be plainly evident. Material not so identified or assembled may be discarded without evaluation. Each proposal shall be submitted on standard 8 1/2" x 11" bond paper bound on one side. Proposals should be prepared simply and economically, providing a straightforward, concise delineation of the capabilities proposed to satisfy the requirements of this RFP. In addition, small print or typeface that is difficult to read may affect scoring.

To achieve a uniform review process and obtain the maximum degree of comparability, it is required that the proposals be organized in the manner specified below. **Proposals shall not exceed twenty-five (25) pages in length** (excluding letter of transmittal, resumes (resumes shall not exceed two (2) pages in length), table of contents, attachments, or dividers. Information in excess of those allowed will not be evaluated or scored. One page shall be interpreted as one side of single lined, typed, 8 1/2" X 11", piece of paper.

To ensure that proposals are evaluated fairly and that comparisons between proposals are accurate, Offerors must submit proposals in the format outlined below. Failure to comply with these requirements may cause a proposal to be rejected as non-responsive and eliminated from further consideration.

A. PROPOSAL TRANSMITTAL FORM

Submit the completed Proposal Transmittal Form (Attachment A) as the first page of the proposal. The Proposal Transmittal Form must be signed by an authorized representative of the offeror.

B. PROPOSAL NARRATIVE

1. PROJECT APPROACH

Weight:

Restate the proposed Scope of Services, outlining the objectives and scope as perceived. Do not repeat the statement of services provided herewith, but elaborate on the tasks, conditions, deliverables or other specifics deemed significant and necessary to demonstrate a complete understanding of the technical and substantive issues to be addressed. Define any assumptions made in formulating response. If scope includes design services for a construction project, express any opinions regarding alternative design considerations that could impact construction costs.

2. METHODS

Weight:

Response must outline the methods for accomplishing the proposed contract. Consider what, when, where, how, and in what sequence the work will be done. Include proposed timeline with milestones. Identify the amount and type of work to be performed by any sub-consultants. Consider how each task may be carried out; what services or interaction may be required from/with the Contracting Agency. Suggest alternatives, if appropriate. Identify any distinct and substantive qualifications for undertaking the proposed contract, such as the availability of specialized equipment or unique approaches or concepts relevant to the required services, which the firms may use.

3. MANAGEMENT

Weight:

Response must describe the administrative and operational structures that will be used for performing the proposed contract. Address who will have overall responsibility for the contract and who will have direct responsibility for specific disciplines. Discuss the lines of authority. Use of a table or chart is preferred in your response. When applicable, include discussion of public participation process and coordination with State and Municipal agencies.

4. FIRM'S EXPERIENCE

Weight:

Discuss the offeror's background and qualifications to establish experience and performance as a team leader for professional services similar to those required by this project. Discuss the relevance of past projects (program, unique features, schedules, budgets, etc.) to this project. List at least three (3) references (contact persons and telephone numbers) for the firm.

5. PROPOSED PROJECT STAFF

Weight:

Response must name proposed leader(s) for the following categories plus any other essential personnel who will be directly and routinely engaged in performing the work:

1 – Principal-in-Charge	3 – Project Manager	5 – Mechanical Engineer
2 – Contract Manager	4 – Project Architect/Planner	6 – Structural Engineer

Describe the work to be performed by the named Leader(s), and their qualifications in terms of educational and substantive experience directly related to the proposed services. Identify: employer, professional discipline and/or job classification, Alaskan registration number, and state of residency. A response prepared specifically for this proposal is required. Marketing resumes often include irrelevant information, which may detract from the evaluation of proposal. Lists of projects without relevant details are not useful. Focus on individuals' specific duties and responsibilities and how project experience is relevant to the proposed services.

6. WORKLOAD AND RESOURCES

Weight:

Response must: (1) discuss both current and potential time commitments to all clients (i.e. not only the District) for the proposed Project Staff; and (2) demonstrate adequate support personnel, facilities and other resources to provide the services required throughout the project's term. Briefly address capabilities for providing additional services and/or services under an accelerated schedule. Address capacity to reassign personnel, equipment and facilities whenever the proposed contract would not require such capabilities or would be delayed.

END OF SECTION III

A. SCOPE OF WORK

1. The requirements of this project shall consist of providing complete design services necessary to support the upgrades to the existing boiler room at the location identified below.

- a. Gruening Middle School, 9601 Lee St., Eagle River, AK 99577

The Prime Consultant is the project design coordinator and document quality control authority. Prime Consultant will review and verify deliverables prior to submission to Owner. Incomplete or lacking deliverables may be rejected. Owner will review complete deliverables for compliance and acceptance.

2. Planned Project Scope of Work:

The boiler room upgrade should consist of the following but not limited to:

- a. Replace existing boilers and associated equipment that is due for replacement.
 - b. Replace existing water heaters original to the building construction.
 - c. Replace failed wood beam and revise structural integrity of the boiler room roof.
 - d. Flooring covering to prevent leakage to the lower floor.

B. SCOPE OF CONSULTANT SERVICES

For the purpose of this document, the phrase “Consultant(s)” refers to the person, partnership, corporation, joint venture, or other business entity with which the District contracts to provide the professional services required for this project.

Anticipated Scope of Consultant Services: For this project, the Consultant shall provide all professional services necessary to support the successful completion of this project. The Consultant’s services shall include, but are not limited, to the following:

1. Consultant Design Phases/Deliverable Requirements: The following design phases with corresponding design deliverables shall be required for this project. See “Deliverables Checklist” (Appendix B, Attachment A Deliverable Checklist in Sample FPSA) and referenced District Design Guidelines for additional information on submittal requirements.
 - a. Schematic Design Phase Submittal (35%)
 - b. Design Development Phase Submittal (65%)
 - c. Construction Document Phase Submittal (95%)
 - d. Bid Documents Submittal (100%)

2. Phase 1 Design Development

- a. Develop Project Scope and Design; Prepare Construction Drawings and Specifications with cost estimates
 - i. Verification of the Planned Project Scope of Work: As part of the Schematic Design Phase work, the Consultant shall verify and update the Planned Project Scope of Work. Consider sequencing and phasing of the work around the school’s schedule, and provide recommendations. cursory review of the District’s hazmat documentation will be necessary to ensure the project is viable and will remain within budget. The Consultant shall consult with the District Project Manager for any deviation from the Planned Project Scope of Work prior to completing the Schematic Submittal. Schematic Submittal shall reflect the final approved project scope of work. Value engineering and innovative design solutions are encouraged.

- ii. Verification of the Construction Budget: The Consultant shall verify the project scope of work at each submittal with respect to required cost estimates at the 35%, 65%, and 95% submittal. Prior to all milestone submittals, the Consultant shall verify to the District Project Manager that the cost estimate was reviewed and is reflective of the design document submittal. Should the project cost estimate reflect a design (scope of work) that is over the District's budget (CCAP), the Consultant shall, at the direction of the District Project Manager, make changes to arrive at the optimum design and bidding strategy by one of the follow or combination of methods. In general, it is expected the Consultant shall develop appropriate project scope at, or slightly exceeding, the available construction budget.
 - a. Adjust the design (scope of work) and/or propose additive alternates in consultation with the District Project Manager at no additional cost to the District
 - b. Revise the cost estimate at no additional cost to the District
 - iii. Project Design Review: ASD milestone Project Design Reviews are organized by the ASD PM and executed using Bluebeam Revu (Bluebeam) sessions at Planning/15%, 35%, 65%, and 95% design phases. The use of Bluebeam allows for a collaborative, digital review for the Project; involving ASD Reviewers and Consultants, including the Consultant's cost estimator. ASD will provide all comments, written and noted, in the Bluebeam session and the Consultant shall assist the District by reviewing and responding in writing to all comments in the Bluebeam session; identifying and making written recommendations to the ASD Project Manager regarding the most critical design issues. The most critical path design issues will be summarized and discussed in a Post-Review Debrief (to be held at each design phase). The Project Manager will organize/invite Reviewers to the Post-Review Debrief. The Consultant shall act as the Meeting Facilitator of the Post-Review Debrief. The Post-Review Debrief is not meant to be a 'page-turn' review of design documents and comments, but a one-hour summarization of the most critical path items in design development and the team's intent/approach to resolve. Once the Post-Review Debrief is held, the PM will give Consultant notice to proceed to next design phase, pending any requested changes prior to NTP. The Project Manager will then verify that each comment and response has a Bluebeam **status** set and **finish** the Bluebeam session for ASD archives.
 - iv. Bidding and Permitting: The Consultant shall assist the District during the bidding and permit review of the project. During this phase of work, the Consultant's services shall include providing assistance during Municipality of Anchorage plan review and construction permit application process [utilizing MOA electronic plans review protocols], attendance at pre-bid conference and pre-bid site visits, answering bidder's questions, and assisting the District in preparing necessary bid addendum. Provide all signed and stamped bid documents electronically on writable CD-ROM (drawings should be submitted in most current version of AutoCAD used by the Anchorage School District or as determined by ASD Project Manager and PDF versions).
3. Phase 2 Construction Administration & Closeout
- a. Perform Construction Administration Services
 - i. The Consultant's services include attendance at the pre-construction conference and other scheduled meetings during construction.
 - ii. Review of submittals; respond to Requests for Information (RFIs), Potential Change Orders (PCOs), DCVRs, Information Bulletins, inspections, reviews of contractor pay requests, and review of closeout documentation.

Specifications and Scope of Services
Section IV

- iii. If part of the project, the consultant will participate in commissioning.
 - iv. Provide as-built Record Drawings and "Roof Section Schedule" (in Excel) electronically on CD-ROM. ASD will provide an Excel template for the "Roof Section Schedule". Provide both CAD and independent PDF files. Drawings shall be prepared using current ASD approved AutoCAD version and clearly identified as record drawings.
4. Anticipated Required Consultant Service Disciplines: Anticipated disciplines required for this project shall include, but are not limited to:
- a. Architectural
 - b. Structural Engineering
 - c. Mechanical Engineering
 - d. Electrical Engineering
 - e. HAZMAT Consultant
 - f. Cost Estimating
5. Additional Requirements:
- a. Reference Record Drawings: The Consultant shall research the District Plans Room records to identify important record drawings that may be issued with the Bid Documents as Reference Record Drawings or made available for viewing by the bidders at the District Plans Room. The Reference Record Drawings are intended to provide sufficient information to allow bidders to ascertain the physical conditions of the building including types of construction, building dimensions, etc. The Consultant shall prepare a Reference Record Drawing Cover Memo describing the reference record drawings. The cover memo shall include historical building and project information. If applicable, the Reference Record Drawing Cover Memo and the Reference Record Drawings shall be issued as part of the Bid Documents.
 - b. Use of the Anchorage School District Design Guidelines: Unless otherwise directed, the Consultant's designs and submittals shall conform to the requirements of the Anchorage School District Design Guidelines. The Consultant is advised the Anchorage School District Design Guidelines will be periodically updated. The Consultant's services and design shall conform to revisions to the Design Guidelines as they occur throughout the project.
 - c. Use of the Anchorage School District Guide Specifications: Unless otherwise directed, the Consultant shall utilize the Anchorage School District Guide Specifications as the basis for the technical specifications for this project. The Consultant is advised the Anchorage School District Guide Specifications will be periodically updated. The Consultant's services and design shall conform to revisions to the Guide Specifications as they occur throughout the project.
 - d. Services related to Construction Submittals: For this project, the District will develop a Submittal Register and a Submittal Status Log based on the developed project specifications. The applicable specification section shall be based on a guide specification section to be provided by the District. During construction, the Consultant shall be responsible for communications, the management of the Construction submittals, Requests for Information, construction record documents and photographs, and other purposes as directed by the Project Manager for the District utilizing owner-provided construction management software, currently Procore Construction Management. The

Consultant shall receive the submittals directly from the Construction Contractor. Upon completion of the review of the submittals, one copy of the submittal shall be retained by the Consultant. The Consultant shall return the remaining copies of the submittals directly to the Construction Contractor.

- e. **Extended District Review:** The Consultant shall acknowledge that while review periods are scheduled during the design process, the District plan review resources may not be able to accommodate the schedule due to work load. In some cases, follow-up comments beyond the scheduled review period may be necessary. The Consultant is encouraged to be proactive in assisting the District in facilitating the design review process.
- f. **Use of Standard Anchorage School District Invoice Format:** The Consultant shall utilize a standardized Anchorage School District Invoice Format. The format will be provided by the District to the consultants.
- g. **Technical Specifications Format:** The Consultant shall utilize formatting standards for documenting technical specifications. The District will provide the standards format to the consultants.
- h. **MOA Building Safety Pre-Application Meeting:** At a minimum, one design pre-application meeting with the Municipality Building Safety officials at 35% schematic design is required. The following disciplines are suggested to attend: architectural, structural, mechanical, electrical, fire, traffic and zoning. Designer has responsibility to determine final list of disciplines required based on scope of project.

C. PROJECT SCHEDULE

Based on the Tentative Project Schedule and Specific Project Schedule Requirements below, the Offeror shall develop a preliminary project schedule covering the period from Notice to Proceed (NTP) through Design Completion based on anticipated workload and resources and include it as part of the Offeror’s proposal response to Part B, Article 2 Methods. Identify all submittal milestones including submittal dates, cost estimate submittal dates, and District review comments periods.

1. Tentative Project Schedule for Design Work:

Requirement	Anticipated Dates
RFP/Consultant Selection/Negotiation:	January – March 2024
Anticipated Contract Award/NTP:	April 2024
35%, 65%, 95% Documents:	April – June 2024
Final Construction Documents:	July 2024
Bid Period:	August – September 2024
Anticipated Construction Period:	April 2025 – September 2025
Record Documents:	December 2025

2. Specific Project Schedule Requirements:

- a. Allow 2 weeks after each submittal for review by the District.

D. INFORMATION TO BE PROVIDED BY THE DISTRICT

The following information is available for review and use by the consultants during design:

- 1. Gruening Middle School, 9601 Lee St., Eagle River, AK 99577

Specifications and Scope of Services
Section IV

2. Historical As-Built/Project Documents/AHERA Documents – Existing documents are available at the District Capital Planning & Construction Department. Proposers can view existing documents by coordination with the project support section for access to the plans room. Proposer must coordinate a time in advance with Capital Planning & Construction (CP&C) project support staff at 907-348-5215.

E. ADDITIONAL INFORMATION

1. Attachment D Gruening Middle School Floor Plan.
2. Attachment E Gruening Middle School Mechanical Upgrades report dated December 7, 2023.
3. Attachment F Gruening Middle School Boiler Room Beam Replacement & Upgrades Structural Calculations and Final Drawing Dated November 27, 2023.
4. Attachment G Gruening Middle School Photos of shoring and existing conditions.

END OF SECTION IV

THIS FORM MUST BE RETURNED WITH THE OFFEROR'S PROPOSAL

Addendum Number(s)/Date(s) _____ is/are hereby acknowledged.

REPRESENTATION. THE OFFEROR REPRESENTS THAT IT IS, IS NOT A MINORITY BUSINESS ENTERPRISE;

AND/OR

REPRESENTATION. THE OFFEROR REPRESENTS THAT IT IS, IS NOT A WOMEN BUSINESS ENTERPRISE;

AND/OR

REPRESENTATION. THE OFFEROR REPRESENTS THAT IT IS, IS NOT A LABOR SURPLUS AREA FIRM.

FIRM'S NAME: _____

MAILING ADDRESS: _____

CITY/STATE/ZIP: _____

PHYSICAL BUSINESS ADDRESS: _____

CITY/STATE/ZIP: _____

CONTACT PERSON FOR THIS SOLICITATION: _____

FAX NO.: _____

TELEPHONE NO.: _____

CELL PHONE NO.: _____

ALASKA BUSINESS LICENSE NO.: _____

FEDERAL TAX ID NO.: _____

EMAIL ADDRESS: _____

CERTIFICATION

I certify that I am a duly authorized representative of the firm listed above and that the information and materials enclosed with this proposal accurately represent the capabilities of the firm to provide the services indicated in compliance with the requirements of the solicitation. I certify that no member of the School Board or District employee, or spouse or other member of his/her household, has or shall have any undisclosed interest in the firm or this proposal, as provided in the Instructions to Offerors ("Conflicts of Interest"). The School District is hereby authorized to request from any individual any pertinent information deemed necessary to verify information regarding the capacity of the firm and for purposes of determining responsiveness of the proposal or responsibility of the firm as a prospective contractor. In compliance with the solicitation, the offeror agrees, if this offer is accepted within 90 calendar days from the date specified in the solicitation for receipt offers, to furnish any or all items on which prices are offered at the price set opposite each item, delivered at the designated places, within the times specified in the solicitation.

SIGNATURE: _____

PRINTED NAME AND TITLE: _____

DATE: _____

CONFIDENTIAL WHEN COMPLETED

Evaluation of this statement may preclude the necessity for a comprehensive on-site audit of the Contractor's records. Entries may be handwritten, if legible.

1. Identify your fiscal year, including beginning and end dates _____
2. List your actual costs, by the following categories, for your most recent fiscal year. Cost terminology is attached.
 - a. Direct Labor \$ _____
 - b. Attach a Trial Balance with grouping of accounts used to arrive at the following Indirect Cost amounts:

Fringe Benefits	\$ _____
General & Administrative Expenses	\$ _____
Sum	\$ _____
 - c. Indirect Cost Rate (Sum of b/a) _____ %
3. If your records have been audited with the last 2 years by a governmental agency, attach a copy of the Audit Report.
4. Attach copies of your most recent Internal and Audited Financial Statements.
5. Are your accounting methods for recording contract costs based on a job or project identified cost system?
 Yes No If your response is "No", attach an explanation of your cost accounting system
6. If you charge your projects based on unit rates (e.g. for computer time, laboratory tests, copies or equipment use, etc.) attach a list of such items and unit prices.
7. Do you offset revenue received from unit rate payments against the applicable Indirect Cost Accounts?
 Yes No

CERTIFICATION

I certify that I am a duly authorized representative of the Contractor and that information and materials enclosed within this statement accurately represent financial records of the company.

Signature _____	Date _____
Name and Title _____	Telephone No. _____
Company Name _____	Fax No. _____
Address _____	Email Address: _____

ANCHORAGE SCHOOL DISTRICT

FORMAL PROFESSIONAL SERVICES AGREEMENT

Contract No.:	_____
Requisition No.:	_____
RFP No.:	_____
Board Memo No.:	_____

PROJECT TITLE: _____

This contract consists of the following, which are hereby incorporated by reference as if in full text; consisting of the following documents in order of precedence:

1. Formal Professional Services Agreement – (Consisting of XX-Pages):
2. RFP XXXX-XXX, and associated addenda
3. Contractor's proposal dated XX
4. Contractor's negotiated Cost Proposal dated XX
5. Contractor's Fee Rate Schedule dated XX

This agreement is between the Anchorage School District and designer (hereafter "Contractor"), effective on the last date executed by its parties.

CONTRACTOR

SIGNATURE: _____ Date _____
NAME: _____
TITLE: _____

DISTRICT

SIGNATURE: _____ Date _____
NAME: David Whiting
TITLE: Senior Director, Purchasing/Warehouse

In consideration of the terms, conditions and promises of Articles 1 through 6 in this document, the parties hereto agree:

ARTICLE 1 PURPOSE

1.1 The purpose of this agreement is to provide professional design services.

Insert Information

Project Name
Project Number **Insert Number**
RFP Number **Insert Number**
Revised 4-18-18

**ARTICLE 2
COMPENSATION**

2.1 The maximum amount payable under this agreement (see Appendix C) shall not exceed:

\$ _____ Account Code(s): _____

**ARTICLE 3
PERIOD OF PERFORMANCE**

3.1 Contractor shall commence work under this agreement as authorized by written notice(s) to proceed at each phase and shall complete the work in accordance with any time schedule required by Appendix F. This agreement is of no force or effect until executed by the Contractor and the District and no services shall be undertaken or performed until a Notice to Proceed (NTP) is issued.

3.2 The period of performance under this agreement shall end upon the date of the District's final acceptance of the Project, or approval of the Contractor's final invoice pursuant to the Contractor's satisfactory completion of obligations under this Agreement, whichever is later.

**ARTICLE 4
APPENDICES**

4.1 The following appendices are attached to this document and incorporated herein by reference:

<u>Appendix</u>	<u>Title</u>
A	General Conditions
B	General Architectural/Engineering and Design & Construction Phase Services
Attachment A	Deliverables Checklist (Attachment A to Appendix B)
C	Basis of Compensation
D	Indemnification and Insurance (plus certificate of insurance)
E	Project Staffing and Subcontractors
F	Master Time Schedule

**ARTICLE 5
DISTRICT**

Project Manager
Name: _____

ASD Office: _____ Capital Planning & Construction

Street: _____ 1301 Labar St.

City, State, Zip: _____ Anchorage, Alaska, 99515

Fax No.: _____ (907) 348-5207

Office No.: _____

Cell No.: _____

Email Address: _____

**ARTICLE 6
CONTRACTOR**

Company Name: _____ AK Business License No.: _____

Principal Name: _____ Federal Identification No.: _____

Street: _____

P.O. Box: _____

City, State, Zip: _____

Fax No.: _____

Office No.: _____

Cell No.: _____

Email Address: _____

TYPE OF FIRM (Check One)	
Individual	<input type="checkbox"/>
Partnership	<input type="checkbox"/>
Joint Venture	<input type="checkbox"/>
Corporation	<input checked="" type="checkbox"/>
In State of: AK	

Project Name
Project Number Insert Number
RFP Number Insert Number
Revised 4-18-18

Contract No:
Date Prepared:

ANCHORAGE SCHOOL DISTRICT
FORMAL PROFESSIONAL SERVICES AGREEMENT

INDEX

<u>ARTICLE</u>	<u>TITLE</u>
A1	Definitions
A2	Information and Services from Others
A3	Occupational Safety and Health
A4	Equal Employment Opportunity
A5	Payments to the Contractor
A6	Changes to the Agreement
A7	Audits and Records
A8	Inspections by Anchorage School District
A9	Termination or Suspension
A10	Inducement/Conflict of Interest
A11	Covenant Against Contingent Fees
A12	Endorsement of Documents
A13	Ownership of Work Products
A14	Subcontractors, Successors and Assigns
A15	Claims
A16	Extent of Agreement
A17	Notices/Communications
A18	Taxes
A19	Governing Laws
A20	Force Majeure Suspension
A21	Waiver
A22	Interpretation
A23	Miscellaneous Provisions
A24	Additional Provisions

ARTICLE A1 Definitions

The following words and phrases where appearing with first letters capitalized in any appendix contained in this Agreement, shall have the following meanings:

- A1.1 **Additional Services.** Services performed by the Contractor which are beyond the Scope of Services required by this Agreement prior to any Amendment thereto.
- A1.2 **Agreement.** This professional services agreement which has been signed by both the Anchorage School District and the Contractor. The Agreement consists of the two-page contract document, including Articles 1 through 6 thereof, Appendices A through F which are incorporated therein by reference, and any Amendments thereto.
- A1.3 **Amendment.** A written change to the Agreement which modifies the Contractor's Scope of Services, conditions of service, time for performance, or compensation, or any combination of the foregoing. To be effective, an Amendment must be signed by both the Anchorage School District and the Contractor, and may require approval by the Anchorage School Board.

Project Name
Project Number **Insert Number**
RFP Number **Insert Number**
Revised 4-18-18

General Conditions
Appendix A

- A1.4 Anchorage School District/ASD/District. The designated managing agency of the Municipality of Anchorage (the owner of the Project), which is authorized to manage the school facility that is the subject of this Agreement. The term "Anchorage School District" includes all school board members, officers, employees, representatives, and agents of the Anchorage School District.
- A1.5 Basic Services. Services performed by the Contractor which are within the Scope of Services required by this Agreement prior to any Amendment thereto.
- A1.6 Bid Documents. The Construction Contract Documents, plus the instructions to bidders and bid forms.
- A1.7 Claim. A request by the Contractor for additional compensation or time extension which has not or cannot be resolved through the usual Amendment procedure because the validity of the request is disputed by the Project Manager or the Anchorage School District.
- A1.8 Commissioning. A methodical process intended to ensure that building systems perform in conformance with the intent for which they were designed. Such systems can include, but are not limited to: heating, ventilating, air conditioning, fire protection, electrical, security, data, communications, and control.
- A1.9 Conformed Documents. Construction drawings and specifications revised to reflect changes issued by addenda prior to bid opening.
- A1.10 Construction Contract. The contract between the Anchorage School District and the Construction Contractor for the construction of all or part of the Project, including, without limitation, the providing of labor, materials, and equipment to be incorporated into the Project, and including all change orders thereto. The Anchorage School District, in its discretion, may award more than one Construction Contract in relation to the Project.
- A1.11 Construction Contract Award Price (CCAP). The amount budgeted by the Anchorage School District to cover the costs of construction of the Project. The CCAP includes the cost of all Construction Contracts required for the completion of the construction of the Project. The CCAP does not include the compensation of the Contractor or the cost of the land, site investigations, right-of-ways, furnishings and equipment, special inspections, agency plan review permit fees, or Anchorage School District administrative costs, all of which are the responsibility of the Anchorage School District unless otherwise stated herein.
- A1.12 Construction Contract Documents. The Construction Contract form(s), general and supplementary conditions, general requirements, technical drawings and specifications for the Project, and any addenda thereto.
- A1.13 Construction Contractor. The person, partnership, corporation, joint venture, or other type of business entity with which the Anchorage School District contracts in the Construction Contract to construct all or part of the Project.
- A1.14 Contractor. The person, partnership, corporation, joint venture, or other type of business entity with which the Anchorage School District contracts to provide the professional services required by this Agreement. The term "Contractor" includes all officers, directors, employees, partners, joint venturers, consultants, Subcontractors, representatives, and agents of the Contractor.
- A1.15 Days. Calendar days.
- A1.16 Deliverable. A service product created by the Contractor and deliverable to the Anchorage School District under requirements of the Agreement.

- A1.17 Design Adjustment. A modification to the Educational Specifications, CCAP, management plan, Master Schedule (Appendix F hereto), or previously approved design documents, which modification has no impact on the Contractor's time for performance or the compensation due the Contractor as provided by this Agreement. A Design Adjustment shall be made in writing by the Project Manager, the Anchorage School District, or the Anchorage School Board.
- A1.18 Designer of Record. The Contractor and its subcontracted business entities who are professionally responsible for the Work Products produced under this Agreement.
- A1.19 Educational Specifications. The detailed written summary of the requirements for the facility to which the Project relates, which sets forth the Anchorage School District's overall program and design objectives, constraints and criteria, including space requirements and relationships, quality levels, flexibility and expandability, special equipment and systems, and site requirements.
- A1.20 Estimated Total Construction Cost. The Contractor's current estimated cost for all construction Work necessary to complete the Project in accordance with the Construction Contract Documents. The Estimated Total Construction Cost does not include the cost of land acquisition, site investigation, design, public artwork, Anchorage School District administration, or any furnishings and equipment, special inspections, permit fees, which is not included in the Construction Contract. The CCAP and the Estimated Total Construction Cost may not be the same amount.
- A1.21 Information Bulletin. Written conveyance of information pertinent to the Project initiated by the Contractor or Anchorage School District and issued to the Construction Contractor.
- A1.22 Master Time Schedule. A project-specific calendar indicating: Contractor's identified services and Work elements; their start, duration and end dates; their critical milestones (including action required by Anchorage School District and bid dates); and Deliverables.
- A1.23 Notice to Proceed (NTP). Written authorization from the Project Manager to the Contractor to provide all, or specified portions of, the services required by this Agreement.
- A1.24 Project. The school facility, or the portion of the school facility, which is to be designed by the Contractor in accordance with this Agreement and constructed by the Construction Contractor in accordance with the Construction Contract.
- A1.25 Project Manager. The Anchorage School District's employee who has the direct responsibility for the Project. The Project Manager is the Anchorage School District's project representative and the Contractor's primary point of contact with the Anchorage School District.
- A1.26 Record Drawings. Graphic representations of the executed Work prepared, in part, by the Construction Contractor from Conformed Documents to show significant changes in the Work made during the construction process and transferred to drawing media by the Contractor.
- A1.27 Request for Information (RFI). Written request from the Construction Contractor to the Anchorage School District requesting information related to construction of the Project.
- A1.28 Scope of Work/Scope of Services. The work to be performed under a contract, typically divided by tasks with noted deliverables and deadlines.
- A1.29 Subcontract. An agreement between the Contractor and a Subcontractor by which the Subcontractor agrees to provide to the Anchorage School District a portion of the services required of the Contractor under the terms of this Agreement.

General Conditions
Appendix A

- A1.30 Subcontractor. A person, partnership, corporation, joint venture, or other business entity with which the Contractor subcontracts to provide a portion of the services required of the Contractor under the terms of this Agreement.
- A1.31 Technical Specifications and Design Standards. Guidelines established by the Anchorage School District to define performance quality of design elements, construction materials, systems and installations for application to facilities under Anchorage School District operational control. Such guidelines are working documents published periodically in the form of two separate documents: Design Standards and Technical Specifications.
- A1.32 Work. All labor and materials provided by the Construction Contractor to construct the Project in accordance with the terms of the Construction Contract.
- A1.33 Work Product. Without limitation, all documents, models, renderings, and other materials to be furnished by the Contractor to the Anchorage School District by or on behalf of the Contractor, or by any consultants, subcontractors, or others retained by the Contractor (hereafter "Subcontractors"), and all written information, reports, studies, object or source codes, flow charts, diagrams, specifications, and other tangible material which have been created by the Contractor in order to provide services pursuant to this Agreement.

ARTICLE A2 Information and Services from Others

- A2.1 The Anchorage School District may, at its election or in response to a request from the Contractor, furnish information or services from other contractors. Contractor shall review such information and services for adequacy. If, in the Contractor's opinion, such information or services is inadequate, the Contractor must notify the Project Manager of the specific service or material deemed inadequate and the extent of the inadequacy prior to use in the performance of this Agreement. The Project Manager will then evaluate and resolve the matter in writing. Unless so notified by the Contractor, the Anchorage School District may assume the information or services provided are adequate.

ARTICLE A3 Occupational Safety and Health

- A3.1 The Contractor and its Subcontractors shall observe and comply with (a) the Federal Occupational Safety and Health Act of 1970 and all regulations and standards promulgated thereunder, and (b) all State of Alaska occupational safety and health laws and regulations. The Contractor shall include a provision in each Subcontract requiring the Subcontractor to observe and comply with said laws and regulations.

ARTICLE A4 Equal Employment Opportunity

- A4.1 The Contractor certifies that it will not discriminate against any employee or applicant for employment because of race, color, religion, national origin, ancestry, age, sex, marital status, mental or physical handicap, or change in marital status, in employment, provision of services or otherwise. The Contractor shall take affirmative action to ensure such non-discrimination, including but not limited to the following: employment, upgrading, demotion, transfer, recruitment or recruitment advertising, layoff or termination, rates of pay or other forms of compensation, and selection for training including apprenticeship. The Contractor shall post in conspicuous places, available to employees and applicants for employment, notices setting forth the provisions of this nondiscrimination clause.
- A4.2 The Contractor shall state, in all solicitations or advertisements for employees to Work in the performance of this Agreement, that all qualified applicants will receive consideration for

employment without regard to race, color, religion, national origin, ancestry, age, sex, marital status, mental or physical handicap, or change in marital status.

- A4.3 The Contractor shall comply with the requirements of the Anchorage Municipal Code, Chapter 7.50.010-.120, as well as any procedures adopted by the Anchorage School District to implement the policies set forth therein.
- A4.4 The Contractor shall comply with any and all of the following laws and directives, and any regulations promulgated thereunder, which may be applicable to the Project or this Agreement, all of which are incorporated herein by reference:
- Title IV of the Federal Civil Rights Act of 1964;
 - Federal Executive Order 11625 (Equal Employment Opportunity);
 - Title 41, Code of Federal Regulations, Part 60 (Equal Employment Opportunity);
 - Title 49, Code of Federal Regulations, Part 21 (Discrimination);
 - Title 49, Code of Federal Regulations, Part 23 (Minority Business Enterprises);
 - Office of Management and Budget (OMB) Circular 102, Attachment O (Procurement Standards);
 - Alaska Statute (AS) 18.80.200-300 (Discrimination).
- A4.5 The Contractor shall include the provisions of this Article in every Subcontract and purchase order, and shall require each Subcontractor to include these provisions in every sub-subcontract, so that these provisions will be binding upon each Subcontractor, sub-subcontractor and vendor providing services or goods to the Project.

ARTICLE A5 **Payments to the Contractor**

- A5.1 Payments shall be based on Contractor's invoices which have been submitted in accordance with this Article and the provisions of Appendix C hereto, and which have been approved by the Anchorage School District. The sum of all payments shall not exceed the maximum allowable amount of compensation stated in Appendix C, or any Amendment thereto. All invoices shall be in a format provided by the Anchorage School District.
- A5.2 The Anchorage School District will attempt with due diligence to obtain any approval of Contractor's invoices or payment to Contractor which may be required of a funding agency and to issue Notice(s) to Proceed in a timely manner. The Contractor shall not perform any services without a Notice to Proceed. The Contractor shall not be entitled to payment for services performed or any associated reimbursable costs incurred which are outside the Scope of Services and costs authorized by Appendix C, or any Amendment thereto.
- A5.3 In the event that items on an invoice are disputed by the Anchorage School District, payment for those items will be withheld until the dispute is resolved. Payment for undisputed items will not be withheld, subject to the Anchorage School District's right of set-off or counterclaim.
- A5.4 The Contractor shall submit a final invoice and all other documentation required by this Agreement to the Project Manager within ninety (90) Days after the final acceptance of services by the Anchorage School District. The Contractor is not entitled to payment of any invoice submitted after said ninety (90) Day period, unless the Anchorage School District has given prior written consent thereto.

Project Name
Project Number **Insert Number**
RFP Number **Insert Number**
Revised 4-18-18

General Conditions
Appendix A

- A5.5 All payments due the Contractor will be made within thirty (30) Days of the Project Manager's approval of the invoice.

ARTICLE A6 Changes to the Agreement

A6.1 Changes in the Contractor's compensation may be made only by written Amendment, signed by both parties and, if required, approved by the Anchorage School Board. If a change is made in the Contractor's Scope of Services or conditions of service under this Agreement, and such change results in an increase or decrease in the Contractor's costs, an equitable adjustment to the Contractor's compensation shall be made and set forth in an Amendment. The Contractor shall not perform any Additional Services prior to receiving a Notice to Proceed, except as the Contractor may be requested under the provisions of Article A15 (Claims).

A6.1.1 From time to time throughout the course of Contractor's performance of this Agreement, the Project Manager may request the Contractor to make one or more Design Adjustments in relation to the Project. The making of any Design Adjustment is part of Basic Services and shall not entitle the Contractor to an Amendment. Neither the Contractor's time for performance nor the Contractor's compensation will be adjusted in relation to a Design Adjustment.

A6.2 Changes in the Contractor's time for performance, including any change in the period of performance stated in the Agreement or in the Master Time Schedule which is to be incorporated into this Agreement as an appendix, may be made only as follows: (a) If the change in the time for performance is associated with a change in the Contractor's compensation, the change must be made by the same Amendment which changes the Contractor's compensation, or (b) if the change in time for performance is not associated with a change in the Contractor's compensation, then such change may be set forth in a new Master Time Schedule appendix which is signed and dated by the parties, and then substituted for the original Master Time Schedule appendix, or its most recent substitute.

A6.3 The Contractor shall submit a written request for an Amendment to the Project Manager within thirty (30) Days after the beginning of the occurrence of any act or event of which Contractor becomes aware, or should have become aware, and in relation to which Contractor believes it is entitled to additional compensation and any associated time extension. Such acts or events may include but are not limited to the Anchorage School District requesting, either verbally or in writing, that the Contractor perform Additional Services which are not already covered by a fully executed Amendment. If the Project Manager deems an Amendment appropriate, he will negotiate the terms of an Amendment with the Contractor. Unless such written request for an Amendment is submitted in a timely manner, the Contractor shall be deemed to have acknowledged that the act or event does not entitle it to additional compensation or a time extension.

A6.4 The Contractor shall submit any request for modification of the Master Time Schedule to the Project Manager within a reasonable period of time after the beginning of the occurrence or event giving rise to the request for such modification.

ARTICLE A7 Audits and Records

A7.1 The Contractor shall maintain records and keep in safe condition all documents relating to performance, communications, correspondence and costs pertinent to this Agreement. The Anchorage School District's authorized representatives shall have the right to examine such records and documents, and Contractor's accounting procedures and practices.

A7.2 The Anchorage School District's authorized representatives shall have the right to examine all accounting books, records, data and other documents of both the Contractor and Contractor's first tier Subcontractors related to the negotiation, pricing and performance of this Agreement,

and any Amendment thereto, for the purpose of evaluating the accuracy, completeness and currency of the information submitted as part of or in relation to any invoice. Such right of examination shall extend to all documents necessary to permit the Anchorage School District to evaluate the information, computations and projections used to the extent deemed necessary by the Anchorage School District, in its sole discretion.

A7.3 The materials described in this Article shall be made available at the business office of the Contractor at all reasonable times for inspection, audit or duplication, for a minimum of seven (7) years from the date of final payment under this Agreement and for such longer period, if any, as may be required by an applicable statute.

A7.3.1 If this Agreement is completely or partially terminated, records relating to the services terminated shall be made available for a minimum of seven (7) years from the date of any resulting final settlement.

A7.4 If the Agreement is funded to any extent with federal or state monies, or both, the appropriate federal or state authorities may also examine the accounting books, records, data and the other documents of the Contractor and Contractor's first tier Subcontractors.

A7.5 The Contractor shall include the provisions of this Article in all first tier Subcontracts so as to be binding on all first tier Subcontractors.

A7.6 All documents which relate to an appeal under Article A15 (Claims), litigation or the settlement of a Claim arising out of the performance of this Agreement shall be made available to the Anchorage School District for inspection and copying until such appeal, litigation or Claim has been finally concluded. Such documents shall be made available to the Anchorage School District within thirty (30) Days of the Anchorage School District's request therefor.

ARTICLE A8 Inspections by Anchorage School District

A8.1 The Anchorage School District shall have the right to inspect, in the manner and at reasonable times it considers appropriate during the period of this Agreement, all facilities and activities of the Contractor as may be engaged in the performance of this Agreement.

ARTICLE A9 Termination or Suspension

A9.1 This Agreement may be terminated by either party upon ten (10) Days' written notice if the other party (a) fails substantially to perform in accordance with the terms of the Agreement through no fault of the party initiating the termination, and (b) fails to cure such failure to perform before the end of the ten-Day notice period, or if the cure cannot be completed within a ten (10) Day period, fails to take substantial steps toward effecting such cure. If the Anchorage School District terminates this Agreement because of Contractor's default (default termination), the Anchorage School District will not make any payment to Contractor beyond those payments already made, until after completion of the Project and after deduction of any damages which are incurred by the Anchorage School District as a result of the Contractor's default, or which are allowable as a set-off, or as the result of a counterclaim, cross-claim or cause of action. In no event shall Contractor be entitled to payment for the following: (a) unperformed services; (b) services which cannot be substantiated in whole or in part by the Contractor to the satisfaction of the Anchorage School District in its sole discretion; (c) services or Work Products which are unsatisfactory to the Anchorage School District in its sole discretion and are the result of Contractor's failure to perform in accordance with the terms of the Agreement; (d) direct non-salary costs which are incurred after Contractor's receipt of the notice of termination, or (e) markup for anticipated profit or indirect costs relating to unperformed services.

Project Name
Project Number **Insert Number**
RFP Number **Insert Number**
Revised 4-18-18

General Conditions
Appendix A

- A9.1.1 If the Anchorage School District terminates this Agreement because of Contractor's default, the Anchorage School District may assume responsibility for the services to be provided hereunder and prosecute the same to completion by contract or otherwise, and the Contractor shall be liable to the Anchorage School District for any cost incurred by the Anchorage School District which exceeds the cost the Anchorage School District would have incurred had the Contractor fulfilled its obligations under the Agreement. Settlement of liability for such excess costs or for any delay in completion of the services required under this Agreement or construction of the Project which arises out of Contractor's default may constitute the basis of a set-off, counterclaim, cross-claim, or cause of action available to the Anchorage School District.
- A9.2 The Anchorage School District may at any time terminate (convenience termination) or suspend this Agreement for its needs or convenience upon ten (10) Days' written notice to the Contractor. In the event of a convenience termination or a suspension of the Agreement for more than three (3) months, the Anchorage School District will compensate the Contractor for services performed and any expenditures incurred prior to the effective date of the written notice of termination or suspension. No fee, profit or other compensation for the uncompleted portion of the services will be paid, except for already incurred indirect costs which the Contractor can establish and for which the Anchorage School District would have compensated the Contractor over the life of this Agreement, but because of the termination or suspension would have to be absorbed by the Contractor without further compensation.
- A9.3 If federal funds support this Agreement, settlement for default or convenience termination must be approved by the funding agency and shall conform with Title 41, Code of Federal Regulations, Subparts 1-8.604 or 1-8.203 and 1-8.213.
- A9.4 In the event of termination or suspension of the Agreement for over three (3) months, the Contractor and its Subcontractors shall discontinue all services, or such portions of service as directed in the notice, and deliver to the Project Manager all Work Products, including all data, reproducibles, plans, specifications, reports, estimates, summaries, schedules, and other documents and data prepared or in the process of being prepared pursuant to this Agreement.
- A9.5 The Contractor shall include the provisions of this Article in each Subcontract so as to be binding on each Subcontractor.
- A9.6 The rights and remedies of the Anchorage School District as set forth in this Article A9 are not exclusive, and are in addition to any other rights and remedies the Anchorage School District may have at law or as provided elsewhere in this Agreement.
- A9.7 Unless earlier terminated as provided in this Article, this Agreement shall remain in force for a period which may reasonably be required for the Basic Services and Additional Services hereunder. However, the provisions of the Agreement relating to professional responsibility, dispute resolution, professional liability coverage, indemnification, governing law, records and ownership of documents shall remain in effect after termination of the other provisions of the Agreement.
- A9.8 The payment of any sums by the Anchorage School District under this Article A9 shall not constitute a waiver of any Claims for damages by the Anchorage School District against the Contractor.

ARTICLE A10 Inducement/Conflict of Interest

- A10.1 The Contractor agrees that it will not engage on a full-time or part-time basis, during the period of this Agreement, any person or persons who are or have been employed by the Anchorage School District during the period of this Agreement or during the ninety (90) Days immediately

preceding the date of this Agreement, except such employee(s) who have been regularly retired or approved in writing by the Anchorage School District.

ARTICLE A11 Covenant Against Contingent Fees

- A11.1 The Contractor shall comply with the Copeland "Anti-Kickback" Act (19 USC 874), and the U.S. Department of Labor Regulations promulgated thereunder (29 CFR, Part 3), both of which are incorporated herein by reference.
- A11.2 The Contractor warrants that it has not employed or retained any organization or person, other than a bona fide employee, to solicit or secure this Agreement and that it has not paid or agreed to pay any organization or person, other than a bona fide employee, any fee, commission, percentage, brokerage fee, gift or other consideration contingent upon or resulting from the award or making of this Agreement. For breach or violation of this warranty, the Anchorage School District has the right to void this Agreement without liability or, in its discretion, to deduct from the allowable compensation the full amount of such commission, percentage, brokerage or contingent fee.

ARTICLE A12 Endorsement of Documents

- A12.1 Endorsements (signatures) and professional seals, if applicable, must be included on all final drawings, specifications, and geotechnical reports prepared by the Contractor.

ARTICLE A13 Ownership of Work Products

- A13.1 Ownership of Work Products produced under this Agreement, including items which have pre-existing copyrights, shall remain with the Contractor. The Anchorage School District shall have an unrestricted, irrevocable license to use the Work Products without infringing any copyrights, and without additional compensation to the Contractor.
- A13.1.1 Unrestricted use shall include use: (1) for any additions, alterations, or other subsequent Work to the Project; (2) to demonstrate or reference conceptual arrangements, in whole or in part, for incorporation into any District project; and (3) reuse of a prototypical design on an Anchorage School District project.
- A13.2 Should the Anchorage School District elect to reuse Work Products produced by the Contractor and its Subcontractors under this Agreement and owned by the Contractor on any other project, the Anchorage School District shall indemnify, hold harmless and defend the Contractor and its Subcontractors against any damages or liabilities arising from such reuse.
- A13.2.1 When Work Products produced by the Contractor and its Subcontractors under this Agreement are reused by the Anchorage School District, the Contractor's and Subcontractors' signatures, professional seals and dates shall be removed. Such Work Products, which require professional signature and seal, will be signed, sealed and dated by the professional who is in direct supervisory control and responsible for the new project for which such Work Products are being reused.
- A13.3 The Contractor shall include this provision in every Subcontract so as to be binding on every Subcontractor.

ARTICLE A14 Subcontractors, Successors and Assigns

Project Name
Project Number **Insert Number**
RFP Number **Insert Number**
Revised 4-18-18

General Conditions
Appendix A

- A14.1 The Contractor shall provide to the Project Manager a list of all consultant firms with which the Contractor proposes to Subcontract, consistent with the District's qualifications-based Request for Proposals requirements, in order to provide a portion of the services required of the Contractor under this Agreement. The Contractor shall acquire the Project Manager's non-objection to any proposed Subcontractor prior to entering into a Subcontract. Upon request by the Project Manager, the Contractor shall provide additional information concerning the qualifications of any proposed Subcontractor.
- A14.2 If Appendix E identifies a named individual in the employ of Contractor, or a named Subcontractor, or a named individual in the employ of a Subcontractor, or any combination of the foregoing, as providing professional services under this Agreement, then Contractor shall employ such individual or subcontract with such Subcontractor so that the named individual(s) or Subcontractor, or both, shall provide the designated services. Contractor shall immediately notify the Project Manager in writing of a proposed replacement of named individual(s) or Subcontractor, or both. The Anchorage School District reserves the right to object to the proposed replacement so named in accordance with Section A14.1.
- A14.3 The Contractor shall not assign, delegate or transfer the whole or any part of this Agreement or any monies due or to become due hereunder, without the prior written consent of the Anchorage School District. Any assignment, delegation or transfer not in accordance with this provision shall be null and void and of no force or effect. This Agreement shall otherwise be binding upon and inure to the benefit of the successors and permitted assigns and delegates of the parties hereto.
- A14.4 The Contractor binds itself, its partners, officers, directors, Subcontractors, executors, administrators, successors, assigns, and legal representatives to this Agreement and to the successors, assigns and legal representatives of the Anchorage School District with respect to all covenants of this Agreement. The Contractor's Agreement is incorporated by this reference herein in all subsequent contracts with Subcontractors and their Subcontractors. This language shall be made a part of all contracts between the Contractor and its Subcontractors.
- A14.5 No payment, gratuity or offer of employment shall be made in connection with any Subcontract, by or on behalf of any Subcontractor to the Contractor, or by a sub-subcontractor to a higher tier subcontractor or any person associated therewith, as an inducement for the award of a Subcontract.
- A14.6 The Contractor shall include provisions appropriate to effectuate the purposes of this Agreement in all sub-tier agreements. Where Contractor is required to perform certain services in this Agreement, and the parties agree that all or a portion of those services are to be performed by a Subcontractor, the Contractor shall require the Subcontractor in the Subcontract to perform those services for the benefit of the Anchorage School District. Nothing stated herein, however, shall relieve the Contractor of the responsibility of performing all of its responsibilities and obligations under this Agreement.

ARTICLE A15 Claims

- A15.1 The Contractor shall notify the Project Manager in writing of the occurrence of any act or event of which Contractor becomes aware, or reasonably should have become aware, which may form the basis of a Claim within ten (10) Days of the occurrence of such act or event. If the matter cannot be resolved within seven (7) Days following the Project Manager's receipt of notification regarding the potential Claim, the Contractor shall, within the next fourteen (14) Days, submit a written "Notice of Claim" to the Project Manager in accordance with provision A15.1.2. The Anchorage School District will review and decide the Claim in accordance with provisions A15.1.3 through A15.1.6.

- A15.1.1 If directed by the Project Manager, the Contractor shall proceed with the performance of this Agreement, including the performance of any disputed services, pending final resolution of any Claim or action arising under the Agreement.
- A15.1.2 In any Notice of Claim, the Contractor shall set forth the following: (a) the provisions of the Agreement which apply to the Claim and under which the Claim is made, and (b) the specific relief requested, including any additional compensation claimed and the basis upon which it was calculated, and any additional time requested and the basis upon which it was calculated.
- A15.1.3 In relation to a Notice of Claim in an amount of \$25,000 or less, the Anchorage School District shall, if requested in writing by the Contractor, proceed with due diligence to attempt to issue a decision regarding the Claim within fifteen (15) Days of receipt of such a request. In relation to a Notice of Claim in an amount over \$25,000, the Anchorage School District shall proceed with due diligence to attempt to issue a decision regarding the Claim; in any event if the Claim is not decided within a thirty (30) Day period, the Anchorage School District shall notify the Contractor of the date by when the decision will be made.
- A15.1.4 In reviewing a Claim, the Anchorage School District may schedule a review hearing or request additional information from the Contractor in order to evaluate the Claim fully. The Contractor shall provide any additional information requested by the Anchorage School District within fifteen (15) Days of the receipt of the request for additional information. Failure by the Contractor to furnish such additional information shall constitute a waiver of the Claim.
- A15.1.5 The Anchorage School District will deliver to the Contractor a final written decision regarding a Claim. Any Amendment arising out of a Claim shall be subject to the provisions of Article A6 (Changes to the Agreement) herein.
- A15.1.6 If a Claim is not resolved in accordance with the procedures set forth in provisions A15.1.1 through A15.1.6 herein, the Contractor has no right to file an action against the Anchorage School District in a court of law, until the Claim is first subjected to non-binding mediation before a single mediator agreed upon by the parties. Such mediation shall be attended by a representative of the Contractor and a representative of the Anchorage School District, each of which has authority to enter into a full and final, binding settlement of the Claim, except where the final, binding settlement is subject to the Anchorage School District School Board's approval. Unless otherwise agreed in writing, all unresolved Claims of the Contractor shall be considered during a single mediation which shall occur prior to final payment by the Anchorage School District. The Anchorage School District and the Contractor shall share equally the costs of the mediator.
- A15.2 Nothing stated herein shall be interpreted to limit the right of the Anchorage School District to seek any remedy it may have against the Contractor as a counterclaim raised during a mediation proceeding or as an action, counterclaim or cross-claim, at law or in equity, filed in a court of law.

ARTICLE A16 **Extent of Agreement**

- A16.1 This Agreement, including any and all appendices, and any Amendments thereto, represents the entire and integrated Agreement between the Anchorage School District and the Contractor, and supersedes all prior negotiations, representations, or agreements, written or oral. This Agreement may be modified only by Amendment.

Project Name
Project Number **Insert Number**
RFP Number **Insert Number**
Revised 4-18-18

General Conditions
Appendix A

A16.2 Nothing contained in this Agreement may be deemed to create any contractual relationship between the Anchorage School District and any Subcontractor or material supplier; nor may anything contained in this Agreement be deemed to give any third party a claim or right of action against the Anchorage School District or the Contractor which does not otherwise exist without this Agreement. Nothing in this Agreement shall be construed as creating any personal liability on the part of any officer, School Board member, employee or representative of the Anchorage School District.

ARTICLE A17 Notices/Communications

- A17.1 All notices required or permitted to be given under this Agreement shall be in writing and may be emailed, hand-delivered, mailed, delivered by overnight courier service, or transmitted by facsimile. If mailed, such notices shall be sent by certified mail, postage pre-paid, return receipt requested. The date on which such notice was given shall be deemed to be the date which is two (2) Days after the date of the mailing. The post-mark affixed to such notice by a U.S. Post Office shall be conclusively presumed to be the date of mailing for purposes of this provision. In the case of notices given by hand delivery or overnight courier, such notices shall be deemed to be given on the date of the actual receipt. If transmitted by email or facsimile, such notices shall be deemed to be given on the date of the actual receipt of a complete, email or legible facsimile transmission, except that if an email or facsimile transmission is received after business hours or on the weekend or holiday, then the notice shall be deemed to be given on the next business day following the receipt of the email or facsimile transmission.
- A17.2 Notices to the Anchorage School District shall be sent to the individual identified in Article 5 of the Agreement as the Project Manager, at the email, address or the fax number indicated.
- A17.3 Notices to the Contractor shall be sent to the individual identified in Article 6 of the Agreement as the Contractor's Principal, at the email, address or fax number indicated.
- A17.4 Either party may change the address to which notices shall be sent by notice in writing to the other party.
- A17.5 The Anchorage School District shall be entitled to rely on information provided by and statements made by the Contractor's Principal identified in Article 6 of the Agreement as binding the Contractor. The Contractor shall be entitled to rely on information provided by and statements made by the Project Manager identified in Article 5 of the Agreement, or other Anchorage School District officials identified in writing, as binding the Anchorage School District.

ARTICLE A18 Taxes

A18.1 The Contractor shall pay all federal, state and local taxes incurred by the Contractor as a result of performing services required by this Agreement. The Contractor shall include this provision in any Subcontract so as to be binding on any and all Subcontractors.

ARTICLE A19 Governing Laws

A19.1 This Agreement is governed by the laws of the State of Alaska, and any applicable federal and municipal laws and ordinances. Any legal proceedings will be held in Superior Court in Anchorage Alaska. The Contractor shall at all times observe and comply with all such laws and ordinances. If any term, covenant, or condition is found by a court of law to be unenforceable, the remaining terms, covenants, and conditions shall remain in full force and effect.

ARTICLE A20 Force Majeure Suspension

A20.1 The duties and obligations of the parties to this Agreement shall be suspended during such time as performance by either party is prevented or materially impeded by strikes, labor disturbances, riots, fire, governmental act, war, acts of God, or any other causes similar to the foregoing and beyond control of the parties hereto.

ARTICLE A21 Waiver

A21.1 No delay in exercising any right or remedy of the parties hereunder shall constitute a waiver thereof, and no waiver by the Anchorage School District or the Contractor of the breach of any term, covenant or condition of this Agreement shall be construed as a waiver of any preceding or succeeding breach of the same or any other term of this Agreement. No covenant, condition, right or remedy in this Agreement may be waived or modified orally, by course of conduct or previous acceptance unless such waiver or modification is specifically agreed to in a writing executed by the Anchorage School District and the Contractor.

ARTICLE A22 Interpretation

A22.1 Each party has had the opportunity for its attorney to review and comment upon this Agreement, and therefore the terms hereof shall not be interpreted against either party.

ARTICLE A23 Miscellaneous Provisions

A23.1 For the purpose of this Agreement, unless the context clearly indicates otherwise, the singular includes the plural, and the plural includes the singular.

A23.2 The titles of all Appendices, Articles and provisions contained in this Agreement are used only for purposes of convenience and ease of reference, and shall not be interpreted to affect the contents of any provision of this Agreement.

ARTICLE A24 Additional Provisions

A24.1 The following itemized Anchorage School District design guidelines and/or standards are in effect for this Agreement. Should all or portions of subsequently issued standards be applicable to the Project covered by this Agreement, such standards will be issued by Amendment.

Project Name
Project Number **Insert Number**
RFP Number **Insert Number**
Revised 4-18-18

Contract No:
Date Prepared:

ANCHORAGE SCHOOL DISTRICT
FORMAL PROFESSIONAL SERVICES AGREEMENT

INDEX

<u>ARTICLE</u>	<u>TITLE</u>
B1	Professional Responsibilities, Standard of Care, Representations
B2	Relationship of the Parties
B3	Administrative Requirements
B4	Design Services
B5	Construction Phase Services
B6	Additional Services
B7	Anchorage School District Responsibilities
B8	Additional Provisions

ARTICLE B1 Professional Responsibilities, Standard of Care, Representations

- B1.1 The Contractor shall provide professional architectural/engineering services for the Project in accordance with the terms and conditions of this Agreement. The Contractor shall perform such services, as a professional consultant to the Anchorage School District, to carry out the activities of Project design and Construction Contract administration, and to provide the technical documents and construction observation that are necessary and desirable to complete the Project in a manner satisfactory to the Anchorage School District.
- B1.2 The Contractor shall provide all services required in this Agreement using no less than the usual and customary skill, care and judgment of a professional architectural/engineering firm that is registered in the State of Alaska and is well experienced in providing such services as the design and construction of public school buildings located within the Anchorage School District.
- B1.3 Contractor represents and agrees that (a) it is an experienced firm having the ability and skill (or that it will subcontract to obtain the services of qualified sub-consultant(s) acceptable to the Anchorage School District) that are necessary to perform the services required of it under this Agreement, including specifically, but without limitation, the design and construction of a project having the scope and complexity of the Project contemplated herein; (b) it has the capabilities and resources necessary to perform its obligations hereunder; (c) it is familiar with the current laws, rules and regulations applicable to the Project, including applicable municipal, state and federal building codes and sanitary and environmental laws, rules, regulations, and orders thereof.
 - B1.3.1 In the event the Contractor becomes aware of a change or pending change in codes, laws, rules or regulations which may affect the design or construction of the Project, the Contractor shall inform the Project Manager of the change or pending change and the possible impacts thereof on the Project.
- B1.4 The Contractor represents and agrees that the drawings, specifications and other documents prepared by it or its Subcontractors pursuant to this Agreement shall be functional for the purposes intended, and that the Project, if constructed in accordance with such drawings, specifications and other documents, will be structurally sound and a complete and properly functioning facility in

Project Name
Project Number Insert Number
RFP Number Insert Number
Revised 4-18-18

accordance with the general design intent established by the Educational Specifications.

- B1.5 The Contractor shall prepare drawings, specifications, and other documents necessary to complete the design of the Project and to meet applicable codes, laws, rules, regulations and professional standards in effect as of the date of design. The Contractor or its Subcontractors shall correct, at their own expense, any and all errors, omissions, ambiguities and conflicts in the drawings, specifications and other documents prepared by the Contractor.
- B1.6 The Contractor covenants and agrees to perform the services described in this Agreement through appropriate, competent professionals who are Contractor's staff members or Subcontractors, or the staff members of Contractor's Subcontractors, and are professionally registered when required by State of Alaska statutes. Subcontractors may include, but are not limited to, architects, structural engineers, mechanical engineers, electrical engineers, landscape architects, civil engineers, cost estimators, and others as necessary.
- B1.6.1 The Anchorage School District shall have the right to require the Contractor to exclude from providing services under this Agreement any Subcontractor, or any employee of Contractor or any of its Subcontractors, or any other person under the control of the Contractor, to whom the Anchorage School District has a reasonable objection. The Anchorage School District reserves the right to object to selection of Subcontractors based on considerations of cost, performance, special qualifications, and/or known work load relative to resources.

ARTICLE B2 Relationship of the Parties

- B2.1 The Anchorage School District has no design responsibilities of any nature under this Agreement. Additionally, the District's issuance of Design Standards and Technical Specifications guidelines and/or the District's approval or denial of deviations from said Design Standards or Technical Specifications guidelines shall not create in the District design responsibilities or obligations under this Agreement. None of the activities of the Anchorage School District are intended to supplant or conflict with the design, construction cost estimating, contract administration, construction observation, or any other services and responsibilities of the Contractor that are required under this Agreement.
- B2.1.1 The Contractor's architectural and engineering design services include, but are not limited to, cost and time estimating that are calculated to demonstrate that the Project can be constructed within the budget and time frame identified in this Agreement. Although the Project Manager may discuss or suggest changes to Contractor's cost and time estimates, such discussions or suggestions shall in no way relieve the Contractor of the responsibility of fulfilling its obligations and responsibilities therefor.
- B2.2 The Contractor, including its agents, employees and Subcontractors, is an independent contractor of the Anchorage School District, and not an agent, officer or employee of the Anchorage School District. The Contractor shall carry out its responsibilities under this Agreement and conduct itself at all times as an independent contractor, except as the authority to act as an agent of the Anchorage School District in relation to certain tasks and events may be specifically granted by the Project Manager in writing from time to time. The Contractor shall not represent itself to any third party as other than an independent contractor of the Anchorage School District at any time, except in accordance with the foregoing written authority of the Project Manager.
- B2.3 Any and all employees of the Contractor, while engaged in the performance of any services required of the Contractor under this Agreement, shall be considered employees only of the Contractor and not of the Anchorage School District, and any and all claims that may or might arise under the Workers' Compensation Act on behalf of said employees while so engaged, and any and

General Architectural and Engineering Design and Construction Phase Services

all claims made by a third party as a consequence of any act or omission on the part of the Contractor's employees while so engaged on any of the services to be rendered herein, shall be the sole obligation and responsibility of the Contractor.

- B2.4 Communications by the Anchorage School District to the Contractor relating to services performed by the Contractor may be issued or made through the Project Manager. Formal communications and submittals of the Contractor to the Anchorage School District and the Construction Contractor shall be issued or made through the Project Manager, unless otherwise directed by the Project Manager or by this Agreement. The Project Manager shall have the authority to establish procedures consistent with this Agreement, to be followed by the Contractor, and to call periodic conferences to be attended by the Contractor and its Subcontractors throughout the term of this Agreement.

ARTICLE B3 Administrative Requirements

- B3.1 The provisions contained in this Article B3 are administrative requirements of this Agreement.
- B3.2 Cost Analysis and Control. Cost analysis and cost control are primary concerns of the Anchorage School District. Provisions B3.2.1 - B3.2.6.2 are included in this Agreement in order to facilitate and promote effective cost analysis and control in relation to the Project.
- B3.2.1 The Contractor shall prepare and deliver Estimated Total Construction Costs (ETCC) to the Anchorage School District at periods designated by the Deliverables Checklist referenced in Article B4. The initial ETCC shall be reviewed by the Project Manager and revised to the extent necessary at each subsequent deliverable period at no additional cost to the Anchorage School District.
- B3.2.2 The Contractor shall provide a Project design that reflects the program as defined in Contractor's original or amended scope of work. If the Estimated Total Construction Cost exceeds the budgeted Construction Contract Award Price (CCAP), the Contractor shall at no additional cost to the Anchorage School District designate an appropriate base bid scope of Work and one or more additive alternate bid scope(s) of Work, at its own expense. The ETCC for such scopes of Work shall approximate the CCAP.
- B3.2.2.1 To the extent possible, and only when requested by and approved by the District, the Contractor shall provide additive alternates or redesign the basic bid; deductive alternates shall only be included with the approval of the Anchorage School District. Where Bid Documents require bid proposals for unit prices that exceed, or deduct from, base quantity allowances, such base allowances shall be based on specific quantity surveys and not factors.
- B3.2.3 The Anchorage School District may, at its option, obtain an independent estimate of the total construction cost based on the Contractor's design. If, in the opinion of the Project Manager, such independent estimate varies significantly from the ETCC provided by the Contractor, then the Project Manager and the Contractor shall review the discrepancies. If the Project Manager concludes that changes in the Project design are required in order to keep construction costs within the CCAP, the Contractor shall modify the Construction Contract Documents accordingly at its own expense. Contractor's modification(s) shall be carried out in a reasonable time so as not to delay the scheduled completion and occupancy of the project by the Anchorage School District.
- B3.2.4 Should the Contractor be required to redesign the Project for any reason, such redesign must be approved by the Anchorage School District.
- B3.2.5 After opening bids, the Anchorage School District may exercise any option available to it,

Project Name
Project Number **Insert Number**
RFP Number **Insert Number**
Revised 4-18-18

including without limitation the following:

- B3.2.5.1 If the lowest responsive basic bid by a responsible bidder exceeds 100% of the CCAP, (a) increase the budgeted funds and award the Construction Contract(s), or (b) reduce the Project scope and require the Contractor to redesign the Project and modify the Bid Documents accordingly for rebid at Contractor's own expense.
- B3.2.5.2 If the lowest responsive basic bid by a responsible bidder, plus all additive alternative bids, is less than 90% of the CCAP, and if the scope of the Project had previously been decreased or the quality of the materials used in the Project had previously been lessened from the Technical Specifications and Design Standards because the ETCC exceeded the CCAP, (a) award the Construction Contract(s), and (b) require the Contractor to redesign the Project and modify the Construction Contract Documents in order to return the Project to its previous scope, or the materials to their previous qualities, or both, or other mutually agreed upon adjustment. Contractor's modification(s) shall be carried out in a reasonable time so as not to delay the scheduled completion and occupancy of the project by the Anchorage School District. Such modification(s) will serve as the basis of a change order to the Construction Contract.
- B3.2.6 If the Contractor is required by the Project Manager to redesign the Project and modify Bid Documents pursuant to provision B3.2.5.1, or to redesign the Project, modify the Construction Contract Documents and prepare a change order to the Construction Contract pursuant to provision B3.2.5.2, such redesign, modification and change order preparation shall be performed at Contractor's own expense, unless one or more of the following conditions exist:
- B3.2.6.1 The required redesign, modification and preparation is made necessary as the result of a prior redesign or modification directed by the Project Manager following an independent estimate of total construction cost pursuant to provision B3.2.3.
- B3.2.6.2 The required redesign and modification is the result of the lowest responsive bid by a responsible bidder being more than 100% of the CCAP, and (a) the Contractor notified the Project Manager in writing prior to completing the Construction Contract Documents that the CCAP would probably be insufficient for award of the basic bid and no action was taken by the Project Manager to resolve the matter, or (b) because the bid opening date was delayed, for reasons not the fault of the Contractor, more than ninety (90) days after the Project Manager's receipt of the ETCC submitted as part of Construction Document Services.
- B3.3 Time for Performance, Delays Timely provision of a Master Time Schedule, as defined in Appendix A, is a material requirement of this Agreement. If such a schedule is not included in Appendix F herein, Contractor shall develop and deliver it prior to the first billing for design services to the Anchorage School District, but in no event later than thirty (30) days after award of contract to the Contractor. Contractor shall coordinate Master Time Schedule with Anchorage School District's anticipated date for occupancy of Project.
- B3.3.1 The Contractor shall not deviate from the Master Time Schedule unless, in accordance with and under the conditions set forth in Article A6 ("Changes to the Agreement"), one of the following conditions is met: (a) an Amendment incorporating such change of schedule is negotiated and signed by both parties hereto, or (b) a modification to the

General Architectural and Engineering Design and Construction Phase Services

Master Time Schedule is agreed upon and signed by both parties. Contractor shall accordingly modify and submit a revised Master Time Schedule prior to submission of any subsequent billing to the Anchorage School District.

- B3.3.1.1 Should the Project Manager reasonably determine that the Contractor is behind schedule, and so notify the Contractor, the Contractor shall accelerate its efforts at its own expense, including using additional manpower or overtime, or both, to maintain the approved Master Time Schedule.
- B3.3.2 The Contractor shall not be held liable for damages incurred by the Anchorage School District due to a failure by the Contractor to meet any deadline established by the Master Time Schedule, provided that such failure arises out of a cause(s) beyond the control and without the fault or negligence of the Contractor. Such causes may include but are not limited to: Acts of God or of the public enemy, acts of a governmental entity acting in its sovereign or proprietary capacity, acts of the Anchorage School District acting in its contractual capacity, fires, floods, epidemics, quarantine restrictions, strikes, and weather that is unusually severe for the location(s) in which the Contractor is to perform its services. In the event of any such delay, Contractor shall provide to the Project Manager a written request for time extension by Amendment or modification to the Master Time Schedule in accordance with Article A6 ("Changes to the Agreement"). Except as provided in this provision B3.3.2, the Anchorage School District shall have all other contractual rights and remedies available to it at law or in equity in the event of Contractor's failure to perform this Agreement in a timely manner.
- B3.3.3 Contractor shall not be entitled to any damages for delay from the Anchorage School District, whether caused by the Anchorage School District, or the Construction Contractor or another third party. Contractor's sole remedy for delay is a reasonable time extension granted by the Project Manager in an Amendment or modification to the Master Time Schedule pursuant to Article A6 ("Changes to the Agreement").
- B3.3.4 In the event of a suspension in service directed by, or as a result of, the Anchorage School District, upon resumption of services, if any, the Contractor shall be required to review, revise and deliver the Master Time Schedule. Contractor shall be compensated for same based on stipulated sum pursuant to Article A6 ("Changes to the Agreement").
- B3.4 Conformance with ASD guidelines. The Anchorage School District's Technical Specifications and Design Standards are intended as guidelines. The Contractor shall review these guidelines. The Contractor's use of such guidelines without written notice of exception shall constitute Contractor's acceptance of the guidelines. If the Contractor proposes deviations from these guidelines, such deviations shall be justified to the Anchorage School District in writing. The Anchorage School District retains the right to accept or reject such deviations, the Contractor shall modify the Construction Contract Documents accordingly at its own expense. The Contractor shall incorporate and coordinate the referenced guidelines into the Project.
- B3.5 Document Preparation and Submission Procedures. Contractor's compliance with the procedures and requirements set forth in provisions B3.5.1 - B3.5.9 concerning document preparation and submission is mandatory, except as may be specifically modified in writing by the Project Manager.
- B3.5.1 All drawings and specifications submitted for review and approval shall be marked as "Schematic Development Review Set," "Design Development Review Set," "Construction Document Review Set," or similar phrase, as appropriate. The original set used to duplicate the Bid Documents shall be marked and issue dated as directed by the Anchorage School District.
- B3.5.1.1 Technical specifications shall be provided in the current C.S.I. format.

- B3.5.1.2 Specifications shall be provided digitally in pdf and the current version of Microsoft Word used by the Anchorage School District.
- B3.5.2 All Construction Contract Documents shall bear the Anchorage School District's Project number and title, and shall be signed or initialed by the Contractor to acknowledge that the submissions have been checked by the Contractor for accuracy, completeness and coordination.
- B3.5.3 Electronic media drawing files shall be developed or usable in current version of AutoCAD used by the Anchorage School District, or as determined by the Project Manager in consultation with the Contractor.
- B3.5.3.1 Fonts used in drawing data bases shall be standard AutoCAD fonts, or Contractor shall supply the Anchorage School District with a licensed copy of font files used.
- B3.5.3.2 Contractor shall conform drawing production data classifications to the current version of the "United States National CAD Standard", except as otherwise approved by the Project Manager for project-specific requirements. Information regarding this Standard is available at: <http://www.nationalcadstandard.org>.
- B3.5.4 Contractor shall provide drawing files on writable CD-ROM disk(s), labeled with the Anchorage School District's Project name and number, and drawing numbers, dates, and phase status.
- B3.5.5 During design phases, Contractor shall provide digital progress drawings, as pdf, in sizes and quantities as agreed to by Project Manager and Contractor.
- B3.5.6 Contractor shall provide one complete set of final reproducible drawings each for Bid Document issuance and, subsequently, for Conformed Documents digitally in sizes as agreed to by Project Manager and Contractor.
- B3.5.7 At the completion of construction of the Work as provided by B5.17, the Contractor shall provide one complete set of Record Drawings both hard copy and electronically on writable CD-ROM disk(s).
- B3.5.8 The Contractor shall not delegate or transfer in any way through the Bid Documents any service required of it by this Agreement, unless such delegation or transfer is submitted prior to the Construction Document phase and approved in writing by the Project Manager. Any performance specifications which require design services by the Construction Contractor or one of its subcontractors, or by a third party, or which require instruction (such as from a manufacturer, supplier or installer) shall state that the Contractor must review and approve all such designs or instructions for conformance with design intent.
- B3.5.9 "Brand Name", "Sole Source", or proprietary specifications shall not be used in the Bid Documents except when directed by the Project Manager, or when justified by the Contractor and approved by the Project Manager. Basis shall be replacement inventory, compatibility with existing systems, spatial parameters, previous performance history, and/or Anchorage School District Technical Specifications and Design Standards. "Brand Name or Equal as approved by Architect or Engineer" specifications may be used in Bid Documents as a means to define the performance or other salient requirements of an item, if the specific features of the brand name establish the minimum essential characteristics required to satisfy its intended use and the same is clearly stated in the

General Architectural and Engineering Design and Construction Phase Services

specifications. During construction, Contractor shall conform with Article B5.4.2 for substitution of specified products.

- B3.6 Review, Comment. The District's review of drawings and specifications may generate comments directed to the Contractor which are designated by the following classifications and which require certain types of action by the Contractor as indicated below:

Class I comments pertain to real or potential code or regulation violations, and require the Contractor's response by means of modification or formal written approval or variance from the regulatory agency. Any such approval or variance from the regulatory agency shall be copied to the Project Manager.

Class II comments pertain to errors, omissions, matters of document coordination, or deviations from Anchorage School District's Technical Specifications and Design Standards, and require the Contractor's correction of the documents, unless justification satisfactory to the Project Manager is provided in writing by the Contractor.

Class III comments pertain to matters of design judgment and are offered in a positive manner with the intent of improving the design result. These comments are not directions for design changes, but are provided as suggestions for consideration by Contractor as the Contractor may deem appropriate. These comments do not require any revision of the documents by the Contractor. However, they do require response by the Contractor justifying action taken.

- B3.7 Presentation, Approval, Acceptance. Notwithstanding presentation requirements of other regulatory agencies, the Contractor shall present Conceptual Design (when required) and subsequently Schematic Design documents to the Anchorage School Board at a regularly scheduled Board Meeting to obtain Board approval before proceeding with services for subsequent phase. At least three weeks prior to the anticipated Board meeting, the Contractor shall submit presentation drawings as defined by the attached Deliverables Checklist and shall notify the Project Manager that the Contractor will be ready to make the presentation to the School Board at the regularly scheduled meeting.

B3.7.1 Approval of the Contractor's design and document submissions by the Project Manager, the Anchorage School District, or the Anchorage School Board constitutes approval of the basic design concept and layout only, and does not relieve the Contractor of the responsibility for preparing a complete set of Construction Contract Documents in accordance with the terms of this Agreement.

B3.7.2 Acceptance by the Project Manager, the Anchorage School District, or the Anchorage School Board of the Contractor's design and document submissions is not an approval of any Contractor omissions, errors, conflicts, oversights or noncompliance with any applicable governmental laws or regulations. The Anchorage School District shall not be liable for failure to identify any such omissions, errors, conflicts, oversights, or noncompliance. All such responsibility belongs to the Contractor.

ARTICLE B4 Design Services

- B4.1 The Contractor shall provide all the design services described within this Article B4 ("Design Services"). Design Services shall consist of Conceptual Design Services (when required), Schematic Design Services, Design Development Services, Construction Document Services and Bid Services described herein, except that any such service may be modified or deleted in Article B8 ("Additional Provisions"), or deleted by a notation in the left margin of Article B4 which is initialed by both parties.

Project Name
Project Number **Insert Number**
RFP Number **Insert Number**
Revised 4-18-18

- B4.1.1 The Contractor shall provide Deliverables as indicated on the attached Deliverables Checklist (Attachment A to PSA Appendix B) as negotiated within the Scope of Services by the Contractor and Project Manager.
- B4.1.1.1 Where indicated on the Deliverables Checklist, drawings showing preliminary master plan development, site plan layout, building plan layouts, preliminary building cross-sections, exterior elevations, and interior elevations of salient features shall be provided in both full size and 8-1/2 x 11" format (or as otherwise directed by Project Manager) for presentation to the Anchorage School Board.
- B4.1.1.2 Where three-dimensional control coordinates are indicated on the Deliverables Checklist, Contractor shall provide same for all critical control coordinates (i.e., tangent points, property corners, curvature points, grade breaks, horizontal and vertical control monuments, inverts, flow lines, etc.) CADD drawings shall include all disciplines referenced to the same geometric base. Should the Municipality of Anchorage require that certain drawings reflect a different basis of control than that selected by the Contractor, appropriate equation(s) shall be provided by the Contractor allowing coordination on either data base(s).
- B4.1.1.3 Where indicated on the Deliverables Checklist, the Contractor shall review, approve and submit to the Project Manager Estimated Total Construction Costs of the Project, based on historic area, volume or other unit costs, construction sequence and scheduling, economic tradeoffs, safety and maintenance requirements, and such other factors as may be appropriate.
- B4.1.2 The Contractor shall serve as a member of the Municipality of Anchorage Art in Public Places program's Art Advisory Committee to determine specific sites for work(s) of art and the scale and type of artwork most appropriate for the Project.
- B4.1.2.1 The Contractor shall work closely with artist(s) and artist's (artists') consultants approved by the Anchorage School District to identify and coordinate the structural, utility or other requirements which interface with Contractor's work for selected work(s) of art for inclusion in the Bid Documents.
- B4.1.3 The Contractor shall prepare and submit all Deliverables necessary to obtain all preliminary reviews or approvals required: by governmental entities that have regulatory and jurisdictional power over the Project through applicable laws, statutes, regulations and codes; by privately-owned utility companies or other entities which may impose conditions on the Project; and by such other entities as may be identified by the Project Manager.
- B4.1.4 As part of its risk management program, the Anchorage School District requires submittal of Construction Documents to its property and casualty insurer ("Insurer") for review and comment. Upon receipt of Insurer's review comments, the District will evaluate issues raised and address with the Contractor. The Contractor shall become familiar with applicable Insurer standards and endeavor to comply with those standards.
- B4.2 When required, Conceptual Master Plan Services shall consist of the preparation and presentation of Deliverables which illustrate and describe the general master planning scope, scale and relationship of program components based on Educational Specifications for approval by the Anchorage School District.

- B4.3 Schematic Design Services shall consist of the preparation and presentation of Deliverables which illustrate and describe the general scope, scale and relationship of Project components based on the program, approved Master Time Schedule, and Construction Contract Award Price, for approval by the Anchorage School District.
- B4.3.1 The Contractor shall review the Educational Specifications, Technical Specifications and Design Standards, and other pertinent documents furnished by the Anchorage School District to ascertain the requirements of the Project.
- B4.3.2 The Contractor shall develop initial design concepts and options for the Project in close coordination with the Anchorage School District. The Contractor shall identify unusual structural, mechanical, electrical or other features that may impact costs or use, and shall develop the systems selected in sufficient detail to permit coordination among design elements.
- B4.3.3 In order to inventory existing site conditions, the Contractor shall request a Project site visit and propose an itinerary. Following the Project Manager's written approval of the Contractor's request, the Contractor's principal, and other personnel as may be designated, shall visit the Project site.
- B4.3.4 When the Construction Contract Documents are approximately thirty-five percent (35%) complete, the Contractor shall submit to the Project Manager one complete set of reproducible drawings for review.
- B4.4 Design Development Services shall be based on the approved Schematic Design, and shall consist of the preparation, for approval by the Anchorage School District, of Deliverables to fix and describe the size and character of the entire Project with regard to structural, mechanical and electrical systems, materials and such other essentials as may be appropriate. Design Development Services shall include a detailed expansion of the architectural design so that the Project's size, appearance, form, construction type, and engineering systems are developed. Major material selections, equipment items, and quality of finishes shall be identified.
- B4.4.1 When the Construction Contract Documents are approximately sixty-five percent (65%) complete, the Contractor shall submit to the Project Manager one complete set of reproducible drawings for review.
- B4.5 Construction Document Services shall be based on the approved Design Development Deliverables, and shall consist of the preparation, for approval by the Anchorage School District, of Deliverables, setting forth in detail the requirements for construction of the entire Project. Deliverables shall establish the detailed quality levels and extent of materials and systems sufficient for both bidding and construction of the Work.
- B4.5.1 The Contractor shall prepare and coordinate a complete set of Construction Contract Documents for the Project in accordance with the current Construction Specifications Institute Manual of Practice, except as provided by the Anchorage School District and enumerated below.
- B4.5.1.1 The Contractor shall prepare applicable technical specifications (Divisions 2-17), an index of drawings, and drawings for inclusion in the Construction Contract Documents. The Anchorage School District will provide Conditions of the Contract (Division 0), with the exception of the index of drawings, and will transmit an informational copy to Contractor. The Contractor and the Project Manager shall jointly prepare General Requirements (Division 1) in a coordinated effort. All documents and specifications are to be complementary and compatible.

- B4.5.2 When the Construction Contract Documents are approximately ninety-five percent (95%) complete, the Contractor shall submit to the Project Manager one complete set of reproducible drawings for review.
- B4.5.3 The Contractor shall review, approve and submit to the Project Manager, when the Construction Contract Documents are ninety-five percent (95%) complete, an updated and revised Estimated Total Construction Cost, based on materials, systems and details of construction, and which considers changes in the cost of materials, labor and services discovered since submission of the previous Estimated Total Construction Cost; adjustments for anticipated changes in the bidding market relative to the Project; and such other factors as may be appropriate.
- B4.6 Bid Services shall be based on the approved Construction Contract Documents, and shall consist of assisting in the preparation, for approval by the Anchorage School District, of Bid Documents for obtaining bids and awarding contract(s) for construction of the Project.
- B4.6.1 Upon direction by the Project Manager, the Contractor shall prepare responses to bidders' questions or requests for clarification or interpretation of Bid Documents. The Contractor shall not respond directly to any bidder's question or request for clarification or interpretation. All questions and requests for clarifications or interpretations as to the meaning of the information in the Bid Documents must be in writing, with responses by the Contractor provided to the Anchorage School District and retained in the Contractor's records. The Contractor shall not respond to bidders' oral questions and requests for clarifications except in writing.
- B4.6.2 The Contractor shall prepare and deliver copy-ready and electronically, as defined by Article B3.5, any addenda to the Bid Documents which may be necessary to clarify or supplement drawings, specifications, or instructions, or to provide notice of any change in bidding procedures. All addenda will be distributed by the Anchorage School District during the bidding period.
- B4.6.3 As directed by the Project Manager, the Contractor shall participate in pre-bid conferences, the bid opening, the review and evaluation of bids, and the recommendation for award of the Construction Contract(s).
- B4.6.4 Contractor shall provide Conformed Documents within 30 days of bid opening, unless the Anchorage School District approves an extension in writing, which extension shall not exceed 15 days. Conformed drawing items shall be identified by clouds referenced with revision numbers in triangles and corresponding revision dates in drawings' title blocks. Conformed technical specification items shall be italicized with footers referencing revision and date. Contractor shall submit Conformed Documents to applicable permitting agencies for their approval, and shall provide Project Manager both half-sized and full-sized pdf copies of Conformed Documents for issuance to Construction Contractor.
- B4.7 Permitting Services shall be provided as assistance to ASD and based on approved Construction Contract Documents submitted to the Municipality and/or others for permitting. Contractor shall review all building (or any other applicable) permit comments and respond/resolve all comments pertaining to Contractor's Scope of Work.

ARTICLE B5 Construction Phase Services

- B5.1 Construction Phase Services shall consist of providing such Construction Contract administration services and construction observation services during the construction of the Project as are

General Architectural and Engineering Design and Construction Phase Services

described in this Article B5. Construction Phase Services shall commence with the award of the Construction Contract and shall terminate with the Anchorage School District's final acceptance of the Project, or approval of the Contractor's final invoice pursuant to the Contractor's satisfactory completion of obligations under this Agreement, whichever is later.

- B5.2 As directed by the Project Manager, the Contractor shall participate in pre-construction conferences with the successful bidder.
- B5.3 The Contractor shall consult with the Project Manager regarding the acceptability of the supervisory personnel, subcontractors and suppliers proposed by the Construction Contractor for various portions of the Work.
- B5.4 The Contractor shall review and approve or take other appropriate action on schedules, shop drawings, samples, schedules of values, and other submissions of the Construction Contractor(s), as well as the Work performed by the Construction Contractor(s), for conformance with the design concept of the Project and for compliance with the Construction Contract Documents.
- B5.4.1 The Contractor shall provide a submittal register listing the submittals required in format provided by Project Manager. The Contractor shall review and return submittals to the Construction Contractor expeditiously, but no later than fourteen (14) Days from date of receipt, except when otherwise authorized by the Project Manager. The Contractor shall coordinate directly with the Construction Contractor to obtain all submittals required by the Construction Contract Documents, and shall promptly notify the Project Manager concerning any submittals, or lack of submittals, which may affect the Project. The Contractor's approval of submittals must be in writing to the Project Manager and copied to the Construction Contractor. Approvals must contain Contractor's recommendation regarding any credit due the Anchorage School District for an item substituted by the Construction Contractor.
- B5.4.2 The Contractor shall submit to the Anchorage School District for acceptance all recommended approvals for substitutions of specified products proposed by the Construction Contractor.
- B5.5 The Project Manager will establish with the Contractor procedures to be followed for the review and processing of all the Construction Contractor's shop drawings, catalog submissions, Project reports, test reports, maintenance manuals, and other necessary documentation, as well as the Construction Contractor's requests for change orders and applications for extensions of time.
- B5.6 The Contractor shall render to the Project Manager with reasonable promptness, interpretations of the requirements of the Construction Contract Documents which are submitted by the Construction Contractor as Requests for Information (RFIs). The Contractor's interpretations shall be consistent with the intent of, and reasonably inferable from, the Construction Contract Documents. The Contractor's decisions in matters relating to artistic effect shall be consistent with the intent of the Construction Contract Documents. The Contractor's decisions set forth in response to RFIs which impact cost and schedule shall be approved by the Project Manager prior to the Contractor transmitting them to the Construction Contractor. The Contractor shall coordinate with the Anchorage School District's logs of RFIs, Proposal Requests, and Change Orders using owner-provided construction management software.
- B5.6.1 Should errors, omissions or conflicts in the drawings, specifications or other Construction Contract Documents be discovered which are due to the Contractor's fault, the Contractor shall prepare and submit to the Project Manager such amendments or supplementary documents and provide such consultation as may be required, for which the Contractor shall make no additional charge, but may be subject to claim, from the Anchorage School District.

- B5.7 As directed by the Project Manager, the Contractor shall research, review, and recommend for approval or disapproval the Construction Contractor's responses to requests for proposals or requests for change orders to the Construction Contract, and participate in Change Order negotiations.
- B5.8 The Contractor will have access to the Work at all reasonable times. All site visits, observations, and other on-site activities by the Contractor shall be coordinated through the Project Manager.
- B5.9 The Contractor is not responsible for construction means, methods, techniques, sequences or procedures, or for safety precautions and programs in connection with the Work. Contractor is not responsible for any failure by the Construction Contractor to carry out the Work in accordance with the Construction Contract Documents. Nothing stated herein absolves the Contractor from the responsibility of observing construction to ascertain conformance of the Work with the Construction Contract Documents, as required herein.
- B5.10 The Contractor shall make periodic visits to the construction site to observe the Work, per the agreed upon schedule, for conformance with the Construction Contract Documents. Such visits shall be timed to coincide with the Project Manager's construction progress meeting with the Construction Contractor. A representative from each engineering discipline shall make periodic visits to the construction site no less than once every two weeks during the course of Work applicable to that discipline. Contractor shall not be required to make extensive or full-time on-site observations to check the quality or quantity of the Work as part of Basic Services, but shall make as many observations as may be reasonably required to fulfill its obligations to the Anchorage School District hereunder. The Contractor and each representative from each engineering discipline shall prepare a written field report on each visit and observations of the Work made during each visit. Each field report shall be submitted via the Contractor to the Project Manager, in a form acceptable to the Project Manager, within two (2) working Days of the respective visit.
- B5.10.1 In addition to the foregoing, each of the engineering disciplines may be required by the Project Manager to make extended visits or have full-time personnel at the job site during critical phases of the Work. Such extended visits or full-time observation at the job site shall be Additional Services when directed, by written authorization, by the Project Manager.
- B5.11 On the basis of on-site observations, the Contractor shall take the appropriate steps to attempt to guard the Anchorage School District against defects and deficiencies in the Work of the Construction Contractor. If the Contractor observes any Work that does not conform to the Construction Contract Documents, the Contractor shall immediately make an oral report of all such observations to the Project Manager. The Contractor shall confirm the non-conformance in writing to the Project Manager within three (3) Days of such observation.
- B5.12 Only the Project Manager shall have authority to condemn or reject Work when in the Project Manager's or the Contractor's opinion the Work does not conform to the Construction Contract Documents. Such condemnation or rejection will be by written notice delivered to the Construction Contractor. Whenever, in the Project Manager's or the Contractor's reasonable opinion, it is considered necessary or advisable to ensure the proper implementation of the intent of the Construction Contract Documents, the Project Manager shall have the authority to require special inspection or testing of any Work in accordance with the provisions of the Construction Contract Documents, whether or not such Work is fabricated, installed or completed.
- B5.13 Based upon observations at the site and upon the Construction Contractor's applications for payment, the Contractor shall determine the amount it believes the Anchorage School District owes the Construction Contractor(s) pursuant to the terms of the Construction Contract, and shall within seven (7) Days after receipt of an application for payment from the Construction Contractor, submit to the Project Manager a signed certificate for payment in such amount.

General Architectural and Engineering Design and Construction Phase Services

- B5.13.1 The Contractor's signing of a certificate of payment shall constitute a representation by the Contractor to the Anchorage School District, based upon the Contractor's observations at the site and the data comprising the application for payment, that the Work has progressed to the point indicated, that to the best of the Contractor's knowledge, information and belief, the quality of the Work appears to be in accordance with the Construction Contract Documents (subject to: an evaluation of the Work for conformance with the Construction Contract Documents upon Substantial Completion; the results of any subsequent tests required in accordance with the Construction Contract Documents; minor deviations from the Construction Contract Documents correctable prior to completion; and to any specific qualifications stated in the recommendation); and that the Construction Contractor is entitled to payment in the amount stated in the recommendation. When required by the State of Alaska Department of Education and Early Development, and at the Project Manager's direction, the Contractor will provide the Project Manager with written certification when the Construction Contract is 50% complete in a format provided by the Project Manager.
- B5.13.2 By signing a certificate for payment to the Anchorage School District, the Contractor shall not be deemed to represent that it has made any examination to ascertain how and for what purpose the Construction Contractor has used the moneys paid on account of the Construction Contract.
- B5.13.3 The Project Manager shall consult with the Contractor regarding the determination of the amount due the Construction Contractor, and shall approve or disapprove the certificate for payment.
- B5.14 The Contractor shall, when directed by the Project Manager, research, review and make recommendations regarding any claim submitted by the Construction Contractor.
- B5.15 The Contractor shall be responsible for obtaining governing agency approval of its designs. If any exceptions arise related to the design, the Contractor shall endeavor to resolve the exception with the governing agency and provide its design services to correct the situation at no additional cost to the Anchorage School District. The Contractor shall not be liable for costs of design services if the exceptions are subsequent contradictions to a governing agency's previous approval and/or if the exceptions appear to be unreasonable in the Project Manager's judgement.
- B5.16 Upon direction by the Project Manager following notice by the Construction Contractor that the Work (or portions of the Work) are substantially complete, the Contractor shall inspect the Work (or portions of the Work) and prepare and submit to the Project Manager typed punch lists of the Work which is not in conformance with the Construction Contract Documents. The Project Manager will transmit such punch lists to the Construction Contractor(s).
- B5.17 Upon direction by the Project Manager, following notice by the Construction Contractor that the Work or portions of the Work are finally complete, the Contractor shall conduct final completion inspections. Upon correction of all punch list items and acceptance of all other close-out submittals and certificates of the Construction Contractor, the Contractor shall approve the Construction Contractor's application for final payment and submit the signed certificate of final payment to the Project Manager for review and approval.
- B5.18 The Contractor shall review and approve for completeness, clarity and accuracy, As-builts provided by the Construction Contractor showing significant changes in the Work made during the construction process, based on neatly and clearly marked-up conformed contract drawings, prints, and other data furnished by the Construction Contractor(s), responses to RFI's, periodic site visits, and change orders which occurred during the Work. Contractor shall deliver to the Project Manager a reproducible set of the approved Record Drawings and such electronic copies as are required by provision B3.5.7 herein.

Project Name
Project Number **Insert Number**
RFP Number **Insert Number**
Revised 4-18-18

ARTICLE B6 Additional Services

- B6.1 The Architect shall provide selected Additional Services described in this Article B6, or as may be modified or supplemented in Article B8, only when the basis for ascertaining the compensation for such services is included either in Appendix C hereto or by subsequently issued Addenda and the services are authorized by a Notice(s) to Proceed.
- B6.2 Additional Services may include, but are not limited to, the following:
- B6.2.1 Upon the completion of the Schematic Design Services, the remaining Design Services may be divided to facilitate the bidding of separate trade contracts or the release of phased construction activities. The Project Manager shall have the right to determine whether there will be early, late, or phased release of construction contracts to meet funding and other Project constraints.
 - B6.2.2 Performing geotechnical site investigations, surveys, and/or platting services.
 - B6.2.3 Performing on-site observations of the Work which require extended visits or full-time personnel at the job site.
 - B6.2.4 Performing a preliminary energy audit in a format approved by the Project Manager. If the preliminary energy audit discloses opportunities for energy conservation, the Contractor shall develop and submit to the Project Manager a proposal to perform a detailed energy audit to identify technical solutions and the projected economic benefit of those solutions.
 - B6.2.4.1 If the Anchorage School District accepts a proposal submitted in accordance with provision B6.2.4, an Amendment covering the performance of the detailed energy audit must be executed before the Contractor will be entitled to any compensation therefor.
 - B6.2.4.2 If a detailed energy audit identifies economical solutions to conserve energy, the Contractor and the Anchorage School District may execute an Amendment covering the preparation of the necessary design and the inclusion of such design requirements in the Bid Documents within the basic bid or as an additive alternative bid.
 - B6.2.5 Providing start-up Commissioning assistance, including on-site observations and review of test data regarding the original operation of any equipment, and the operation of building systems during the initial occupancy and subsequent periods until proper operations are established. Such assistance may include determining responsibility for corrective measures or procedures as may be needed. If Commissioning reveals deficiencies caused by the Contractor's design, Contractor shall provide design services to correct the deficiencies at no additional cost to the Anchorage School District.
 - B6.2.6 Providing warranty inspections, as required, through the scheduled completion of the warranty period specified in the construction contract.
 - B6.2.7 Preparing an environmental assessment of the Project: obtaining federal, state and local review which must be obtained in accordance with applicable laws and regulations, and revising as necessary.
 - B6.2.7.1 Preparing an environmental impact statement (EIS) for the Project; obtaining federal, state and local reviews which must be obtained in accordance with applicable laws and

General Architectural and Engineering Design and Construction Phase Services

regulations; revising as necessary; preparing any necessary design requirements; and, including such design requirements in the Bid Documents within the basic bid or as an additive alternate bid.

- B6.2.8 Preparing Educational Specifications which conform to Anchorage School District Design Standards and Department of Education and Early Development requirements.
- B6.2.9 Preparing a Life Cycle Cost analysis and recommendations for materials and building systems to be considered as alternatives to those established by Anchorage School District Design Standards and Technical Specifications.

ARTICLE B7 Anchorage School District Responsibilities

- B7.1 The Anchorage School District shall, as applicable, provide the Educational Specifications for the Project, unless this task is identified as an Additional Service to be undertaken by the Contractor.
- B7.2 The Anchorage School District shall provide the Contractor with access to the land on which the Project is to be constructed and the Work of the Construction Contractor as may be required in order for the Contractor to perform its services required under the Agreement.
- B7.3 The Anchorage School District shall review documents submitted by the Contractor and render decisions pertaining thereto with reasonable promptness.
- B7.4 The Anchorage School District shall furnish information and responses to Contractor's requests for approvals with reasonable promptness.
- B7.5 The Anchorage School District shall provide all notices and advertisements inviting bids.
- B7.6 The Anchorage School District shall provide all standard construction contract forms for incorporation into the Bid Documents.
- B7.7 The Anchorage School District shall duplicate and distribute Bid Documents.
- B7.8 The Anchorage School District shall receive and open bids and provide tabulation of bids.
- B7.9 The Anchorage School District shall pay directly, or through the Construction Contractor, for all permits, licenses, approvals, easements, assessments, and charges required for the construction, use or occupancy of permanent structures or for permanent changes in existing facilities.
- B7.10 The Anchorage School District shall pay for such structural, mechanical, chemical and other laboratory tests, inspections and reports as are required by law and which are not required to be paid by Contractor in this Agreement.
- B7.11 The Anchorage School District shall decide all claims and disputes involving the Construction Contractor and the Anchorage School District, following its review of any related facts and recommendations submitted by the Contractor.
- B7.12 The Anchorage School District shall furnish such legal, accounting, and insurance counseling services as it may deem necessary to preserve its interests in the Project.

ARTICLE B8 Additional Provisions

- B8.1 None

Project Name
Project Number **Insert Number**
RFP Number **Insert Number**
Revised 4-18-18

Instructions: 1. Please indicate Scope of Services by marking an "X" where included as part of the project.
2. Please DO NOT DELETE the non-used Scope of Services, use the strikethrough effect instead of deleting them.
3. Add and edit the project Scope of Services as needed.

School/Building Name **Insert**
Date Prepared **Insert**

Schematic Phase	Design Development Phase	Construction Document Phase
-----------------	--------------------------	-----------------------------

NARRATIVE* - Executive Summary for Review
 * = Each successive phase includes items from the previous phase; transfer technical and design data and keynotes from Narrative to DD and CD Drawings
 ** = When Conceptual Master Plan Design is required, provide and update at Schematic Design phase.
 (a) = See FPSA Article B4.1.1.1

**Outline project objectives and process		
**Describe design concept		
**Compare proposed program space to ASD Educational Specifications, tabulating required and proposed areas and teaching stations in format acceptable to District	Update and finalize tabulations	Finalized tabulations
Provide regulatory summary, describing design requirements related to all applicable building and zoning/land use codes and regulations, including local amendments: such as Title 21 implications	Update and finalize regulatory summary	Finalized regulatory summary
Describe thermal envelope, giving R-values for roof, walls, grade floors	Finalize thermal envelope design R-values	Finalized thermal envelope design R-values
Define Energy Budget (EB) based on comparable existing facility	Compare and finalize proposed design to EB	Finalized proposed design to EB
Discuss adequacy of Owner-furnished data and identify additional information required.	Discuss adequacy of Owner-furnished data and finalize additional information required.	Finalized required information
Chart Master Time Schedule. Using Microsoft Project. Include tasks, responsibilities, and the following Milestones as applicable: a/e selection; contract negotiations; budget analysis; Ed Spec verification; programming/concept design; site analysis; schematic design; design development; construction documents; all cost estimates; all agency reviews; permitting; bidding; conformed documents; construction award; phasing; construction; commissioning; occupancy	Update Master Time Schedule with each invoice.	Update Master Time Schedule with each invoice. Provide estimates of construction durations for basic bid and major additive alternate Work. Provide basis of duration estimate(s).
**Provide Estimated Total Construction Cost		

Instructions: 1. Please indicate Scope of Services by marking an "X" where included as part of the project.
2. Please DO NOT DELETE the non-used Scope of Services, use the strikethrough effect instead of deleting them.
3. Add and edit the project Scope of Services as needed.

School/Building Name **Insert**
Date Prepared **Insert**

Schematic Phase		Design Development Phase		Construction Document Phase	
	Geotechnical report and recommendations		Geotechnical report and recommendations		Geotechnical report and recommendations
NARRATIVE* - Detailed Provisions for Review					
* = Each successive phase includes items from the previous phase; transfer technical and design data and keynotes from Narrative to DD and CD Drawings					
** = When Conceptual Master Plan Design is required, provide and update at Schematic Design phase.					
(a) = See FPSA Article B4.1.1.1					
	Relate proposed design to ASD Technical Specifications and Design Standards criteria, justifying any deviation.		Relate proposed design to ASD Technical Specifications and Design Standards criteria, justifying any deviation.		Relate proposed design to ASD Technical Specifications and Design Standards criteria, justifying any deviation.
	Utility services existing and required for both temporary and permanent construction.		Utility services existing and required for both temporary and permanent construction.		Utility services existing and required for both temporary and permanent construction.
	Research hazardous materials history, identifying any known hazardous materials, and identifying potential scope of work.		Investigate, assess, delineate and quantify materials. Propose abatement methods.		Detail hazardous material removal or abatement methods.
	Describe proposed exterior and interior architectural materials, assemblies, systems and finishes.		Submit manufacturers data, catalog cut sheets, and regulatory approvals or tests as required.		
	Structural considerations, including seismic analysis of existing buildings and proposed strengthening techniques, floor and roof structural framing live and dead loads analysis.		Structural analysis and calculations		Update Structural analysis and calculations
	Describe mechanical design parameters, referencing Energy Budget. Describe design parameters and project scope for the following systems: heating, ventilation, air conditioning (HVAC), fire sprinkler, plumbing, and controls. For renovation projects clearly indicate which systems will or will not be included in the scope of the project.		Mechanical engineering type of heating system, heat loss and gain load calculations; cut sheets of major heating, ventilation and plumbing components.		Update mechanical engineering loads, calculations and cut sheets of major components.
	Air flow diagram showing where the (existing and new) air is going in the building and relief/exhaust/static, etc information		Verify and update the Air flow diagram		Final narrative

Instructions: 1. Please indicate Scope of Services by marking an "X" where included as part of the project.
2. Please DO NOT DELETE the non-used Scope of Services, use the strikethrough effect instead of deleting them.
3. Add and edit the project Scope of Services as needed.

School/Building Name **Insert**
Date Prepared **Insert**

Schematic Phase		Design Development Phase		Construction Document Phase	
	Describe water service, sewer service and storm drain system connections to coordinate with utility and site Civil Design.		Update narrative.		Finalize narrative.
	Describe roof rain leader systems and connections with storm water system (drywell if any)		Update roof rain leader systems and connections with storm water system (drywell if any) per reports and recommendations.		Update roof rain leader systems and connections with storm water system (drywell if any)
	Provide video footage and drain inspection report (and rain leader pressure jet cleaning report) for roof STORM WATER drainage system. Reports to define work performed and recommendations.		Update narrative per reports and recommendations.		Update
	Provide video footage and drain inspection report (and sewer piping pressure jet cleaning report) for SEWER drainage system. Reports to define work performed and recommendations.		Update narrative per reports and recommendations.		Update
	Describe plumbing systems. Describe HVAC systems. Define any special systems for project including but not limited to well systems, fire pumps, fuel oil systems (or alternate fuel), propane systems and compressed air..		Update plumbing systems. Update HVAC systems.		Update plumbing systems. Update HVAC systems.
	Define Energy Conservation Measures, including Life Cycle Cost analysis (see Article B6), renewable energy options.		Update ECM and LCC analysis.		Update ECM and LCC analysis.
	Describe proposed controls systems, and coordination with existing where applicable.		Outline controls system and coordination with existing where applicable. Including but not limited to, roof drainage system heat traced with automatic controls, roof access security.		Update controls system narrative.
	Describe fire protection plan and systems.		Fire protection design load requirements.		Update fire protection load requirements.

Instructions: 1. Please indicate Scope of Services by marking an "X" where included as part of the project.
2. Please DO NOT DELETE the non-used Scope of Services, use the strikethrough effect instead of deleting them.
3. Add and edit the project Scope of Services as needed.

School/Building Name **Insert**
Date Prepared **Insert**

Schematic Phase		Design Development Phase		Construction Document Phase	
	Describe electrical design parameters, including, but not limited to: Lighting, power, fire alarm, telecom, intercom/clock, sound systems, access control, security, and video surveillance.		Revise narrative to match updated project requirements.		Final electrical narrative.
	Estimate new and or upgraded service size based on historical demand data from utility.		Electrical engineering load and lighting calculations and cut sheets of major components.		Update electrical engineering load and lighting calculations and cut sheets of major components.
	Define emergency and standby power requirements and systems.		Calculate emergency and standby power requirements.		Update emergency and standby power calculations.
	Define other utilities and services required.		Finalize calculations for other utilities and services.		Finalized calculations for other utilities and services. Estimate operating utility costs, including gas, electricity, water and sewer
	Describe fall protection plan and systems		Outline system and coordination with existing where applicable.		Update fall protection narrative
	Determine Special Systems, their level of performance and quality (see Narrative Note 1)				
	Describe quality control system's check list		Implement quality control checklist.		Update quality control checklist.
	Identify any existing overgrown landscaping that may affect building footprint and roof parapets,		Describe existing overgrown landscaping for the building footprint and roof parapets,		Update description.
			Color selections for all exterior and interior finishes and materials		Color selections for all exterior and interior finishes and materials
					Color board(s) for all interior and exterior finishes and materials

NARRATIVE NOTE: 1. Special Systems are computer and telecommunication systems including, but not limited to, telephone, intercom, clock, television, public address/sound, media retrieval, theatrical lighting and sound, access control and security.

SPECIFICATIONS*

* = Each successive phase includes items from the previous phase; transfer technical and design data and keynotes from Narrative to DD and CD Drawings

** = When Conceptual Master Plan Design is required, provide and update at Schematic Design phase.

(a) = See FPSA Article B4.1.1.1

	Create Table of Contents showing Technical Sections to be included, identifying major materials and systems in CSI format		Draft Technical Specifications, identifying material and system selections for each Section (CSI format)		Final Technical Specifications in hard copy and electronic format.
--	---	--	--	--	--

Instructions: 1. Please indicate Scope of Services by marking an "X" where included as part of the project.
2. Please DO NOT DELETE the non-used Scope of Services, use the strikethrough effect instead of deleting them.
3. Add and edit the project Scope of Services as needed.

School/Building Name **Insert**
Date Prepared **Insert**

Schematic Phase		Design Development Phase		Construction Document Phase	
			Review ASD standard specifications, such as door hardware, doors, windows, shades, carpet, etc and use/modify as needed for project requirements. Clearly show what changes are made to ASD standard specs and indicate why changes are recommended		Final Technical Specifications in hard copy and electronic format.
	On Table of Contents, identify all project elements having impact on ASD Divisions 0 and 1, such as demolition.		Review ASD Division 0; recommend edits to ASD Division 1 in collaboration with ASD PM.		Update edits to ASD Division 1, including Bid Form and bid strategies such as additive alternates, allowances, unit prices, etc.
			Identify testing requirements, special inspections, replacement stock, and systems requiring commissioning in ASD Division 1 – General Requirements		Update and detail.
			Draft submittal register.		Finalize submittal register.

PERFORMANCE SPECIFICATIONS AND DRAWINGS* - FIRE PROTECTION (MECHANICAL)

* = Each successive phase includes items from the previous phase; transfer technical and design data and keynotes from Narrative to DD and CD Drawings

** = When Conceptual Master Plan Design is required, provide and update at Schematic Design phase.

(a) = See FPSA Article B4.1.1.1

	Specifications: Include fire protection sections in table of contents.		Specifications: Define sprinkler design parameters including, but not limited to, wet or dry, density, conditions of freezing or excessive heat, Zones/Hazard classifications, FM global requirements and utility connections. Determine requirements for seismically bracing existing system.		Specifications: Define submittal requirements including, but not limited to, sprinkler legend, piping and head layout, pipe sizes, zone valve locations and details, riser diagram, monitoring system connections, main drains, and backflow prevention.
	Drawings: Fire protection legend.		Drawings: Fire protection legend, abbreviations and notes.		Drawings: Fire protection legend, abbreviations and notes.
	Drawings: Identify areas of wet or dry sprinkler work.		Drawings: Overall plan indicating areas of work, hazard zone and FM global requirements if applicable.		Final plans.
	Drawings: Identify water service/fire riser locations and fire pump if applicable.		Drawings: Water service entrance schematic with sprinkler riser and backflow prevention.		Final piping schematics.

Instructions: 1. Please indicate Scope of Services by marking an "X" where included as part of the project.
2. Please DO NOT DELETE the non-used Scope of Services, use the strikethrough effect instead of deleting them.
3. Add and edit the project Scope of Services as needed.

School/Building Name **Insert**
Date Prepared **Insert**

Schematic Phase	Design Development Phase	Construction Document Phase
-----------------	--------------------------	-----------------------------

DRAWINGS* - GENERAL
 * = Each successive phase includes items from the previous phase; transfer technical and design data and keynotes from Narrative to DD and CD Drawings
 ** = When Conceptual Master Plan Design is required, provide and update at Schematic Design phase.
 (a) = See FPSA Article B4.1.1.1

	Title sheet showing project title, project address, ASD project number, Design Team	Update
General notes, abbreviations, drawing and material conventions, vicinity map, drawing index, and code classification information (including occupancies, construction types, allowable and actual areas, applicable codes, etc.). Scope of work descriptions	Update. Summary scope of work per each discipline, per base bid and alternates (if any), separately.	Update
Seismic recovery scope of work includes structure and non-structure (Architectural, Mechanical, and Electrical) drawings per seismic assessment report requirements.	Seismic drawings are needs for demolitions, repairs, patches, and replacements, such as (but no limited) site, floor, ceiling, and roof plans, elevations, sections, and details to match all related different disciplines' scope below.	Update

DRAWINGS* - CIVIL
 * = Each successive phase includes items from the previous phase; transfer technical and design data and keynotes from Narrative to DD and CD Drawings
 ** = When Conceptual Master Plan Design is required, provide and update at Schematic Design phase.
 (a) = See FPSA Article B4.1.1.1

Surveyed plat including, but not limited to, legal description, property lines, easements, buffers, rights-of-way	Update	Update
Survey of existing conditions including, but not limited to, topography, hydrology, drainage, structures, roadways, vegetation, utilities, 3-dimensional control points	Update	Update
Proposed building(s) and site improvements including, but not limited to, athletic fields, waste collection and recycle holding, loading docks, bicycle racks, playground	Dimensioned locations of building(s) and site improvements off 3-D control points	Construction limits and staging area(s); Detailed building(s) and site improvements.
**Master plan phases locating future relocatable buildings		Construction phasing and coordination where applicable (See Article B6)

Instructions: 1. Please indicate Scope of Services by marking an "X" where included as part of the project.
2. Please DO NOT DELETE the non-used Scope of Services, use the strikethrough effect instead of deleting them.
3. Add and edit the project Scope of Services as needed.

School/Building Name **Insert**
Date Prepared **Insert**

Schematic Phase		Design Development Phase		Construction Document Phase	
			Preliminary grading and drainage including, but not limited to, storm water control, footing and rain leaders.		Final grading and drainage referenced to 3-D control points.
	Identify roof rain leader drainage systems and connections to the site storm water drainage system		Provide site drawings showing rain leader downspouts, drainage system, and storm water control		Final drainage referenced to 3-D control points. Details, including, but not limited to: manholes and cleanouts
	Schematic proposed utility routes and access to existing utilities		Preliminary utility layouts, details and locates referenced to 3-D control points		Final utility layouts, details and locates referenced to 3-D control points
	Vehicular and pedestrian access including, but not limited to, parking, drop-offs, bus loading, service, and off-site access		Dimensioned vehicular and pedestrian access with traffic control plan and snow storage location		Detailed vehicular and pedestrian access and traffic control referenced to 3-D control points
	Identify any required off-site improvements		Dimensioned layout of off-site improvements		Detailed off-site improvements referenced to 3-D control points
	Identify ADA-compliant accessible route(s) and parking locations		Dimensioned layout of site ADA-compliant improvements, details		ADA-compliant signage and striping
					Excavations, compactions, shoring, underpinning and retaining walls.
			Exterior lighting plans showing design foot-candles, orientation and exposure control.		Exterior lighting details

DRAWINGS* - LANDSCAPING
 * = Each successive phase includes items from the previous phase; transfer technical and design data and keynotes from Narrative to DD and CD Drawings
 ** = When Conceptual Master Plan Design is required, provide and update at Schematic Design phase.
 (a) = See FPSA Article B4.1.1.1

	Topographic base plan showing major existing and proposed site amenities and landscaping (a)		Planting plans and schedules, playgrounds and athletic fields		Soil preparations, planting and site amenities details, irrigation requirements, and protection of existing vegetation
	Identify any existing overgrown landscaping that may affect building footprint, building facia, roof and roof parapets.				

DRAWINGS* - HAZARDOUS MATERIALS ABATEMENT
 * = Each successive phase includes items from the previous phase; transfer technical and design data and keynotes from Narrative to DD and CD Drawings
 ** = When Conceptual Master Plan Design is required, provide and update at Schematic Design phase.
 (a) = See FPSA Article B4.1.1.1

Instructions: 1. Please indicate Scope of Services by marking an "X" where included as part of the project.
2. Please DO NOT DELETE the non-used Scope of Services, use the strikethrough effect instead of deleting them.
3. Add and edit the project Scope of Services as needed.

School/Building Name **Insert**
Date Prepared **Insert**

Schematic Phase		Design Development Phase		Construction Document Phase	
			Floor (roof) plans showing locations and types of hazardous materials. Including but not limited to, hazmat scope, locations, quantities and removal or abatement methods and details.		Update plans and abatement measures not covered by technical specifications
			Quantify materials removal or abatement.		Update the quantify materials removal or abatement.

DRAWINGS* - ARCHITECTURAL
 * = Each successive phase includes items from the previous phase; transfer technical and design data and keynotes from Narrative to DD and CD Drawings
 ** = When Conceptual Master Plan Design is required, provide and update at Schematic Design phase.
 (a) = See FPSA Article B4.1.1.1

	**Depictions of general building mass, its relationship to site, scale and appearance.				
	**Overall floor plans showing, as appropriate, existing to be removed and new construction, room locations and square footage; for renovations, show existing to remain and to be removed; (a)		Update. Reference enlarged plans, building sections, exterior elevations.		Update
	(Demo and New) Floor plans of typical rooms showing equipment and furnishings (a)		Update plans and enlarged typical rooms. Freeze furnishings layer. Reference vertical assemblies, wall opening types and designations, interior elevations, wall openings, equipment and casework, details.		Update
					Photographs of existing conditions showing work items
	Fire and code plans showing existing and new rated walls, paths of egress, occupant loads, separations, pertinent code classifications and designated ADA-accessible routes.		Update, showing all floor plans, including basements, mezzanines, and fan rooms.		Update. Reference typical ADA details.
			Detail vertical and horizontal assemblies showing fire ratings and approved test numbers (UL, FM, etc.)		
			Schedule finishes		Detail finishes

Instructions: 1. Please indicate Scope of Services by marking an "X" where included as part of the project.
2. Please DO NOT DELETE the non-used Scope of Services, use the strikethrough effect instead of deleting them.
3. Add and edit the project Scope of Services as needed.

School/Building Name **Insert**
Date Prepared **Insert**

Schematic Phase		Design Development Phase		Construction Document Phase	
			Schedule openings (doors, windows, relites, louvers, hatches, etc.) and hardware.		Detail openings.
			Identify and adjust the existing door closer locations on HVAC renovations		Detail
			Schedule roof sections		Update details
			Schedule equipment and casework.		Detail
			(Demo and New) Reflected ceiling plans indicating changes in ceiling to floor (or re-roof related) elevations and materials. (Enlarged plans, as necessary)		Ceiling and soffit details
	Typical representative building cross sections (a)		Complete building sections, referencing wall sections		Update
	Typical floor and wall assemblies		Typical wall sections, wall assembly R-. values, and details		Update and complete wall sections
			Typical interior elevations		Update and complete interior elevations. Details.
	(Demo and New) Roof plans (overall plan and detailed plans, as necessary) depicting roof exterior elements and objects. Includes verification of electrical raceway below deck. (a)		Roof plans to include, but not be limited to, slope, drainage, curbs, parapets, hatches , ladders, monitors and skylights, all equipment, penetrations, expansion and seismic joints, fall protection locations		Roof details. Reference on plans.
	Typical roof assemblies		Roof assembly R-values, and details		Update and complete details
			Enlarged vertical circulation plans and sections including, but not limited to, stairs, ramps and elevators		Details
			Determine and schedule required room numbering based on new construction or renovation per ASD standards		Miscellaneous details.
					1% Art, where integrated with project's permanent construction (see Article B4)

DRAWINGS* - STRUCTURAL

* = Each successive phase includes items from the previous phase; transfer technical and design data and keynotes from Narrative to DD and CD Drawings

** = When Conceptual Master Plan Design is required, provide and update at Schematic Design phase.

(a) = See FPSA Article B4.1.1.1

Project Name

Project Number **Insert Number**

RFP Number **Insert Number**

Issued 06/20/00; Revised 3-05-2020

Instructions: 1. Please indicate Scope of Services by marking an "X" where included as part of the project.
2. Please DO NOT DELETE the non-used Scope of Services, use the strikethrough effect instead of deleting them.
3. Add and edit the project Scope of Services as needed.

School/Building Name **Insert**
Date Prepared **Insert**

Schematic Phase		Design Development Phase		Construction Document Phase	
	Establish design loads; structural design to meet the current codes		Structural legend and notes, including code requirements and design criteria, special inspection requirements.		Update
	(Demo and New) Foundation structural framing plans with reference grids, systems and materials. Locate shear walls. (overall plan, as necessary)		Dimensions. Member sizes. Reference structural enlarged plans, and sections.		Reference structural details and schedules
	(Demo and New) Floor structural framing plans with reference grids, systems and materials. Locate shear walls. (overall plan, as necessary)		Dimensions. Member sizes. Reference structural enlarged plans, and sections.		Reference structural details and schedules
	(Demo and New) Roof structural framing, wind load, snow load plans with reference grids, systems and materials. Locate shear walls. (overall plan, foundation plan, as necessary)		Dimensions. Member sizes. Reference structural enlarged plans, and sections.		Reference structural details and schedules
			Dimensioned foundation plans		Reference foundation details
			Structural sections		Reference structural details
			Typical structural details		Complete and update structural details
			Typical structural schedules		Update schedules

DRAWINGS* - PLUMBING

* = Each successive phase includes items from the previous phase; transfer technical and design data and keynotes from Narrative to DD and CD Drawings

** = When Conceptual Master Plan Design is required, provide and update at Schematic Design phase.

(a) = See FPSA Article B4.1.1.1

	Plumbing legend, symbols and abbreviations		General notes		Finalize legend, symbols, abbreviations and notes.
	Plumbing schedules to include list of new fixtures and equipment.		Plumbing schedules indicating basis of design plumbing fixtures and equipment.		Final plumbing schedules.
	Plumbing site plan to identify roof rain leader connections with storm water system (drywell if any). Identify utility connections. Show meter locations.		Site plan coordinated with Civil indicating routing of sanitary sewer, domestic water, storm drain and gas piping within 5 feet of building. Site plan shall indicate cleanout locations and storm drain overflow locations,		Final site plan, coordinated with Civil site plan.

Instructions: 1. Please indicate Scope of Services by marking an "X" where included as part of the project.
2. Please DO NOT DELETE the non-used Scope of Services, use the strikethrough effect instead of deleting them.
3. Add and edit the project Scope of Services as needed.

School/Building Name **Insert**
Date Prepared **Insert**

Schematic Phase		Design Development Phase		Construction Document Phase	
	Show slab demolition for underfloor piping in remodel projects.		Underfloor piping plans with slab demolition indicated in remodel areas coordinated with architectural and structural footing and foundation plans indicated. Detail references.		Final underfloor piping plans. Slab demolition in remodel areas shall be coordinated with architectural and structural slab demolition. Final detail references.
	(Demo and New) Subfloor and floor plumbing plans, locating header(s), pipe chases, fixtures, equipment and special plumbing systems including but not limited to well systems, fire pumps, fuel oil, or compressed gas systems (propane, natural gas, air). Identify roof rain leaders and connections with storm water system (drywell if any). Show preliminary routing and sizing of main piping.		Subfloor and floor, plans showing, but not limited to domestic and waste water, rain leaders and their drainage slopes, vents, drains, cleanouts, special systems, penetrations. Enlarged plumbing plans including but not limited to toilet rooms, kitchens and mechanical rooms. Pipe labeled and sized, fixtures and equipment tagged to match schedules. Detail references.		Final subfloor and floor plans and enlarged plans with all piping sized and labeled, cleanouts and trap primer locations and access identified. Final detail references.
	(Demo and New) Roof plan showing roof drains and overflow drains.		Roof plans showing, but not limited to, roof drains, overflow drains (heat trace, if any), vents, gas piping, penetrations and curbs. Detail references.		Final Roof Plan, coordinated with Architectural roof plan. Final pipe sizes and detail references.
			Piping schematics and details for plumbing equipment. Including but not limited to water heaters, plumbing fixture risers, trap primer, vents, meters, pipe supports		Final plumbing piping schematics and details.

DRAWINGS* - HVAC

* = Each successive phase includes items from the previous phase; transfer technical and design data and keynotes from Narrative to DD and CD Drawings
 ** = When Conceptual Master Plan Design is required, provide and update at Schematic Design phase.
 (a) = See FPSA Article B4.1.1.1

	HVAC legend, symbols and abbreviations		General notes.		Finalize legend, symbols, abbreviations and notes.
	HVAC schedules to include list of equipment, including but not limited to, boilers, pumps, tanks, heat exchangers, coils, air handling equipment, terminal heating and ventilation equipment, noise reduction equipment and refrigeration equipment.		HVAC schedules indicating basis of design equipment.		Final HVAC schedules.

Instructions: 1. Please indicate Scope of Services by marking an "X" where included as part of the project.
2. Please DO NOT DELETE the non-used Scope of Services, use the strikethrough effect instead of deleting them.
3. Add and edit the project Scope of Services as needed.

School/Building Name **Insert**
Date Prepared **Insert**

Schematic Phase		Design Development Phase		Construction Document Phase	
	(Demo and New) subfloor, floor and roof plans; Show locations of existing equipment, heating piping or ductwork that is scheduled to be demolished. Show locations of new equipment and preliminary routing and sizing of main heating piping and ductwork.		Subfloor, floor and roof plans with all heating piping, ductwork and mechanical equipment. Enlarged to-scale plans, sections and elevations for mechanical rooms and/or equipment. Piping and ductwork labeled and sized, equipment tagged to match schedules. Roof plans, including but not limited to, boiler venting, roof mounted equipment, exhaust/relief hoods, air intake locations. Coordinate with Architectural reflected ceiling plans. Identify Maintenance access points. Reference details.		Final subfloor, floor, roof and enlarged plans, sections and elevations with all equipment, piping and ductwork, and access points sized, tagged, labeled and coordinated with Architectural. Final reference details.
	(Demo and New) Show locations of air intake, mixing, relief and exhaust for ventilation systems. Identify gravity return air paths. Identify special occupancy zones		Air Intake, mixing, relief and exhaust locations coordinated with building exterior elevations and sections. Coordinate package units with building systems.		Final air intake, mixing, relief and exhaust locations.
	(Demo) Piping schematics for mechanical equipment.		New piping schematics and details for mechanical equipment. Identify installation details.		Final piping schematics and details. Equipment curbs coordinated with Architectural. Final installation details.
	One line flow diagrams depicting mode of operations		One line diagrams depicting operations of various design conditions, including, but not limited to, fluid flow rates, temperature and pressures, other balancing/control information, list of operational requirements and set-points.		Control diagrams coordinated with sequence of operations.
	Demolition Drawings: Show locations of existing control panels, thermostats and sensors that are scheduled to be demolished.		Control panels identified on plans coordinated with electrical for power and data connections. New control sensors and thermostat locations identified. Coordinate with ASD BAS Contractor		Final control panel locations. Final sensor/thermostat locations and identification for associated equipment/zone.

DRAWINGS* - LIGHTING

* = Each successive phase includes items from the previous phase; transfer technical and design data and keynotes from Narrative to DD and CD Drawings
 ** = When Conceptual Master Plan Design is required, provide and update at Schematic Design phase.
 (a) = See FPSA Article B4.1.1.1

	Electrical legend		Update electrical legend		Complete electrical legend
--	-------------------	--	--------------------------	--	----------------------------

Instructions: 1. Please indicate Scope of Services by marking an "X" where included as part of the project.
2. Please DO NOT DELETE the non-used Scope of Services, use the strikethrough effect instead of deleting them.
3. Add and edit the project Scope of Services as needed.

School/Building Name **Insert**
Date Prepared **Insert**

Schematic Phase		Design Development Phase		Construction Document Phase	
	Schematic fixture schedule with general description of fixture types		Fixture schedule with all fixture types and part numbers defined.		Completed fixture schedule
	Demolition Drawings: Show locations of existing site, emergency and interior light fixtures, switches and control that are scheduled to remain or be demolished. Include roof plan as required.		Update demolition drawings and notes.		Complete demolition drawings and notes.
	Show all new lighting control field devices (switches, occupancy sensors, etc.) Include roof plan as required.		All lighting controls shown on drawings. Include roof plan as required.		Circuiting for all light fixtures and complete panel schedules.
			Lighting details showing pertinent wiring diagrams, control details, and/or installation details.		Final lighting details.
	Show site lighting plan with exterior fixtures and illumination levels required.		Site plan including, but not limited to, lighting fixtures (quantities and types), poles, emergency lighting, and light levels.		Complete site plan.
	Interior lighting plan showing fixture types, quantities and illumination level required per room/area. Show all new lighting control field devices (switches, occupancy sensors, etc.)		Floor plans including, but not limited to, lighting fixtures (quantities and types) and switching layouts, emergency lighting and light levels. All lighting controls shown on drawings. Lighting		Complete floor plan

DRAWINGS* - ELECTRICAL POWER DISTRIBUTION

* = Each successive phase includes items from the previous phase; transfer technical and design data and keynotes from Narrative to DD and CD Drawings

** = When Conceptual Master Plan Design is required, provide and update at Schematic Design phase.

(a) = See FPSA Article B4.1.1.1

	Electrical Legend		Update Electrical Legend		Complete Electrical Legend
	Power Demolition Drawings: Show locations of existing electrical equipment (panels, receptacles, etc.) that are scheduled to remain or be demolished.		Update demolition drawings and notes. Verify existing panel(s), circuit(s), and schedule. Requiring opening the panel to verify circuits are available spares, instead of relying on the as-built schedule.		Complete demolition drawings and notes
			Power load calculations		Final load calculation.
			Fault current calculation		Final fault current calculation

Instructions: 1. Please indicate Scope of Services by marking an "X" where included as part of the project.
2. Please DO NOT DELETE the non-used Scope of Services, use the strikethrough effect instead of deleting them.
3. Add and edit the project Scope of Services as needed.

School/Building Name **Insert**
Date Prepared **Insert**

Schematic Phase		Design Development Phase		Construction Document Phase	
	Electric vault location basic site electrical plan with utility transformer and service entrance equipment.		Update site plan		Complete site plan
	Show locations of new receptacles. Show locations of existing equipment requiring power.		Show all new equipment requiring power including, but not limited to, mechanical equipment, architectural equipment or owner provided equipment.		Final floor plans showing all equipment requiring power.
	Show locations of new main electrical distribution equipment and existing panels in work, including lighting.		Show all new and existing branch panels. Provide existing panel schedules. Provide blank panel schedules for all new and existing branch panels.		Circuiting for all equipment and complete panel schedules, including lighting.
	Identify and locate emergency or standby systems.		Emergency or standby load estimate		Complete emergency or standby wiring systems and final load
	Preliminary one-line diagrams, (demolition existing and new).		Revised one-line diagrams to include room numbers for panels and transformers.		Final one-line diagrams. Connection to FA, emergency or standby systems, security and HVAC. MCC details
	Locate and describe heat trace and control.		Basic details for installation including, but not limited to, heat trace control, grounding and trenching details		Complete details

DRAWINGS* - FIRE ALARM

* = Each successive phase includes items from the previous phase; transfer technical and design data and keynotes from Narrative to DD and CD Drawings
** = When Conceptual Master Plan Design is required, provide and update at Schematic Design phase.
(a) = See FPSA Article B4.1.1.1

	Connection to monitoring system		Device locations		Connection details including MCC, HVAC, elevators, door hardware, emergency or standby systems, BAS, and security.
	Fire alarm control panel location		Fire alarm panel, annunciator panel locations and proposed NAC booster/amplifier cabinets		All fire alarm control devices
	All initiating devices (pull stations and smoke detectors) All notification appliances (horn/strobes or speaker/strobes)		Update all initiating/notification device locations as design progresses. System needs calculations if more than 2 devices are added.		Final locations of all fire alarm field devices.

Instructions: 1. Please indicate Scope of Services by marking an "X" where included as part of the project.
2. Please DO NOT DELETE the non-used Scope of Services, use the strikethrough effect instead of deleting them.
3. Add and edit the project Scope of Services as needed.

School/Building Name **Insert**
Date Prepared **Insert**

Schematic Phase		Design Development Phase		Construction Document Phase	
Fire alarm code summary.					
DRAWINGS* - SPECIAL SYSTEMS (computer and telecommunication systems including, but not limited to, telephone, intercom, clock, television, public address/ sound, media retrieval, theatrical lighting and sound, access control and security) * = Each successive phase includes items from the previous phase; transfer technical and design data and keynotes from Narrative to DD and CD Drawings ** = When Conceptual Master Plan Design is required, provide and update at Schematic Design phase. (a) = See FPSA Article B4.1.1.1					
Show locations of existing and new telecom rooms.		Layout of equipment in rooms. Indicate tie-in locations. Rack elevations, telecom backbone details. Note information for ventilation requirements.		Show backboard layout and connections, and ventilation	
Provide notes and plans for demolition coordination. Special systems demolition drawings.		Update special systems demolition drawings.		Final special systems demolition drawings.	
Show locations of existing and new head-end equipment for telephone, intercom, clock, television, public address/ sound, media retrieval, theatrical lighting and sound, access control and security. Locate and verify security sensor for roof access door or hatch.		Plans showing types and layouts of Special Systems, including backbone, cable trays and roof security. Identify equipment placement and device locations.		Detail connections	
Typical classroom layout for all special systems - show for one classroom.		Show device locations in all classrooms.		Final locations of all special systems devices	
All systems' device layout in all other rooms and areas.		Update all systems' device locations in all other rooms and areas including, but not limited to, corridors, MPR, gym and toilet.		Final all systems' device locations in all other rooms and areas.	
Preliminary one-line diagrams (demolition and new)		Full one-line diagrams for all special systems.		Final one-line diagrams for all special systems.	

COST ESTIMATES*
 * = Each successive phase includes items from the previous phase; transfer technical and design data and keynotes from Narrative to DD and CD Drawings
 ** = When Conceptual Master Plan Design is required, provide and update at Schematic Design phase.
 (a) = See FPSA Article B4.1.1.1

Instructions: 1. Please indicate Scope of Services by marking an "X" where included as part of the project.
2. Please DO NOT DELETE the non-used Scope of Services, use the strikethrough effect instead of deleting them.
3. Add and edit the project Scope of Services as needed.

School/Building Name **Insert**
Date Prepared **Insert**

Schematic Phase		Design Development Phase		Construction Document Phase	
	Provide Estimated Total Construction Cost		Provide Estimated Total Construction Cost, including bid strategies such as additive alternates, allowances, unit prices, etc. at 65% CD completion.		Provide Estimated Total Construction Cost, including bid strategies such as additive alternates, allowances, unit prices, etc. at 95% CD completion.
BID AND POST-BID SERVICES: CONSTRUCTION DOCUMENTS (Drawings and Specifications)					
	Bid Phase		Post-Bid/Pre-Construction Period		Construction Phase
	Addenda, including attached drawings and specifications		Conformed Construction Documents (see sections B3.5 and B5.5)		Supplementary Drawings in hardcopy and electronic format
POST-CONSTRUCTION SERVICE: (Drawings, Specifications and Reports)					
					Post-Construction Phase
					Project Record Documents – Includes record drawings, specifications and related documents. See Specification Section 01720 "Project Record Documents" for requirements, and PM to provide Project Record Checklist. Provide "Roof Section Schedule" in PDF and digital files if it does not include in construction documents.
					Provide the Hazmat Response Action Report base on the AHERA manuals requirements.

Contract No:
Date Prepared:

ANCHORAGE SCHOOL DISTRICT
FORMAL PROFESSIONAL SERVICES AGREEMENT

C1.1 Payments will be made based on invoices that are approved by the Anchorage School District and any applicable funding agency. To acquire approval of an invoice, the Contractor must submit the invoice in accordance with Article A5 of this Agreement and the following indicated (by checked box) schedule, which schedule is set forth in its entirety in the FPSA C Price Schedule pages 3 and 4. Regardless of the payment schedule agreed upon by the parties, payment shall be limited to the maximum allowable amount(s) stated herein. Provisions for audit are contained in Article A7 of this Agreement.

C2.1 The Contractor shall not be paid any markup of costs under this Agreement, except as allowed by provision C10.1 for the following:

C3.1 The Contractor has no right to any payment in excess of the maximum amount payable as stated in this Appendix, unless an Amendment providing for such increased payment has been executed by both parties and approved (if required) by the Anchorage School Board.

C4.1 Final payment to the Contractor may be withheld until the Contractor submits a fully-executed release of all claims under this Agreement, on a form(s) prescribed by the Anchorage School District.

C5.1 The Anchorage School District's List of Standard Definitions of Terms and Allowances for Costs is contained in this FPSA C Basis of Compensation. Any word or phrase defined on pages 1-4 shall be interpreted to have the meaning stated therein whenever such word or phrase appears in Appendix C and regardless whether such word or phrase is capitalized as it appears in the list of definitions.

LIST OF STANDARD DEFINITIONS OF TERMS AND ALLOWANCES FOR COSTS

C6.1 Cost Objective - A function, organizational subdivision, contract or work unit for which cost data are accumulated.

C7.1 Markup - A percentage of incurred expenses for specified direct costs which may be used as a basis of compensation for specified indirect costs (e.g., payroll benefits or overhead), or profit, or both.

Project Name
Project Number Insert Number
RFP Number Insert Number
Revised 4-18-18

Basis of Compensation
Appendix C

- C8.1 Direct Cost - A specific cost identified with a single cost objective. Direct costs are segregated into two categories: direct salary costs and direct non-salary costs.
- C8.2 Direct Salary Costs - The sum of actual compensation paid to all employees regardless of job classification when such employees are directly engaged in services necessary to fulfill the terms of this Agreement.
- C8.2.1 The rates of pay for assignable productive time of principals and salaried personnel shall be commensurate with that which would be paid a hired professional with the qualifications necessary to perform the tasks assigned.
- C8.2.2 Overtime costs, if approved by the Project Manager, are direct salary costs.
- C8.3 Non-Direct Salary Costs – All items of expense directly incurred by, or attributable to, a specific project, assignment or task, such as:
- C8.3.1 Fees paid for securing approval of regulatory authorities having jurisdiction over the Project. (Such fees may be paid directly by the Anchorage School District if requested by the Contractor, in which event no markup will be paid);
- C8.3.2 Communications;
- C8.3.3 Duplication of reports, drawings and specifications. Also included are duplication costs for revised submittals that were required by the Anchorage School District's changes in scope of the Project. (Duplication costs relating to revised submittals necessitated by Contractor's inadequacies are excluded);
- C8.3.4 If specifically identified in this Agreement or, if authorized in writing by the Project Manager, actual costs of the following items: Subcontracts; transportation (economy rates/air-coach); per diem (Anchorage School District schedule and rates); incidental travel expenses, computer use at specified rates; equipment use at specified rates; specific materials and supplies; and other direct non-salary costs.
- C9.1 Indirect Costs - Costs not directly identified with a single cost objective, but identified with two or more cost objectives. Indirect costs consist of expenses which, because of their incurrence for common or joint cost objectives must be prorated (allocated) to jobs or contracts using a specified markup based on incurred direct costs. Generally, indirect costs are segregated into two categories: payroll benefits and overhead.
- C9.2 Payroll Benefits may include costs of items such as: vacation time and authorized leave; group and workers' compensation insurance; deferred compensation/retirement plans; social security and unemployment taxes; and group medical plan and life insurance premiums.
- C9.2.1 Any markup for payroll benefits shall be derived as follows: The sum of actual and allowable costs for payroll burden during a base period (usually a fiscal year) divided by the sum of direct salary costs during the same period, expressed as a percentage.
- C9.3 Overhead may include the following general and administrative (G&A) items, if they are not included in direct costs: general office administrative and supervisory wages; travel, food, lodging; communications; duplication costs; computer costs; business insurance premiums not billed to clients; office supplies; rent, heat, power, light, janitorial services; upkeep and depreciation of office equipment; rentals of equipment; and recruiting expenses.
- C9.3.1 The following costs are generally not included as overhead: interest and other financial costs; bad debts; contributions and donations; fines and penalties; losses on other contracts; entertainment; contingencies; dividends; and income taxes.

C9.3.2 In determining individual items of cost which may be included as overhead, the following factors are considered:

Allocability - Cost is chargeable to one or more cost objectives, and it benefits the Agreement and is necessary to the overall operation of the business;

Reasonableness - Cost does not exceed that which would be incurred by an ordinarily prudent person in the conduct of competitive business;

Standards promulgated by the Federal Cost Accounting Standards Board; and

If this Agreement is supported by federal funds, Title 41, Parts 1-15, Code of Federal Regulations (CFR). (If a military funding agency, the Defense Acquisition Regulations [DAR] supersede the CFR.)

C9.3.3 Any markup for overhead shall be derived as follows: The sums of actual and allowable indirect costs during a base period (usually a fiscal year), divided by the sum of direct salary costs during the same period, expressed as a percentage.

C9.4 Compensation for indirect costs may be based upon separate markups for payroll benefits and overhead, or upon one markup which includes both factors. Markup(s), if used under the terms of this Agreement, may be subject to audit verification in accordance with Appendix A, Article A7.

C10.1 Negotiated Markup for Specific Cost Objective, or Profit, or Both - A negotiated markup is a markup other than a markup for indirect costs in accordance with provision C9.2.1 or C9.3.3. Most, if not all, costs incurred for administration and management of Subcontracts and other direct non-salary costs are generally compensated as part of the payment received for direct salary costs or markups for indirect costs. Therefore, compensation based on a negotiated markup will not be allowed under this Agreement, unless the specific expenses or profit represented by such markup are fully identified and the School District is satisfied, in its sole discretion, that compensation for such expenses or profit has not been included within compensation for direct salary or indirect costs.

PRICE SCHEDULE

C.11.1 Contractor will be paid by the method(s) checked below and at the fixed rates specified for personnel time or other unit of measurement. Such rates include all profit and costs, except for any direct non-salary costs allowed by provision C14.1, which may be payable in addition to fixed rate costs. Payments shall not exceed allowances as may be stated below. (NOTE: Schedules attached to this appendix shall list actual unit prices and/or billing rates which include all costs, and are not subject to markup for indirect costs or profit. Any conditions of such schedules which conflict with the Anchorage School District's standard conditions as contained herein shall be void.)

MAXIMUM ALLOWANCE FOR PHASE, TASK OR WORK PRODUCT	\$
MAXIMUM ALLOWANCE FOR TIME AND MATERIALS	\$
MAXIMUM ALLOWANCE FOR DIRECT NON-SALARY COSTS	\$
MAXIMUM AMOUNT PAYABLE	\$

C12.1 Progress Payments for Phase/Tasks/Work Products Completed

Progress payments will be made based on approved invoices which shall segregate costs for each phase, task or work product listed below or in attached schedules. The sum of payments for

Project Name
Project Number **Insert Number**
RFP Number **Insert Number**
Revised 4-18-18

Basis of Compensation
Appendix C

each phase, task or work product shall not exceed an amount equal to the fixed price multiplied by the percentage (as determined by the Anchorage School District) of the phase, task or work product completed, plus the sum of any reimbursements for direct non-salary costs.

<u>PHASE/TASK/WORK PRODUCT</u>	<u>DATE TO BE COMPLETED</u>	<u>FIXED PRICE</u>
SUBTOTAL-FIXED PRICES:		
ALLOWANCE FOR DIRECT NON-SALARY COSTS:		
MAXIMUM AMOUNT PAYABLE:		

C.13.1 Time and Materials Not to Exceed

Progress payments, equal to the number(s) of hours expended by each named individual or job classification multiplied by the applicable hourly billing rates in attached schedules, will be made based on approved invoices which shall fully substantiate the number of hours expended.

C14.1 Direct Non-Salary Costs

Payments for direct non-salary costs are limited by provisions C8.3 and C8.3.1 - C8.3.4. Additionally, the Contractor is hereby authorized reimbursement for the specific items listed below at the rates specified below or in attached schedules, or if not specified, of actual costs. Other items may be authorized in accordance with provision C8.3.4. Payments, to include any applicable markup if specified in provision C2.1, will be made based on approved invoices which shall fully substantiate costs.

Contract No:
Date Prepared:

ANCHORAGE SCHOOL DISTRICT
FORMAL PROFESSIONAL SERVICES AGREEMENT

ARTICLE D1 Indemnification

D1.1 To the fullest extent permitted by law, the Contractor shall indemnify and hold harmless, the Anchorage School District and the Municipality of Anchorage (hereafter in this provision D1.1 collectively referred to as "Anchorage School District") from and against any and all actual or alleged claims, actions, demands, or liabilities, damages, financial losses, costs or expenses, including reasonable attorney's fees, arising out of one or more negligent acts or failures to act by the Contractor which relate to this Agreement. The Contractor shall not be required to indemnify or hold harmless the Anchorage School District against an actual or alleged claim, action, demand, liability, damages, financial loss, cost or expense arising out of the Independent Act or Failure to Act of the Anchorage School District. If there is a claim, action, demand, liability, damages, financial loss, cost or expense arising out of the joint act or failure to act of the Contractor and Independent Act or Failure to Act of the Anchorage School District, this indemnification and hold harmless obligation shall be apportioned on a comparative fault basis. The term "Independent Act or Failure to Act" as used herein means an act or failure to act by the Anchorage School District other than the following: The selection of Contractor, the administration of the Agreement, the observation of the Contractor's services performed or work product produced under the Agreement; the review, approval or acceptance of the Contractor's services or work product; the observation of the Contractor's administration of the Construction Contract; or the observation of the Contractor's observation of the Construction Contractor's Work under the Construction Contract.

ARTICLE D2 Insurance

D2.1 The Contractor shall purchase at its own expense and maintain in force at all times for the duration of the Agreement, plus two years following the date of final payment, the policies of insurance identified in provisions D2.1.1 - D2.1.5. Where specific limits are identified below, the Contractor acknowledges that those limits are the minimum acceptable limits. If a policy contains higher limits and broader coverage, the Anchorage School District shall be entitled to the higher limits and broader coverage. Certificates of insurance must be furnished to the Anchorage School District and incorporated into the Agreement with copies attached to this Appendix D. All certificates must provide for a 30-day prior written notice to the Anchorage School District of cancellation or reduction in any limits of liability. Failure to furnish certificates of insurance or lapse of a policy is a material breach of this Agreement and grounds for termination of the Contractor's services, and may preclude other agreements between the Contractor and the Anchorage School District. The Contractor shall require and verify that all subcontractors meet the insurance requirements as stated in D2 Insurance.

D2.1.1 Workers' Compensation Insurance: For all employees of the Contractor engaged in providing services under this Agreement, Workers' Compensation Insurance as required by AS 23.30.045 or the statutes of other states in which Contractor's employees are working, or both. \$1,000,000 Each Accident Limit/\$1,000,000 Disease Policy Limit/ \$1,000,000 Disease Each Employee. Contractor shall also provide Employer's Liability Insurance in an amount not less than \$1,000,000. Where applicable, the Contractor shall provide the insurance coverage required by all federal law (e.g., U.S.L. & H. and Jones Acts/\$1,000,000 Maritime Limit).

Project Name
Project Number **Insert Number**
RFP Number **Insert Number**
Revised 4-18-18

Indemnification and Insurance
Appendix D

D2.1.2 Commercial General Liability Insurance: Such insurance shall cover all operations by, or on behalf of, the Contractor and provide insurance for bodily injury and property damage liability, including coverage for premises and operations products and completed operations, contractual liability, broad form property damage, and personal injury liability. The minimum limit of liability required is \$1,000,000 per occurrence, \$2,000,000 aggregate for bodily injury and property damage and \$1,000,000 personal and advertising injury.

D2.1.3 Commercial Automobile Liability Insurance: Such insurance shall cover all owned, hired and non-owned, uninsured/underinsured, with coverage limits not less than \$1,000,000 combined single limit for bodily injury and property damage per accident.

D2.1.4 Professional Liability Insurance: Covering all negligent errors or omissions which the Contractor, subcontractor or anyone directly or indirectly employed by them, make in the performance of this Agreement which result in financial loss to the Anchorage School District. The Contractor shall require provisions of this Article in all first tier Subcontracts of land surveyor, architectural, and civil, structural, mechanical, and electrical professional Subcontractors so as to be binding on all such first tier Subcontractors. Minimum limits required are per the following schedule:

<u>Maximum Amount Of Agreement</u>	<u>Combined Per Claim & Annual Aggregate</u>
\$0 to \$999,999	\$1,000,000
\$1,000,000 and Over	Negotiable

COVERAGE FOR THIS AGREEMENT: \$X,XXX,XXX

D2.1.5 Umbrella/Excess Liability Limits of \$1,000,000 **(higher limits when required depending on size of contract size)** Occurrence \$1,000,000 and \$1,000,000 Aggregate over primary liability policies: Commercial General Liability, Commercial Auto and Employers Liability

D2.1.6 General Insurance Requirements: Certificates of Insurance must include the following statements:

- A. All policies, except Professional Liability and Workers' Compensation, have been endorsed to add the Anchorage School District and the Municipality of Anchorage as Additional Insureds, Commercial General Liability to include products and completed operations. The Contractors/subcontractors insurance is Primary and Non-Contributory and Anchorage School District and Municipality of Anchorage policies are considered as excess.
- B. All policies, except Professional Liability, have been endorsed to waive the insurer and insured's right of subrogation against the Anchorage School District and Municipality of Anchorage.
- C. Provide the Contracting Officer, Anchorage School District, with at least thirty (30) days written notice of any material change, cancellation or non-renewal of the policy(s) during the Contract period. Certificate of Liability Insurance shall be current ACORD 25-S form, referencing Anchorage School District project number and "description", and name Certificate Holder as:

Anchorage School District
Capital Planning & Construction
1301 Labar Street
Anchorage, AK 99515

ARTICLE D3 Modification of Insurance Requirements

D3.1 If the provisions of Article D2 are modified for this Agreement, written justification and approval by the Anchorage School District, Capital Planning & Construction and written approval by the Contractor are required in the spaces indicated below. Check the appropriate box below and complete the following, if applicable.

MODIFICATION NOT APPLICABLE:

MODIFICATION APPROVED:

<p>IDENTIFY AND JUSTIFY MODIFICATIONS.</p> <p>Continue on Additional Sheets as necessary and attach to this Appendix D.</p> <p style="text-align: center; font-size: 2em;">NOT APPLICABLE</p>
--

MODIFICATION(S) APPROVED:

**ANCHORAGE SCHOOL DISTRICT
CAPITAL PLANNING & CONSTRUCTION**

NOT APPLICABLE, NO MODIFICATIONS

Signature ASD Representative

_____ Date

CONTRACTOR

NOT APPLICABLE, NO MODIFICATIONS

Signature, Contractor

_____ Date

Name: _____

Firm: _____

Title: _____

Contract No:
Date Prepared:

ANCHORAGE SCHOOL DISTRICT
FORMAL PROFESSIONAL SERVICES AGREEMENT

ARTICLE E1

- E1.1 Contractor shall perform all professional services required under this Agreement through its own staff members, or through the Subcontractor(s) listed below in provision E1.3, or as may be allowed in accordance with Appendix A, Article A14.

- E1.2 If one or more individual members of Contractor's staff are listed below, such staff member(s) shall perform or supervise the performance of services required hereunder in the position identified, and such staff member(s) shall not be replaced or substituted unless the Contractor receives written approval thereof from the Project Manager.

<u>Staff Member</u>	<u>Position</u>
---------------------	-----------------

- E1.3 If one or more Subcontractors or individual staff members of a Subcontractor, or both, are listed below, such Subcontractor(s) or individual staff member(s) of the Subcontractor shall perform or supervise the performance of services required hereunder in the position identified, and such Subcontractor(s) or staff member(s) shall not be replaced or substituted unless the Contractor receives written approval thereof from the Project Manager.

<u>Service/Engineering Discipline</u>	<u>% Total Services</u>	<u>Subcontractor</u>	<u>AK Business License No.</u>
---------------------------------------	-------------------------	----------------------	--------------------------------

<u>Staff Member</u>	<u>Position</u>	<u>Subcontractor</u>
---------------------	-----------------	----------------------

Project Name
Project Number Insert Number
RFP Number Insert Number
Revised 4-18-18

Contract No:
Date Prepared:

ANCHORAGE SCHOOL DISTRICT
FORMAL PROFESSIONAL SERVICES AGREEMENT

- F1.1 Time is of the essence of each and every provision of this Agreement for which a specific time period is set forth for the performance of any act, duty or obligation.
- F2.1 The parties may modify this Master Time Schedule in accordance with and under the conditions set forth in Article A6 ("Changes to the Agreement").
- F3.1 Attached or below is the time schedule, current as of the last date of signature by the parties, and according to which the Contractor has agreed to provide the specified services, as well as the critical dates by which certain identified tasks are to be performed.

CONTRACTOR:

By: _____
Its: Principal
Date: _____

ANCHORAGE SCHOOL DISTRICT

By: _____
Its: Project Manager
Date: _____

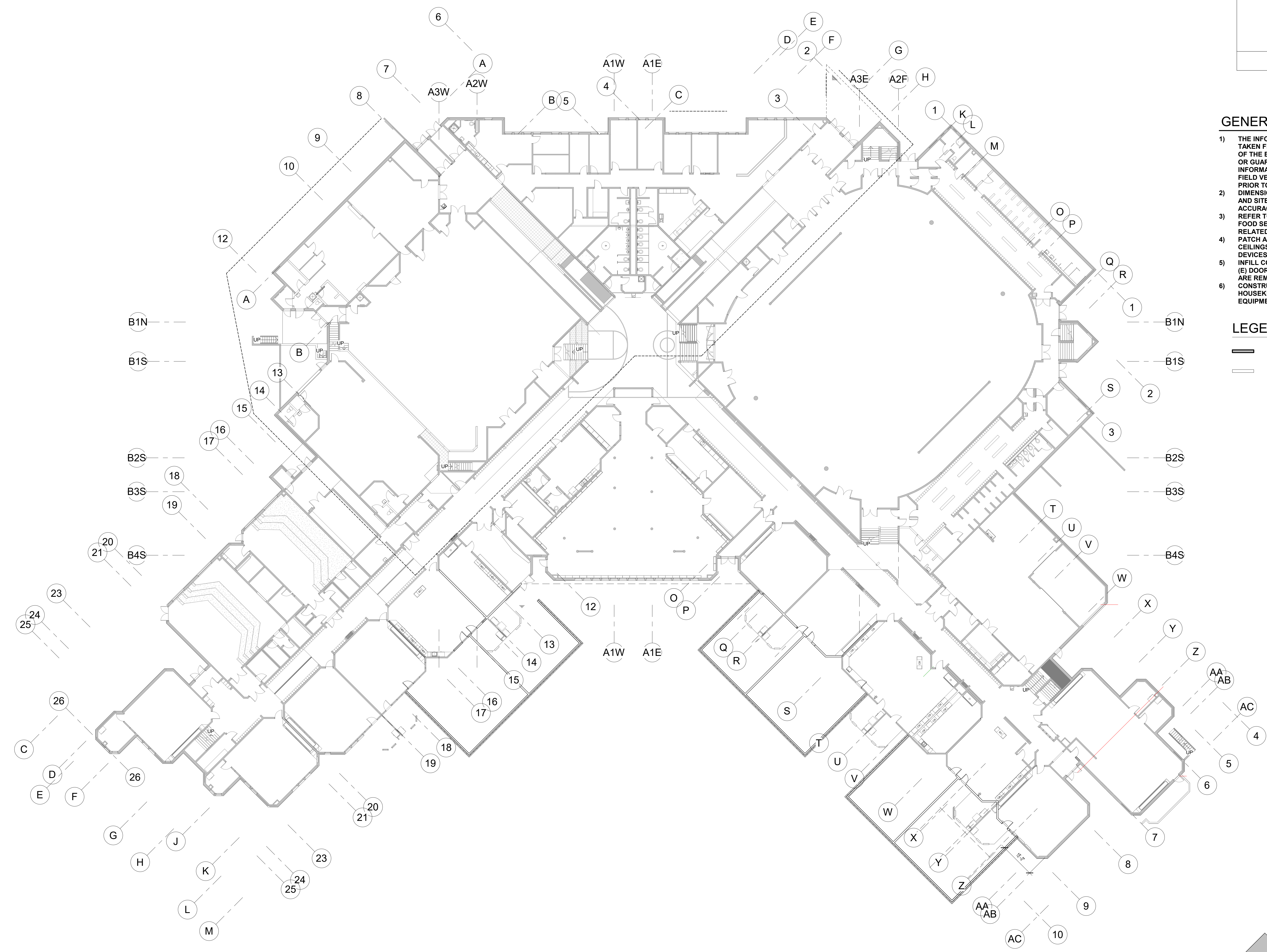

PERMIT STAMP

GENERAL NOTES - REMODEL

- 1) THE INFORMATION SHOWN IN THIS DRAWING IS TAKEN FROM AS-BUILT DRAWINGS AND WALK-THRU OF THE EXISTING FACILITY. THERE IS NO WARRANTY OR GUARANTEE OF THE ACCURACY OF THE INFORMATION SHOWN. THE CONTRACTOR SHALL FIELD VERIFY ALL ITEMS, AREAS, AND ASSEMBLIES PRIOR TO START OF WORK
- 2) DIMENSIONS ARE BASED ON AS-BUILT DRAWINGS AND SITE VISITS. CONTRACTOR TO VERIFY ACCURACY OF CRITICAL DIMENSIONS
- 3) REFER TO STRUCTURAL, MECHANICAL, ELECTRICAL, FOOD SERVICE, LANDSCAPE AND CIVIL SHEETS FOR RELATED REMODEL SCOPE
- 4) PATCH AND PAINT TO MATCH ADJACENT WALLS AND CEILINGS WHERE (E) FIXTURES, FITTINGS AND DEVICES ARE REMOVED, TYP.
- 5) INFILL CONSTRUCTION TO MATCH ADJACENT WHERE (E) DOORS, WINDOWS, DUCTS, PIPES AND CONDUITS ARE REMOVED; TYP.
- 6) CONSTRUCT NEW EQUIPMENT CURBS AND HOUSEKEEPING PADS AS REQUIRED AT NEW EQUIPMENT

LEGEND

- EXISTING PARTITION TO REMAIN
- NEW WALL

2 FLOOR PLAN - LEVEL 1 - OVERALL
A210 1/16" = 1'-0"

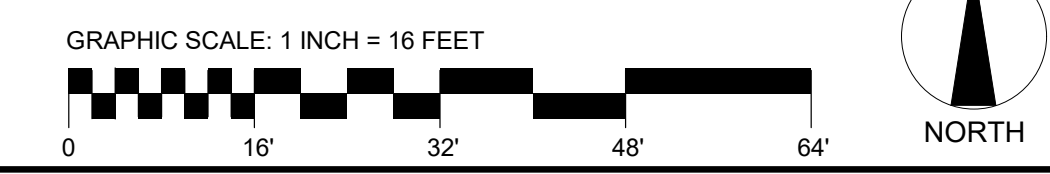

NOTIFICATION OF POTENTIAL HAZARDS:
Asbestos, lead, and other hazardous materials are present in the building and may impact the work of all trades. Regulated air contaminants, including asbestos and lead, are also present in settled and concealed dust in and on Architectural, Structural, Mechanical, and Electrical components or systems throughout the building. All trades shall coordinate with other trades and conduct their work to prevent worker exposure or site contamination. Refer to Specification Divisions 0, 1, and 2 for specific information concerning disturbing, removing, and disposing of these materials and the installation of new materials or components. This notification is provided in accordance with EPA and OSHA requirements.

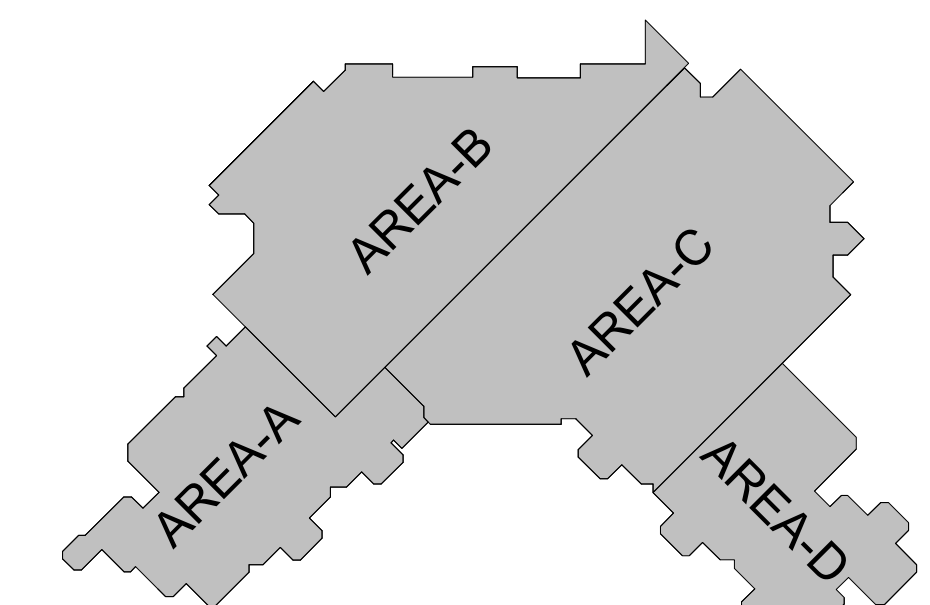

KEY PLAN - NOT TO SCALE

RECORD DOCUMENTS

RECORD DOCUMENT

MC COOL CARLSON GREEN
ARCHITECTURE • PLANNING • INTERIORS
HISTORIC ANCHORAGE TRAIN DEPOT
421 W. 1ST AVENUE • SUITE 300 • ANCHORAGE, AK 99501
907.563.8474 PHONE • 907.563.4572 FAX • WWW.MCGALASKA.COM

GRUENING MIDDLE SCHOOL EARTHQUAKE RECOVERY
ANCHORAGE SCHOOL DISTRICT
9601 Lee St, Eagle River, AK 99577



REMODEL REFERENCE PLAN - LEVEL 1

SHEET NO. **A210**

REVISIONS:

PROJ. NO. 2018021	CHECKER
PROJ. MGR. GFB	
DRAWN BY: ABW	
DATE: 10/12/23	

LEGEND

-  EXISTING PARTITION TO REMAIN
-  NEW WALL

PERMIT STAMP

GENERAL NOTES - REMODEL

- 1) THE INFORMATION SHOWN IN THIS DRAWING IS TAKEN FROM AS-BUILT DRAWINGS AND WALK-THRU OF THE EXISTING FACILITY. THERE IS NO WARRANTY OR GUARANTEE OF THE ACCURACY OF THE INFORMATION SHOWN. THE CONTRACTOR SHALL FIELD VERIFY ALL ITEMS, AREAS, AND ASSEMBLIES PRIOR TO START OF WORK.
- 2) DIMENSIONS ARE BASED ON AS-BUILT DRAWINGS AND SITE VISITS. CONTRACTOR TO VERIFY ACCURACY OF CRITICAL DIMENSIONS.
- 3) REFER TO STRUCTURAL, MECHANICAL, ELECTRICAL, FOOD SERVICE, LANDSCAPE AND CIVIL SHEETS FOR RELATED REMODEL SCOPE.
- 4) PATCH AND PAINT TO MATCH ADJACENT WALLS AND CEILINGS WHERE (E) FIXTURES, FITTINGS AND DEVICES ARE REMOVED; TYP.
- 5) INFILL CONSTRUCTION TO MATCH ADJACENT WHERE (E) DOORS, WINDOWS, DUCTS, PIPES AND CONDUITS ARE REMOVED; TYP.
- 6) CONSTRUCT NEW EQUIPMENT CURBS AND HOUSEKEEPING PADS AS REQUIRED AT NEW EQUIPMENT.

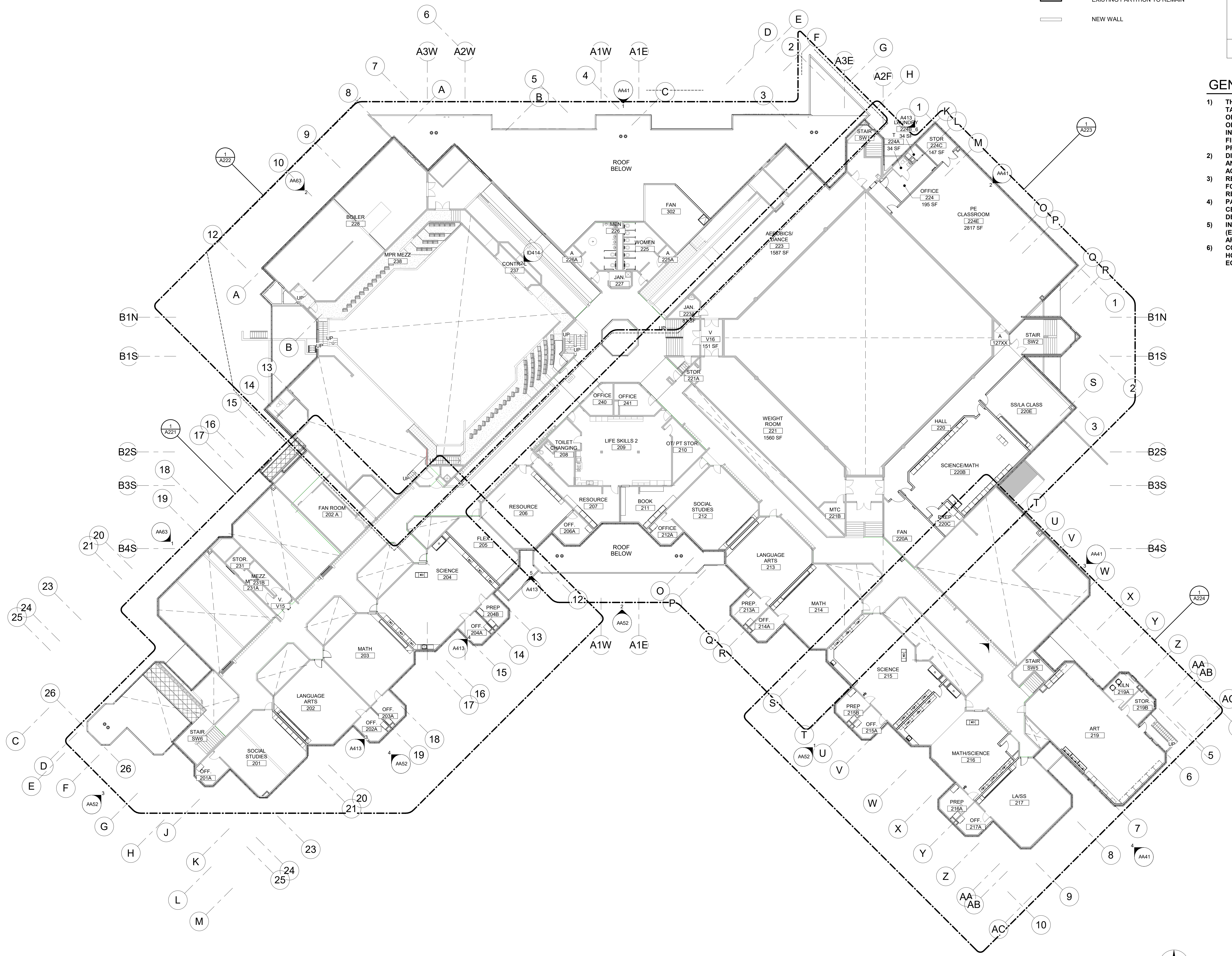

1 FLOOR PLAN - LEVEL 2 - OVERALL
A220 1/16" = 1'-0"

NOTIFICATION OF POTENTIAL HAZARDS:

Asbestos, lead, and other hazardous materials are present in the building and may impact the work of all trades. Regulated air contaminants, including asbestos and lead, are also present in settled and concealed dust in and on Architectural, Structural, Mechanical, and Electrical components or systems throughout the building. All trades shall coordinate with other trades and conduct their work to prevent worker exposure or site contamination. Refer to Specification Divisions 0, 1, and 2 for specific information concerning disturbing, removing, and disposing of these materials and the installation of new materials or components. This notification is provided in accordance with EPA and OSHA requirements.

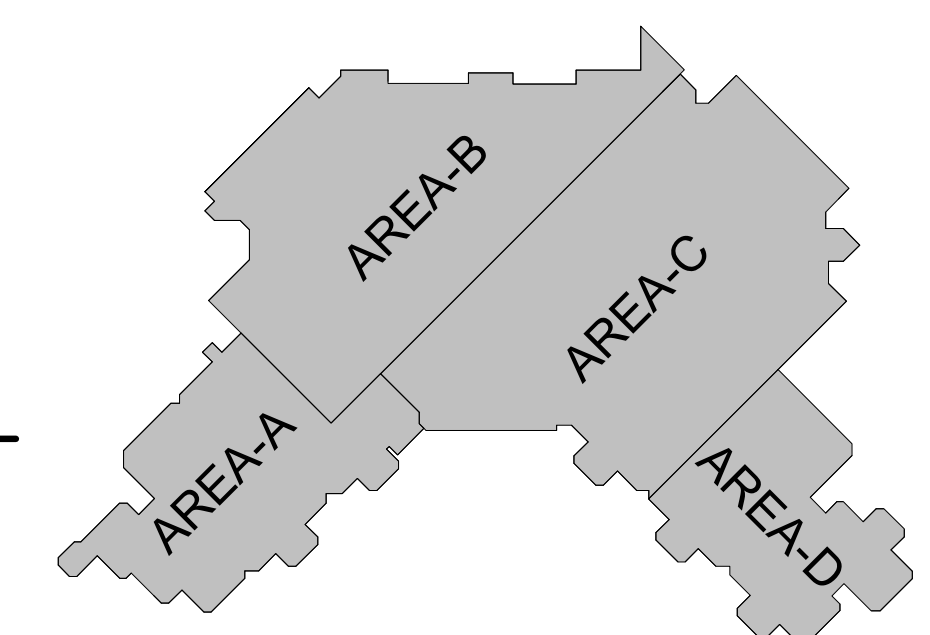
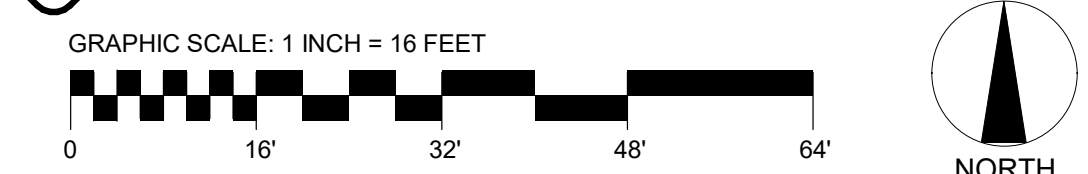

KEY PLAN - NOT TO SCALE





REVIEWED BY:	Checked
PROJ. MGR. / P/B	
DRAWN BY: ABW	
DATE: 10/12/23	
REVISIONS:	

RECORD DOCUMENT
MCCOOL CARLSON GREEN
 ARCHITECTURE + PLANNING • INTERIORS
 HISTORIC ANCHORAGE TRAIN DEPOT
 421 W. 1ST AVENUE • SUITE 300 • ANCHORAGE, AK 99501
 907.563.8474 PHONE • 907.563.4572 FAX • WWW.MCGALASKA.COM

RECORD DOCUMENTS
GRUENING MIDDLE SCHOOL EARTHQUAKE RECOVERY
 ANCHORAGE SCHOOL DISTRICT
 9601 Lee St, Eagle River, AK 99577
REMODEL REFERENCE PLAN - LEVEL 2

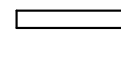
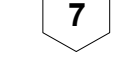
SHEET NO.
A220

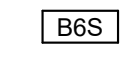
LEGEND

-  EXISTING WALL TO REMAIN
-  NEW WALL
-  KEY NOTE TAG
-  KEY NOTE TAG FOR FEMA REIMBURSABLE SCOPE OF WORK; REFER TO A070 FOR MORE INFORMATION
-  WALL TYPE TAG, REFER TO SHEET A060
-  WINDOW TYPE TAG, REFER TO SHEET A713



GENERAL NOTES - REMODEL

- 1) THE INFORMATION SHOWN IN THIS DRAWING IS TAKEN FROM AS-BUILT DRAWINGS AND WALK-THRU OF THE EXISTING FACILITY. THERE IS NO WARRANTY OR GUARANTEE OF THE ACCURACY OF THE INFORMATION SHOWN. THE CONTRACTOR SHALL FIELD VERIFY ALL ITEMS, AREAS, AND ASSEMBLIES PRIOR TO START OF WORK
- 2) DIMENSIONS ARE BASED ON AS-BUILT DRAWINGS AND SITE VISITS. CONTRACTOR TO VERIFY ACCURACY OF CRITICAL DIMENSIONS
- 3) REFER TO STRUCTURAL, MECHANICAL, ELECTRICAL, FOOD SERVICE, LANDSCAPE AND CIVIL SHEETS FOR RELATED REMODEL SCOPE
- 4) PATCH AND PAINT TO MATCH ADJACENT WALLS AND CEILINGS WHERE (E) FIXTURES, FITTINGS AND DEVICES ARE REMOVED, TYP.
- 5) INFILL CONSTRUCTION TO MATCH ADJACENT WHERE (E) DOORS, WINDOWS, DUCTS, PIPES AND CONDUITS ARE REMOVED; TYP.
- 6) CONSTRUCT NEW EQUIPMENT CURBS AND HOUSEKEEPING PADS AS REQUIRED AT NEW EQUIPMENT

KEY NOTES

7	NEW ROOF CANOPY CONSTRUCTION
31	INSTALL EXTERIOR SIDING, WINDOWS AND DOORS; REPLACING ALL EXISTING
32	REPLACE FLOORING IN CLASSROOMS, CIRCULATION AND OTHER AREAS TYP. UNO
33	REPAINT INTERIORS
59	INSTALL NEW FLOOR AND WALL TILE, TOILET PARTITIONS, PLUMBING FIXTURES AND TOILET ACCESSORIES; SCOPE WITH ALTERNATE NO. 6
75	INSTALL SALVAGED SIDE-OPENING ACCORDIAN SECURITY GRILLE; VERIFY OPERATION AND REPAIR AS REQUIRED
FM508	EARTHQUAKE MITIGATION: REFINISH FIBER REINFORCED CMU SHEAR WALLS; REFER TO STRUCTURAL PLANS FOR EXTENTS
FR501	EARTHQUAKE REPAIR: REPOINT/REPAIR CMU AND PAINT - INTERIOR
FR503	EARTHQUAKE REPAIR: REPAIR GYPSUM WALLBOARD (GWB) CRACKS THROUGHOUT THE BUILDING AND PAINT AFFECTED WALL
FR509	EARTHQUAKE REPAIR: REPLACE/REINSTALL MISSING CEILING FABRIC WRAPPED ACOUSTIC PANELS
FR523	EARTHQUAKE REPAIR: REPLACE FAILED CMU RAILING WITH CMU BOND BEAM AND REPLACE AFFECTED STEEL PIPE GUARDRAIL SECTION

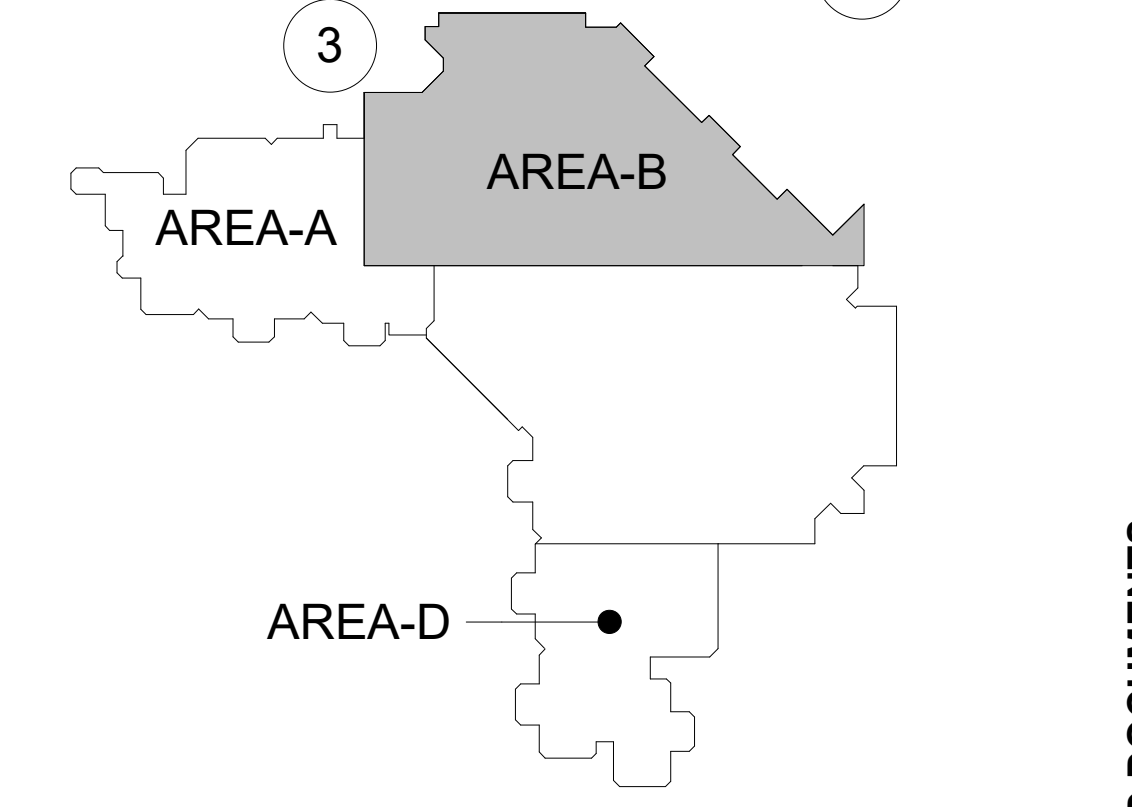
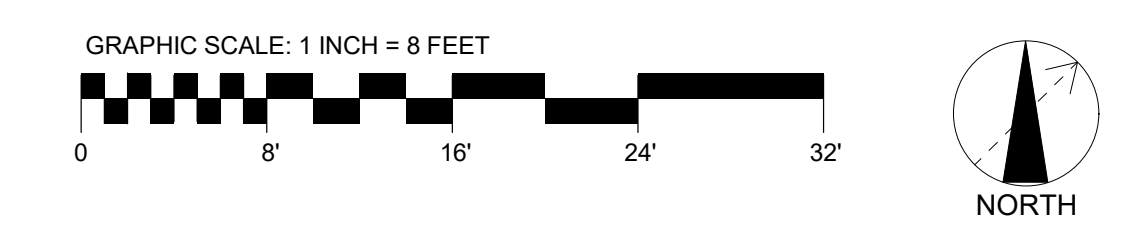
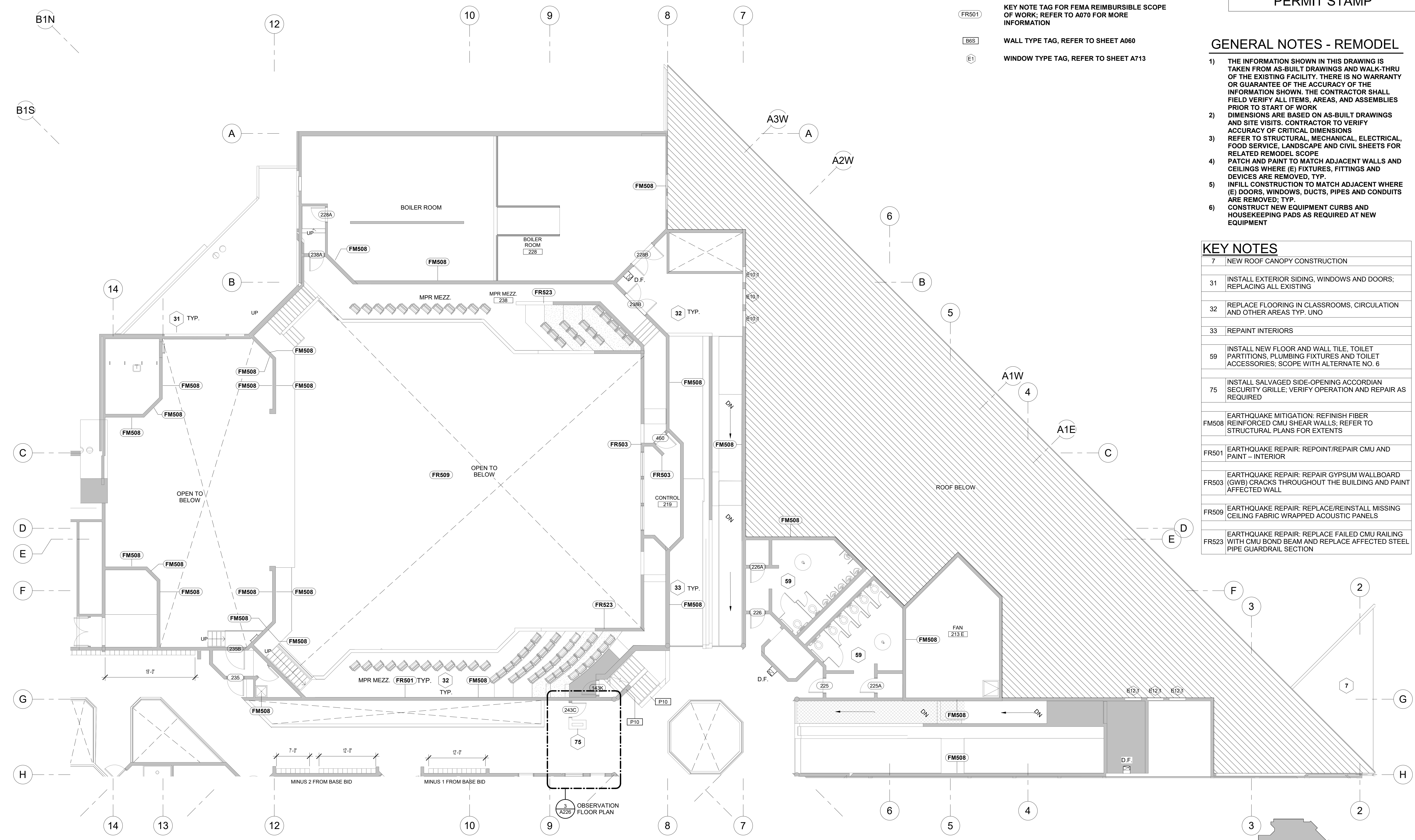

1 FLOOR PLAN - LEVEL 2 - AREA B
 A222 1/8" = 1'-0"

NOTIFICATION OF POTENTIAL HAZARDS:
 Asbestos, lead, and other hazardous materials are present in the building and may impact the work of all trades. Regulated air contaminants, including asbestos and lead, are also present in settled and concealed dust in and on Architectural, Structural, Mechanical, and Electrical components or systems throughout the building. All trades shall coordinate with other trades and conduct their work to prevent worker exposure or site contamination. Refer to Specification Divisions 0, 1, and 2 for specific information concerning disturbing, removing, and disposing of these materials and the installation of new materials or components. This notification is provided in accordance with EPA and OSHA requirements.

RECORD DOCUMENT
MC COOL CARLSON GREEN
 ARCHITECTURE + PLANNING • INTERIORS
 HISTORIC ANCHORAGE TRAIN DEPOT
 421 W. 1ST AVENUE • SUITE 300 • ANCHORAGE, AK 99501
 907.563.8474 PHONE • 907.563.4572 FAX • WWW.MCGALASKA.COM

SHEET NO.
A222

GRUENING MIDDLE SCHOOL DISTRICT
 ANCHORAGE SCHOOL DISTRICT
 9601 Lee St, Eagle River, AK 99577
REMODEL FLOOR PLAN - LEVEL 2 - AREA B

DESIGNER: GRUENING MIDDLE SCHOOL DISTRICT
 PROJECT NO.: 2018021
 DRAWN BY: ABW
 DATE: 10/12/2023
 CHECKER:



Anchorage School District

Gruening Middle School Mechanical Upgrades

Prepared For:

Anchorage School District
 Facilities Department
 1301 Labar Street
 Anchorage, AK, 99515

Prepared By:

RSA Engineering
 670 W Fireweed, STE 200
 Anchorage, AK, 99503

December 7, 2023

Existing Conditions

The existing boilers serving the school are dual fuel, Burnham PF-514's with dual fuel power flame burners. The burners were upgraded to dual fuel under a 2008 project; the boilers are from the original construction of the facility (~1983). In recent years frequent maintenance repairs have been necessary, resulting in no more than two boilers operating at any given time.

Several other upgrades are included, which have been found to be necessary through feedback from the teachers and administrators.

Facility upgrades

Mechanical Room

The existing boilers and day tanks will be demolished, along with their associated stacks and controls. The existing boiler circulation pumps will remain, they were replaced under the 2020 upgrades to the facility. The replacement heating plant will be comprised of (2) Aerco Boilers sized at 60% of the design heating load, as well as (2) dual fuel cast iron boilers. The air separator and expansion tank serving the boiler system will be demolished and replaced. Motorized valves will be provided on each boiler to ensure heating water flows through the equipment during operation. A pot feeder and filter will be installed on the boiler system for water treatment and debris removal.

Housekeeping pads will be poured for each boiler, anticipated height is 6" to encase the existing rails recessed in the mechanical room floor for the existing boilers.

The existing boiler stacks will be replaced with AL29-4C products, as required by the boiler manufacturers. The replacement equipment will utilize the (3) curbs for the existing boilers.

The existing boiler emergency stop will be demolished and replaced with a model that is connected to shunt trip breakers for each boiler.

The contractor will be required to repair any pipe braces or remnant hangers within the mechanical room. It is estimated that 100 hangers within the mechanical room need repaired/removed/replaced.

The boiler room perimeter will be curbed while the heating equipment is out of the room. A self-leveling mixture will be poured throughout the mechanical room to seal any holes in the floor and ensure that all leaks drain to one of the nearby floor drains. Where piping penetrates the floor or equipment is anchored to the floor, a 1" lip will be provided to prevent any leaks at floor penetrations.

The existing hot water generators, tempering valve, and circulation pump will be demolished. Replacement water heating equipment for the facility will be comprised of (2) Aerco Smart plates and (1) 215 gallon hot water storage tank. The replacement tempering valve will be a 2" model electronic Aerco model.

The boilers and additional appurtenances will be integrated into the existing Siemens DDC system for the school.

Piping at the water meter will be replaced where noticeable corrosion is present. Replacement piping will be flanged copper.

December 7, 2023

Gas piping throughout the boiler room will be re-supported, and have bracing inspected/ upgraded to current code requirements.

The gas meter may be required to be upgraded by the Gas Utility. This will be coordinated as the design progresses.

Classroom 101 Heating

In classroom 101 and Office 101A, approximately 25 feet of 3-row fin tube will be installed. This will be connected to the existing ¾-inch branch lines under the staircase. The piping will run behind the classroom's casework before leading into the fin tube enclosure. The fin tube will be integrated into the Direct Digital Control (DDC) system and controlled via the existing space-mounted sensor.

Electrical work in the room will be required to relocate existing junction boxes out of the fin tube installation area.

Band/Orchestra Noise Transmission

To mitigate sound transmission through the return air ductwork, the existing grilles in each space will be removed. Additional ductwork equipped with sound attenuators will be designed to prevent disturbances in adjacent classrooms.

Rough duct sketches for each location are provided in the attached appendix documents.

Classroom 160 & 163

In each classroom the supply air grilles (qty of 6) will be replaced with adjustable blade models for redirecting air flow.

At the return air grille locations for the ductwork will be modified to better control noise through the grilles, and between classrooms. A chase will be constructed of 2x4 studs to enclose the corner and associated sheet metal. All electrical junction boxes and outlets in the area will be extended to the face of the wall.

See accompanying sketches for ductwork/chase configuration.

December 7, 2023

Equipment List

Boilers – Condensing – (2) BMK 4000's

Boilers – Dual Fuel – (2) De Dietrich GT530A-

Day Tank – Simplex STS300

Pot Feeder/Filter – Axiom CBF-5

Water Heaters – (2)Aerco Smartplate EV30, 17 gal of 140F water continuous.

Water Storage Tank – Aerco SSST215

TV-1 – Aerco ADMS 2.0" Single

Band Silencer – Price CS12x36 Code E, 1100 CFM @ 0.15" SP

Orchestra Silencer – Price CS12x36 Code E, 1100 CFM @ 0.15" SP

Classroom 101 Fintube – Zehnder Rittling IBG5

Supply Grilles – Krueger Model 480 w/ Adjustable Blades parallel to long dimension

Return Grilles – Price Model 10

December 7, 2023

Photos



FIGURE 1. EXISTING BOILER ROOM



FIGURE 2. EXISTING BOILER SIZE



FIGURE 3. WATER SERVICE PIPING TO BE REPLACED

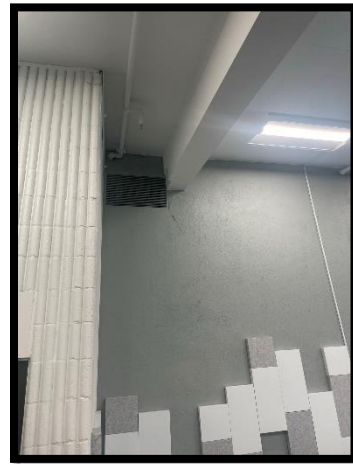

FIGURE 4. BAND RETURN GRILLE.

December 7, 2023



FIGURE 5. ORCHESTRA RETURN GRILLE



FIGURE 6. CLASSROOM 160 DUCT TO BE RECONFIGURED



FIGURE 7. CLASSROOM 101 FIN TUBE LOCATION

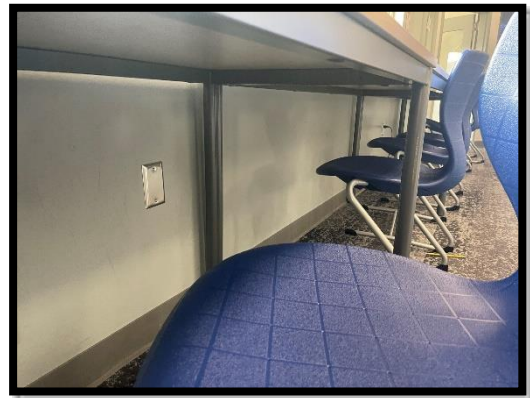

FIGURE 8. CLASSROOM 101 RECEPTACLES TO BE RELOCATED.

The logo for Reid Middleton, featuring the name in a bold, white, sans-serif font on a dark blue rectangular background.

CIVIL ENGINEERING
STRUCTURAL ENGINEERING
SURVEYING
PLANNING

GRUENING MIDDLE SCHOOL – BOILER ROOM BEAM REPLACEMENT & UPGRADES

Eagle River, Alaska

RM Project #402023.136

Structural Calculations
November 27, 2023

By: Ellen Hamel, SE
Reid Middleton, Inc.
Corporate License AECC598
4300 B Street, Suite #302
Anchorage, AK 99503
Office: (907) 562-3439
Fax: (907) 561-5319

Copyright © 2023 by Reid Middleton, Inc. All rights reserved.

ALASKA | CALIFORNIA | WASHINGTON

4300 B Street, Suite 302, Anchorage, AK 99503 | 907 562-3439 | www.reidmiddleton.com

Gruening Middle School Boiler Room Beam Replacement
 402023.136

EH
 10/21/2023

New Beam Design

Mechanical loading

	pipe size (diam, in)	qty	trib l (ft)	wgt/ft (plf)	total w (lb)	
pvc	2	6	10	2.2	132	includes water weight
pvc	1	1	10	0.726	7.26	includes water weight
pvc	3	2	10	4.7	94	includes water weight
electrical	1	7	10	1.61	112.7	
electrical	0.5	16	10	0.82	131.2	
pvc	1.5	2	10	1.45	29	includes water weight
duct	18	1	10	10	100	
heating water	12	1	10	102	1020	includes water weight
					<u>P =</u>	<u>1626.16 lb</u>

span = 32 ft
 $M = PL/4 = 13.0$ kft

for reference, $M_{dead + snow} = 154$ kft
 $M_{dead} = 29.8$ kft

Dead load

DL = 15 psf

Snow load

Flat roof = 40 psf
 Unbalanced load = 25 psf
 total S = 65 psf

per 2019 dwg sheet S007

See Enercalc for new beam design

New W beam reactions:

$D + S = 20.6$ k (from Enercalc)

S =	16.12 k
D =	4.5 k
	<u>20.7 k</u>

Adhesive anchor solution is not adequate, use thru bolts

CMU bearing stress per TMS, 8.1.5
bearing stress shall not exceed 0.33 f'm
Abr per Section 4.3.4
lesser of $A1 \sqrt{A2 / A1}$ and $2 A1$
bolt diam = 1 in
A1 = loaded area = 7.63 sq in
A2 per section 4.3.4 = 7.63 sq in
Abr = 7.6 sq in
no. bolt = 6
bearing = 450.27 psi
f'm = 1800.0 psi, min 1980 dwgs sheet S-1
0.33 f'm = 594.0
DCR = 0.76

bolt capacity = 10.60 kips for 1" diam bolt (A307)
total capacity = 63.60 k
DCR = 0.32

Joist reactions for new hangers:

span = 15.5 ft
trib = 2 ft
 $R_{D+S} = 1240$ lb

Simpson HUS210, capacity = 4685 lb (100)
DCR = 0.26

Wind uplift

C&C = 72 psf per 2019 dwg sheet S006
 $0.6D + 0.6W = -34.2$ psf
R = -530.1 lb

Simpson HUS210, capacity = 2265 lb (160)
DCR = 0.23

Steel Beam

Project File: 23-11-01_Gruening Boiler Rm Beam_ah.ec6

LIC#: KW-06017697, Build:20.23.10.31

REID MIDDLETON, INC.

(c) ENERCALC INC 1983-2023

DESCRIPTION: New Boiler Room Beam

CODE REFERENCES

Calculations per AISC 360-16, IBC 2018, CBC 2019, ASCE 7-16
 Load Combination Set : IBC 2021

Material Properties

Analysis Method : Allowable Strength Design
 Beam Bracing : Beam is Fully Braced against lateral-torsional buckling
 Bending Axis : Major Axis Bending
 Fy : Steel Yield : 50.0 ksi
 E : Modulus : 29,000.0 ksi

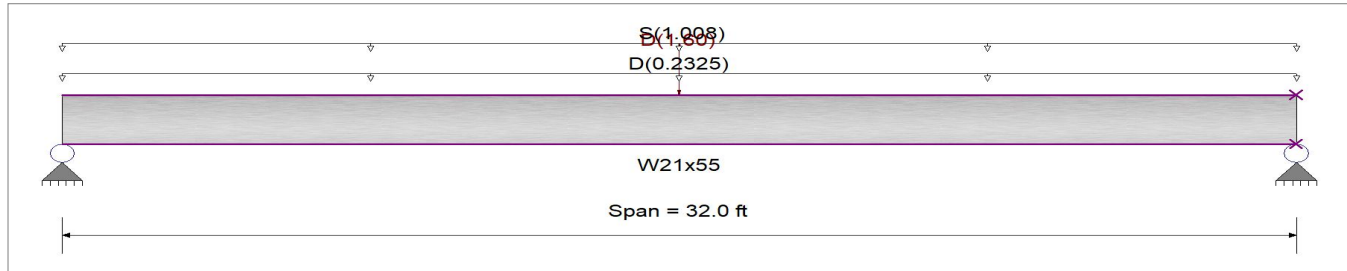

Applied Loads

Service loads entered. Load Factors will be applied for calculations.

Beam self weight NOT internally calculated and added
 Load(s) for Span Number 1
 Point Load : D = 1.60 k @ 16.0 ft, (Mech Loads)

Uniform Load : D = 0.0150 ksf, Tributary Width = 15.50 ft

Uniform Load : S = 0.0650 ksf, Tributary Width = 15.50 ft

DESIGN SUMMARY

Design OK

Maximum Bending Stress Ratio =	0.546 : 1	Maximum Shear Stress Ratio =	0.132 : 1
Section used for this span	W21x55	Section used for this span	W21x55
Ma : Applied	171.520 k-ft	Va : Applied	20.640 k
Mn / Omega : Allowable	314.371 k-ft	Vn/Omega : Allowable	156.0 k
Load Combination	+D+S	Load Combination	+D+S
Span # where maximum occurs	Span # 1	Location of maximum on span	0.000 ft
Span # where maximum occurs	Span # 1	Span # where maximum occurs	Span # 1
Maximum Deflection			
Max Downward Transient Deflection	0.722 in Ratio =	531 >=240.	Span: 1 : S Only
Max Upward Transient Deflection	0 in Ratio =	0 <240.0	n/a
Max Downward Total Deflection	0.946 in Ratio =	406 >=180.	Span: 1 : +D+S
Max Upward Total Deflection	0 in Ratio =	0 <180.0	n/a

Maximum Forces & Stresses for Load Combinations

Load Combination	Segment Length	Span #	Max Stress Ratios		Summary of Moment Values						Summary of Shear Values			
			M	V	Mmax +	Mmax -	Ma Max	Mnx	Mnx/Omega	Cb	Rm	Va Max	Vnx/Vnx/Omega	
D Only	Dsgn. L = 32.00 ft	1	0.135	0.029	42.56		42.56	525.00	314.37	1.00	1.00	4.52	234.00	156.00
+D+S	Dsgn. L = 32.00 ft	1	0.546	0.132	171.52		171.52	525.00	314.37	1.00	1.00	20.64	234.00	156.00
+D+0.750S	Dsgn. L = 32.00 ft	1	0.443	0.106	139.28		139.28	525.00	314.37	1.00	1.00	16.61	234.00	156.00
+0.60D	Dsgn. L = 32.00 ft	1	0.081	0.017	25.54		25.54	525.00	314.37	1.00	1.00	2.71	234.00	156.00

Overall Maximum Deflections

Load Combination	Span	Max. "-" Defl	Location in Span	Load Combination	Max. "+" Defl	Location in Span
+D+S	1	0.9463	16.091		0.0000	0.000

Vertical Reactions

Support notation : Far left is #

Values in KIPS

Load Combination	Support 1	Support 2
Max Upward from all Load Conditions	20.640	20.640

Project Title: [Gruening MS Boiler Room - New Beam](#)
 Engineer: [EH](#)
 Project ID: [402023.136](#)
 Project Descr: [New Beam design](#)

Steel Beam

Project File: 23-11-01_Gruening Boiler Rm Beam_ah.ec6

LIC#: KW-06017697, Build:20.23.10.31

REID MIDDLETON, INC.

(c) ENERCALC INC 1983-2023

DESCRIPTION: [New Boiler Room Beam](#)

Vertical Reactions

Support notation : Far left is #

Values in KIPS

Load Combination	Support 1	Support 2
Max Upward from Load Combinations	20.640	20.640
Max Upward from Load Cases	16.120	16.120
D Only	4.520	4.520
+D+S	20.640	20.640
+D+0.750S	16.610	16.610
+0.60D	2.712	2.712
S Only	16.120	16.120

Steel Beam

Project File: 23-11-01_Gruening Boiler Rm Beam_ah.ec6

LIC#: KW-06017697, Build:20.23.10.31

REID MIDDLETON, INC.

(c) ENERCALC INC 1983-2023

DESCRIPTION: New Boiler Room Beam WIND

CODE REFERENCES

Calculations per AISC 360-16, IBC 2018, CBC 2019, ASCE 7-16
 Load Combination Set : IBC 2021

Material Properties

Analysis Method : Allowable Strength Design
 Beam Bracing : Beam bracing is defined as a set spacing over all spans
 Bending Axis : Major Axis Bending
 Fy : Steel Yield : 50.0 ksi
 E : Modulus : 29,000.0 ksi

Unbraced Lengths

First Brace starts at 2.0 ft from Left-Most support
 Regular spacing of lateral supports on length of beam = 2.0 ft

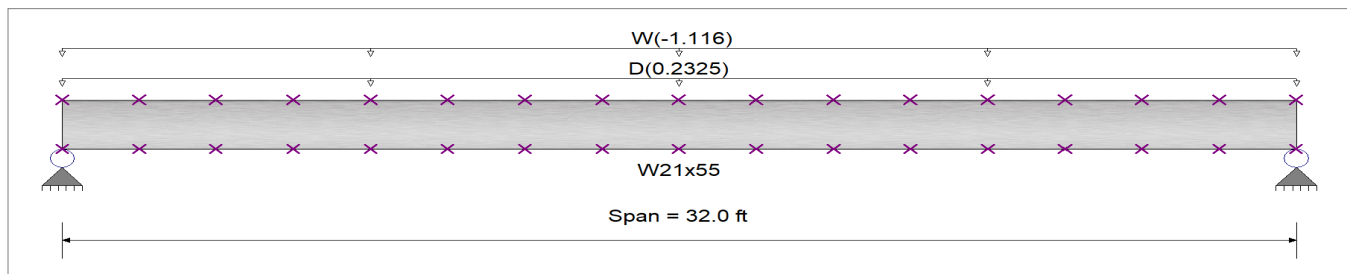

Applied Loads

Service loads entered. Load Factors will be applied for calculations.

Beam self weight NOT internally calculated and added
 Uniform Load : D = 0.0150 ksf, Tributary Width = 15.50 ft, (dead load)

Uniform Load : W = -0.0720 ksf, Tributary Width = 15.50 ft, (WIND)

DESIGN SUMMARY

Design OK

Maximum Bending Stress Ratio =	0.216 : 1	Maximum Shear Stress Ratio =	0.054 : 1
Section used for this span	W21x55	Section used for this span	W21x55
Ma : Applied	67.853 k-ft	Va : Applied	8.482 k
Mn / Omega : Allowable	314.371 k-ft	Vn/Omega : Allowable	156.0 k
Load Combination	+0.60D+0.60W	Load Combination	+0.60D+0.60W
Span # where maximum occurs	Span # 1	Location of maximum on span	0.000 ft
		Span # where maximum occurs	Span # 1
Maximum Deflection			
Max Downward Transient Deflection	0 in Ratio = 0	<240.0	n/a
Max Upward Transient Deflection	-0.800 in Ratio = 479	>=240.	Span: 1 : W Only
Max Downward Total Deflection	0.167 in Ratio = 2304	>=180.	Span: 1 : D Only
Max Upward Total Deflection	-0.380 in Ratio = 1010	>=180.	Span: 1 : +0.60D+0.60W

Maximum Forces & Stresses for Load Combinations

Load Combination	Segment Length	Span #	Max Stress Ratios		Summary of Moment Values					Summary of Shear Values				
			M	V	Mmax +	Mmax -	Ma Max	Mnx	Mnx/Omega	Cb	Rm	Va Max	Vnx/Vnx/Omega	
D Only														
Dsgn. L =	1.92 ft	1	0.021	0.024	6.71		6.71	525.00	314.37	1.69	1.00	3.72	234.00	156.00
Dsgn. L =	2.01 ft	1	0.041	0.021	12.83	6.71	12.83	525.00	314.37	1.23	1.00	3.27	234.00	156.00
Dsgn. L =	2.01 ft	1	0.057	0.018	18.00	12.83	18.00	525.00	314.37	1.13	1.00	2.81	234.00	156.00
Dsgn. L =	2.01 ft	1	0.071	0.015	22.23	18.00	22.23	525.00	314.37	1.08	1.00	2.34	234.00	156.00
Dsgn. L =	2.01 ft	1	0.081	0.012	25.53	22.23	25.53	525.00	314.37	1.05	1.00	1.87	234.00	156.00
Dsgn. L =	2.01 ft	1	0.089	0.009	27.88	25.53	27.88	525.00	314.37	1.03	1.00	1.40	234.00	156.00
Dsgn. L =	2.01 ft	1	0.093	0.006	29.29	27.88	29.29	525.00	314.37	1.02	1.00	0.94	234.00	156.00
Dsgn. L =	2.01 ft	1	0.095	0.003	29.76	29.29	29.76	525.00	314.37	1.00	1.00	0.47	234.00	156.00
Dsgn. L =	1.92 ft	1	0.095	0.003	29.76	29.33	29.76	525.00	314.37	1.00	1.00	0.45	234.00	156.00
Dsgn. L =	2.01 ft	1	0.093	0.006	29.33	27.96	29.33	525.00	314.37	1.02	1.00	0.91	234.00	156.00
Dsgn. L =	2.01 ft	1	0.089	0.009	27.96	25.65	27.96	525.00	314.37	1.03	1.00	1.38	234.00	156.00
Dsgn. L =	2.01 ft	1	0.082	0.012	25.65	22.40	25.65	525.00	314.37	1.05	1.00	1.85	234.00	156.00
Dsgn. L =	2.01 ft	1	0.071	0.015	22.40	18.21	22.40	525.00	314.37	1.07	1.00	2.32	234.00	156.00
Dsgn. L =	2.01 ft	1	0.058	0.018	18.21	13.08	18.21	525.00	314.37	1.12	1.00	2.78	234.00	156.00
Dsgn. L =	2.01 ft	1	0.042	0.021	13.08	7.01	13.08	525.00	314.37	1.21	1.00	3.25	234.00	156.00

Project Title: Gruening MS Boiler Room - New Beam
 Engineer: EH
 Project ID: 402023.136
 Project Descr: New Beam design

Steel Beam

Project File: 23-11-01_Gruening Boiler Rm Beam_eh.ec6

LIC# : KW-06017697, Build:20.23.10.31

REID MIDDLETON, INC.

(c) ENERCALC INC 1983-2023

DESCRIPTION: New Boiler Room Beam WIND

Maximum Forces & Stresses for Load Combinations

Load Combination	Segment Length	Span #	Max Stress Ratios		Summary of Moment Values						Summary of Shear Values			
			M	V	Mmax +	Mmax -	Ma Max	Mnx	Mnx/Omega	Cb	Rm	Va Max	Vnx/Vnx/Omega	
Dsgn. L = 2.01 ft	1	1	0.022	0.024	7.01		7.01	525.00	314.37	1.61	1.00	3.72	234.00	156.00
+D+0.60W														
Dsgn. L = 1.92 ft	1	1	0.040	0.045		-12.62	12.62	525.00	314.37	1.00	1.00	6.99	234.00	156.00
Dsgn. L = 2.01 ft	1	1	0.077	0.039	-0.00	-24.12	24.12	525.00	314.37	1.23	1.00	6.15	234.00	156.00
Dsgn. L = 2.01 ft	1	1	0.108	0.034	-0.00	-33.84	33.84	525.00	314.37	1.13	1.00	5.28	234.00	156.00
Dsgn. L = 2.01 ft	1	1	0.133	0.028	-0.00	-41.80	41.80	525.00	314.37	1.08	1.00	4.40	234.00	156.00
Dsgn. L = 2.01 ft	1	1	0.153	0.023	-0.00	-47.99	47.99	525.00	314.37	1.05	1.00	3.52	234.00	156.00
Dsgn. L = 2.01 ft	1	1	0.167	0.017	-0.00	-52.41	52.41	525.00	314.37	1.03	1.00	2.64	234.00	156.00
Dsgn. L = 2.01 ft	1	1	0.175	0.011	-0.00	-55.06	55.06	525.00	314.37	1.02	1.00	1.76	234.00	156.00
Dsgn. L = 2.01 ft	1	1	0.178	0.006	-0.00	-55.95	55.95	525.00	314.37	1.00	1.00	0.88	234.00	156.00
Dsgn. L = 1.92 ft	1	1	0.178	0.005	-0.00	-55.95	55.95	525.00	314.37	1.00	1.00	0.84	234.00	156.00
Dsgn. L = 2.01 ft	1	1	0.175	0.011	-0.00	-55.14	55.14	525.00	314.37	1.02	1.00	1.72	234.00	156.00
Dsgn. L = 2.01 ft	1	1	0.167	0.017	-0.00	-52.57	52.57	525.00	314.37	1.03	1.00	2.60	234.00	156.00
Dsgn. L = 2.01 ft	1	1	0.153	0.022	-0.00	-48.23	48.23	525.00	314.37	1.05	1.00	3.48	234.00	156.00
Dsgn. L = 2.01 ft	1	1	0.134	0.028	-0.00	-42.12	42.12	525.00	314.37	1.07	1.00	4.36	234.00	156.00
Dsgn. L = 2.01 ft	1	1	0.109	0.034	-0.00	-34.24	34.24	525.00	314.37	1.12	1.00	5.24	234.00	156.00
Dsgn. L = 2.01 ft	1	1	0.078	0.039	-0.00	-24.60	24.60	525.00	314.37	1.21	1.00	6.11	234.00	156.00
Dsgn. L = 2.01 ft	1	1	0.042	0.045		-13.18	13.18	525.00	314.37	1.00	1.00	6.99	234.00	156.00
+D+0.450W														
Dsgn. L = 1.92 ft	1	1	0.025	0.028		-7.79	7.79	525.00	314.37	1.00	1.00	4.32	234.00	156.00
Dsgn. L = 2.01 ft	1	1	0.047	0.024	-0.00	-14.88	14.88	525.00	314.37	1.23	1.00	3.80	234.00	156.00
Dsgn. L = 2.01 ft	1	1	0.066	0.021	-0.00	-20.88	20.88	525.00	314.37	1.13	1.00	3.25	234.00	156.00
Dsgn. L = 2.01 ft	1	1	0.082	0.017	-0.00	-25.79	25.79	525.00	314.37	1.08	1.00	2.71	234.00	156.00
Dsgn. L = 2.01 ft	1	1	0.094	0.014	-0.00	-29.61	29.61	525.00	314.37	1.05	1.00	2.17	234.00	156.00
Dsgn. L = 2.01 ft	1	1	0.103	0.010	-0.00	-32.34	32.34	525.00	314.37	1.03	1.00	1.63	234.00	156.00
Dsgn. L = 2.01 ft	1	1	0.108	0.007	-0.00	-33.98	33.98	525.00	314.37	1.02	1.00	1.08	234.00	156.00
Dsgn. L = 2.01 ft	1	1	0.110	0.003	-0.00	-34.52	34.52	525.00	314.37	1.00	1.00	0.54	234.00	156.00
Dsgn. L = 1.92 ft	1	1	0.110	0.003	-0.00	-34.52	34.52	525.00	314.37	1.00	1.00	0.52	234.00	156.00
Dsgn. L = 2.01 ft	1	1	0.108	0.007	-0.00	-34.02	34.02	525.00	314.37	1.02	1.00	1.06	234.00	156.00
Dsgn. L = 2.01 ft	1	1	0.103	0.010	-0.00	-32.44	32.44	525.00	314.37	1.03	1.00	1.60	234.00	156.00
Dsgn. L = 2.01 ft	1	1	0.095	0.014	-0.00	-29.76	29.76	525.00	314.37	1.05	1.00	2.15	234.00	156.00
Dsgn. L = 2.01 ft	1	1	0.083	0.017	-0.00	-25.99	25.99	525.00	314.37	1.07	1.00	2.69	234.00	156.00
Dsgn. L = 2.01 ft	1	1	0.067	0.021	-0.00	-21.13	21.13	525.00	314.37	1.12	1.00	3.23	234.00	156.00
Dsgn. L = 2.01 ft	1	1	0.048	0.024	-0.00	-15.18	15.18	525.00	314.37	1.21	1.00	3.77	234.00	156.00
Dsgn. L = 2.01 ft	1	1	0.026	0.028		-8.13	8.13	525.00	314.37	1.00	1.00	4.32	234.00	156.00
+0.60D+0.60W														
Dsgn. L = 1.92 ft	1	1	0.049	0.054		-15.31	15.31	525.00	314.37	1.00	1.00	8.48	234.00	156.00
Dsgn. L = 2.01 ft	1	1	0.093	0.048	-0.00	-29.25	29.25	525.00	314.37	1.23	1.00	7.46	234.00	156.00
Dsgn. L = 2.01 ft	1	1	0.131	0.041	-0.00	-41.04	41.04	525.00	314.37	1.13	1.00	6.40	234.00	156.00
Dsgn. L = 2.01 ft	1	1	0.161	0.034	-0.00	-50.70	50.70	525.00	314.37	1.08	1.00	5.33	234.00	156.00
Dsgn. L = 2.01 ft	1	1	0.185	0.027	-0.00	-58.20	58.20	525.00	314.37	1.05	1.00	4.27	234.00	156.00
Dsgn. L = 2.01 ft	1	1	0.202	0.021	-0.00	-63.56	63.56	525.00	314.37	1.03	1.00	3.20	234.00	156.00
Dsgn. L = 2.01 ft	1	1	0.212	0.014	-0.00	-66.78	66.78	525.00	314.37	1.02	1.00	2.13	234.00	156.00
Dsgn. L = 2.01 ft	1	1	0.216	0.007	-0.00	-67.85	67.85	525.00	314.37	1.00	1.00	1.07	234.00	156.00
Dsgn. L = 1.92 ft	1	1	0.216	0.007	-0.00	-67.85	67.85	525.00	314.37	1.00	1.00	1.02	234.00	156.00
Dsgn. L = 2.01 ft	1	1	0.213	0.013	-0.00	-66.88	66.88	525.00	314.37	1.02	1.00	2.08	234.00	156.00
Dsgn. L = 2.01 ft	1	1	0.203	0.020	-0.00	-63.76	63.76	525.00	314.37	1.03	1.00	3.15	234.00	156.00
Dsgn. L = 2.01 ft	1	1	0.186	0.027	-0.00	-58.49	58.49	525.00	314.37	1.05	1.00	4.22	234.00	156.00
Dsgn. L = 2.01 ft	1	1	0.162	0.034	-0.00	-51.08	51.08	525.00	314.37	1.07	1.00	5.28	234.00	156.00
Dsgn. L = 2.01 ft	1	1	0.132	0.041	-0.00	-41.53	41.53	525.00	314.37	1.12	1.00	6.35	234.00	156.00
Dsgn. L = 2.01 ft	1	1	0.095	0.048	-0.00	-29.83	29.83	525.00	314.37	1.21	1.00	7.42	234.00	156.00
Dsgn. L = 2.01 ft	1	1	0.051	0.054		-15.99	15.99	525.00	314.37	1.00	1.00	8.48	234.00	156.00
+0.60D														
Dsgn. L = 1.92 ft	1	1	0.013	0.014	4.03		4.03	525.00	314.37	1.69	1.00	2.23	234.00	156.00
Dsgn. L = 2.01 ft	1	1	0.024	0.013	7.70	4.03	7.70	525.00	314.37	1.23	1.00	1.96	234.00	156.00
Dsgn. L = 2.01 ft	1	1	0.034	0.011	10.80	7.70	10.80	525.00	314.37	1.13	1.00	1.68	234.00	156.00
Dsgn. L = 2.01 ft	1	1	0.042	0.009	13.34	10.80	13.34	525.00	314.37	1.08	1.00	1.40	234.00	156.00
Dsgn. L = 2.01 ft	1	1	0.049	0.007	15.32	13.34	15.32	525.00	314.37	1.05	1.00	1.12	234.00	156.00
Dsgn. L = 2.01 ft	1	1	0.053	0.005	16.73	15.32	16.73	525.00	314.37	1.03	1.00	0.84	234.00	156.00
Dsgn. L = 2.01 ft	1	1	0.056	0.004	17.57	16.73	17.57	525.00	314.37	1.02	1.00	0.56	234.00	156.00
Dsgn. L = 2.01 ft	1	1	0.057	0.002	17.86	17.57	17.86	525.00	314.37	1.00	1.00	0.28	234.00	156.00
Dsgn. L = 1.92 ft	1	1	0.057	0.002	17.86	17.60	17.86	525.00	314.37	1.00	1.00	0.27	234.00	156.00
Dsgn. L = 2.01 ft	1	1	0.056	0.004	17.60	16.78	17.60	525.00	314.37	1.02	1.00	0.55	234.00	156.00

Steel Beam Project File: 23-11-01_Gruening Boiler Rm Beam_eh.ec6

LIC#: KW-06017697, Build:20.23.10.31 REID MIDDLETON, INC. (c) ENERCALC INC 1983-2023

DESCRIPTION: New Boiler Room Beam WIND

Maximum Forces & Stresses for Load Combinations

Load Combination	Segment Length	Span #	Max Stress Ratios		Summary of Moment Values						Summary of Shear Values			
			M	V	Mmax +	Mmax -	Ma Max	Mnx	Mnx/Omega	Cb	Rm	Va Max	VnxVnx/Omega	
Dsgn. L = 2.01 ft	2.01 ft	1	0.053	0.005	16.78	15.39	16.78	525.00	314.37	1.03	1.00	0.83	234.00	156.00
Dsgn. L = 2.01 ft	2.01 ft	1	0.049	0.007	15.39	13.44	15.39	525.00	314.37	1.05	1.00	1.11	234.00	156.00
Dsgn. L = 2.01 ft	2.01 ft	1	0.043	0.009	13.44	10.93	13.44	525.00	314.37	1.07	1.00	1.39	234.00	156.00
Dsgn. L = 2.01 ft	2.01 ft	1	0.035	0.011	10.93	7.85	10.93	525.00	314.37	1.12	1.00	1.67	234.00	156.00
Dsgn. L = 2.01 ft	2.01 ft	1	0.025	0.013	7.85	4.21	7.85	525.00	314.37	1.21	1.00	1.95	234.00	156.00
Dsgn. L = 2.01 ft	2.01 ft	1	0.013	0.014	4.21		4.21	525.00	314.37	1.61	1.00	2.23	234.00	156.00

Overall Maximum Deflections

Load Combination	Span	Max. "-" Defl	Location in Span	Load Combination	Max. "+" Defl	Location in Span
	1	0.0000	0.000	W Only	-0.8001	16.091

Vertical Reactions

Load Combination	Support notation : Far left is #'		Values in KIPS	
	Support 1	Support 2		
Max Upward from all Load Conditions	3.720	3.720		
Max Upward from Load Combinations	2.232	2.232		
Max Upward from Load Cases	3.720	3.720		
Max Downward from all Load Conditions (Resis	-17.856	-17.856		
Max Downward from Load Combinations (Resi	-8.482	-8.482		
Max Downward from Load Cases (Resisting Up	-17.856	-17.856		
D Only	3.720	3.720		
+D+0.60W	-6.994	-6.994		
+D+0.450W	-4.315	-4.315		
+0.60D+0.60W	-8.482	-8.482		
+0.60D	2.232	2.232		
W Only	-17.856	-17.856		



4300 B Street, Suite 302
 Anchorage, Alaska 99502
 Ph: 907 562-3439
 Fax: 907 561-5319

Client ASD
 Project Gruening Middle School
 Boiler Room Bm Replacement
 Project No. 402023.136
 Sheet _____ of _____
 Design by EH
 Date 11/2/2023
 Checked by _____
 Date _____

~ SHEAR TAB CONNECTION PER AISC 13TH EDITION ~

INPUT:						
Beam size:	W21x55	Method:	ASD			
Beam Yield Stress:	$F_{yBM} = 50$ ksi	Dead Load:	$R_D = 4.5$ k			
Beam Ultimate Stress:	$F_{uBM} = 65$ ksi	Live Load:	$R_L = 0$ k			
Plate Yield Stress:	$F_{yPL} = 36$ ksi	Snow Load:	$R_S = 16.12$ k			
Plate Ultimate Stress:	$F_{uPL} = 50$ ksi	Total Load:	$R_T = 20.62$ k			
Plate Thickness:	$t_{wPL} = 0.375$ in	Connection: OK				
A325 Bolt Shear Stress:	$F_{vbolt} = 54$ ksi	CONNECTION PROPERTIES				
Number of Bolts:	$n = 5.0$	Beam depth:	$d = 20.8$ in			
Bolt Diameter:	dia. = 0.75 in	Beam web depth:	$d-2t_f = 19.756$ in			
Bm-Col Gap:	gap = 0.5 in	Web thickness:	$t_w = 0.375$ in			
Edge Distance 1:	$ed_1 = 1.5$ in	Plate depth:	$d_{PL} = 16$ in			
Edge Distance 2:	$ed_2 = 1.5$ in	Plate Gross Area:	$A_{gPL} = 6$ in ²			
Edge Distance 3:	$ed_3 = 2$ in	Plate Net Area:	$A_{ePL} = 4.24$ in ²			
Bolt Group Coefficient:	$C_b = 4.39$ Table 7-7	Bolt Area:	$A_{bolt} = 0.44$ in ²			
Weld Group Coefficient:	$C_w = 3.72$ Table 8-4	Bolt Spacing:	$s = 3$ in			
# of 1/16" in fillet weld size:	$D = 5$	Eccentricity:	$e_x = 2$ in			
		For Table 8-4:	$a = 0.13$			
OUTPUT:		V_n or R_n	Ω	Φ	R_n/Ω	AISC Ref.
Plate Shear Yielding:	$V_n = 0.6F_yA_g =$	129.6 k	1.50	1.00	86.4 k	J4-3
Plate Shear Rupture:	$V_n = 0.6F_uA_{nv} =$	127.3 k	2.00	0.75	63.6 k	J4-4
Plate Tensile Yielding:	$R_n = F_yA_g =$	216.0 k	1.67	0.90	129.3 k	J4-1
Plate Tensile Rupture:	$R_n = F_uA_e =$	212.1 k	2.00	0.75	106.1 k	J4-2
Bolts in Shear:	$R_n = (F_nA_b) * C_b =$	23.9 k/bolt	2.00	0.75	52.4 k	J3-1
Plate Bearing Strength:	$R_n = 1.2L_c t F_u < 2.4dt F_u =$	168.8 k	2.00	0.75	84.4 k	J3-6a
	$L_{c,edge} = 1.5938$ in 35.9 k > 33.8 k					
	$L_{c,int} = 2.1875$ in 49.2 k > 33.8 k					
Beam Bearing Strength:	$R_n = 1.2L_c t F_u < 2.4dt F_u =$	219.4 k	2.00	0.75	109.7 k	J3-6a
	$L_{c,edge} = 3.878$ in 113.4 k > 43.9 k					
	$L_{c,int} = 2.1875$ in 64.0 k > 43.9 k					
Plate Block Shear:	$R_n = 0.6F_uA_{nv} + U_{bs}F_uA_{nt} \leq$ $0.6F_yA_{gv} + U_{bs}F_uA_{nt} =$	129.4 k	2.00	0.75	64.7 k	J3-6a
	$A_{gv} = 5.25$ in ² 129.4 k < 132.7 k					
	$A_{nv} = 3.67$ in ²					
	$A_{nt} = 0.39$ in ²					
Beam Block Shear:	$R_n = 0.6F_uA_{nv} + U_{bs}F_uA_{nt} \leq$ $0.6F_yA_{gv} + U_{bs}F_uA_{nt} =$	195.7 k	2.00	0.75	97.8 k	J3-6a
	$A_{gv} = 7.41$ in ² 195.7 k < 247.4 k					
	$A_{nv} = 4.37$ in ²					
	$A_{nt} = 0.39$ in ²					
Fillet Weld:	$R_n = C_w DL =$	297.6 k	2.00	0.75	148.8 k	J2-4
CONNECTION SUMMARY:						
No. bolts:	5 bolts	DCR: 0.39				
Bolt dia:	3/4 in					
PL thickness:	3/8 in					
PL width:	3 1/2 in					
PL Length:	16.0 in					
Fillet Weld Size:	5/16 in					
Bolt Spacing:	3.0 in					

GENERAL STRUCTURAL NOTES

GENERAL
THE CONTRACTOR MUST VERIFY AND COORDINATE ALL DIMENSIONS AMONG THE DRAWINGS BEFORE STARTING ANY WORK OR FABRICATION. IN CASE OF DISCREPANCIES BETWEEN DRAWINGS, REFERENCE STANDARDS, SITE CONDITIONS OR GOVERNING CODE, THE MORE STRINGENT REQUIREMENTS MUST GOVERN. CONTRACTOR MUST NOTIFY THE ENGINEER OF DISCREPANCIES AND OBTAIN DIRECTION PRIOR TO PROCEEDING. NOTES ON INDIVIDUAL STRUCTURAL DRAWINGS MUST TAKE PRIORITY OVER GENERAL STRUCTURAL NOTES. NOTED DIMENSIONS TAKE PRECEDENCE OVER SCALED DIMENSIONS. DO NOT SCALE DRAWINGS. TYPICAL DETAILS MAY NOT NECESSARILY BE INDICATED AS TYP ON THE PLANS BUT MUST APPLY AS SHOWN OR DESCRIBED IN THE DETAILS.

ALL CONSTRUCTION MUST COMPLY WITH THE 2018 INTERNATIONAL BUILDING CODE (IBC) AS AMENDED AND ADOPTED BY THE MUNICIPALITY OF ANCHORAGE (MOA).

SAFETY - THE CONTRACTOR IS RESPONSIBLE FOR MEETING ALL FEDERAL, STATE AND LOCAL SAFETY STANDARDS. THE CONTRACTOR IS IN CHARGE OF ALL SAFETY MATTERS ON AND AROUND THE JOB SITE.

STRUCTURAL DESIGN DATA
STRUCTURAL DESIGN IS IN ACCORDANCE WITH THE IBC AS AMENDED AND ADOPTED BY THE MUNICIPALITY OF ANCHORAGE. RISK CATEGORY IS III IN ACCORDANCE WITH IBC SECTION 1604.5. STRUCTURAL DESIGN IS IN ACCORDANCE WITH THE 2018 IBC AND 2018 IEBC AS AMENDED AND ADOPTED BY THE MUNICIPALITY OF ANCHORAGE. WORK UNDER THE IEBC IS CONSIDERED A REPAIR.

THE STRUCTURE HAS BEEN DESIGNED FOR THE FOLLOWING OPERATIONAL LOADS ON THE COMPLETED STRUCTURES. CONTRACTOR IS RESPONSIBLE FOR TEMPORARY SHORING AND BRACING DURING CONSTRUCTION.

SNOW LOADS: GROUND SNOW (Pg) = 50 PSF
Is=1.1, Ct=1.0, Ce=1.0
ROOF SNOW = 40 PSF SLOPED + UNBALANCED SNOW

WIND LOADS: BASIC WIND SPEED (3-SECOND GUST, Vult)=130 MPH,
C&C WIND LOAD = 72 PSF

EXISTING CONDITIONS
CONTRACTOR MUST VERIFY ALL EXISTING DIMENSIONS, MEMBER SIZES, AND CONDITIONS PRIOR TO COMMENCING WORK. DIMENSIONS OF EXISTING CONSTRUCTION SHOWN ON THE DRAWINGS ARE INTENDED AS GUIDELINES ONLY AND MUST BE VERIFIED. EXISTING CONDITIONS SHOWN ON DRAWINGS ARE BASED ON EITHER SITE OBSERVATIONS, ORIGINAL DRAWINGS, OR WERE ASSUMED BASED ON EXPECTED CONDITIONS. IF EXISTING CONDITIONS DO NOT CLOSELY MATCH CONDITIONS SHOWN ON DRAWINGS, OR IF EXISTING MATERIALS ARE OF QUESTIONABLE OR SUBSTANDARD QUALITY, NOTIFY ENGINEER PRIOR TO COMMENCING WORK.

SPECIAL INSPECTION
SPECIAL INSPECTION IS NOT REQUIRED.

SUBMITTALS
THE CONTRACTOR MUST REVIEW, STAMP WITH THEIR APPROVAL, DATE AND SIGN ALL SHOP DRAWINGS AND SUBMITTALS REQUIRED BY THE CONTRACT DRAWINGS PRIOR TO SUBMITTAL TO THE ENGINEER. AT THE TIME OF SUBMISSION, THE CONTRACTOR MUST INFORM THE ENGINEER IN WRITING OF ANY DEVIATION IN THE SHOP DRAWINGS FROM THE REQUIREMENTS OF THE CONTRACT DRAWINGS. DIMENSIONS AND QUANTITIES ARE THE CONTRACTOR'S RESPONSIBILITY AND WILL NOT BE REVIEWED.

STRUCTURAL STEEL
MATERIALS:
WIDE-FLANGE SHAPES: ASTM A992
ALL OTHER SHAPES & PLATE: ASTM A36
BOLTS, WASHERS & NUTS: ASTM F3125, F436 & A563
HARDENED WASHERS: ASTM F436
BOLTS THROUGH CMU & WOOD: ASTM A307

ALL DETAILING, FABRICATION AND ERECTIONS MUST CONFORM TO AISC SPECIFICATIONS AND CODES, LATEST EDITION. FABRICATOR MUST PARTICIPATE IN THE AISC QUALITY CERTIFICATION PROGRAM, BE CERTIFIED BY THE MUNICIPALITY OF ANCHORAGE, OR SPECIAL INSPECTIONS AT THE CONTRACTOR'S EXPENSE, MUST BE PROVIDED IN THE FABRICATION SHOP.

ALL WELDING MUST BE DONE BY QUALIFIED WELDERS AND MUST CONFORM TO THE AWS D1.1 AND D1.8, LATEST EDITIONS. ALL WELDING ELECTRODES MUST BE PROPERLY CONDITIONED TO 70 KSI MINIMUM TENSILE STRENGTH, WITH DIFFUSED HYDROGEN LEVELS OF 16ml/g (H16) OR LESS IN ACCORDANCE WITH AWS A4.3.

THERE MUST BE NO FIELD CUTTING OF STRUCTURAL STEEL MEMBERS FOR THE WORK OF OTHER TRADES WITHOUT THE PRIOR APPROVAL OF THE ENGINEER.

ALL CONNECTIONS MUST BE SIMPLE, SINGLE PLATE SHEAR CONNECTIONS USING HIGH-STRENGTH BEARING TYPE BOLTS WITH THREADS INCLUDED IN THE SHEAR PLANE, A325-N, UON. NUTS MUST BE SNUG-TIGHT, UON. ONE PLY OF THE CONNECTION MUST USE SHORT-SLOTTED HOLES ORIENTED HORIZONTALLY.

THE CONTRACTOR MUST BE RESPONSIBLE FOR THE CONTROL OF ALL ERECTION PROCEDURES AND SEQUENCES. CONSIDERATION SHOULD BE GIVEN TO TEMPERATURE DIFFERENTIALS, ESPECIALLY WITH RESPECT TO STRUCTURAL STEEL FRAMING INTO CONCRETE WALLS, BEAMS, OR COLUMNS.

ALL STEEL MUST BE CLEANED BY METHODS COMPLYING WITH THE STEEL STRUCTURES PAINTING COUNCIL METHOD SSPC-SP3, POWER TOOL CLEANING. REMOVE OIL, GREASE, AND SIMILAR CONTAMINANTS. EXCEPT FOR MEMBERS TO BE WELDED, APPLY STRUCTURAL STEEL PRIMER PAINT IN ACCORDANCE WITH THE MANUFACTURER'S INSTRUCTIONS TO A UNIFORM DRY FILM THICKNESS OF 2.0 MILS. AFTER FINAL STEEL INSTALLATION, WIRE BRUSH EXPOSED STEEL SURFACES AND CLEAN WITH SOLVENTS BEFORE TOUCH-UP PAINTING.

THE CONTRACTOR MUST SUBMIT SHOP DRAWINGS TO THE ENGINEER FOR REVIEW. THESE DRAWINGS MUST BE CHECKED BY THE CONTRACTOR BEFORE SUBMITTAL AND MUST SHOW SHOP FABRICATION DETAILS, FIELD ASSEMBLY DETAILS, AND ERECTION DIAGRAMS FOR ALL STRUCTURAL STEEL.

STRUCTURAL MASONRY
GROUT MUST MEET ASTM C476. PROPORTIONS MUST COMPLY WITH TMS 602-16 TABLE SC-7. MINIMUM COMPRESSIVE STRENGTH = 2,000 PSI. PROVIDE ADEQUATE TEMPORARY BRACING DURING CONSTRUCTION TO WITHSTAND LATERAL LOADS AND THE PRESSURES OF FLUID GROUT.



100%
SUBMITTAL



GRUENING MIDDLE SCHOOL - BOILER ROOM BEAM REPLACEMENT & UPGRADES
ANCHORAGE SCHOOL DISTRICT

REVISION SCHEDULE		
#	DESCRIPTION	DATE

DATE: 11/27/23
PROJECT #: 402023.136
DRAWN BY: EH
CHECKED BY: DS

SHEET DESCRIPTION:
STRUCTURAL
NOTES & DETAILS

SHEET NO:
S0.1

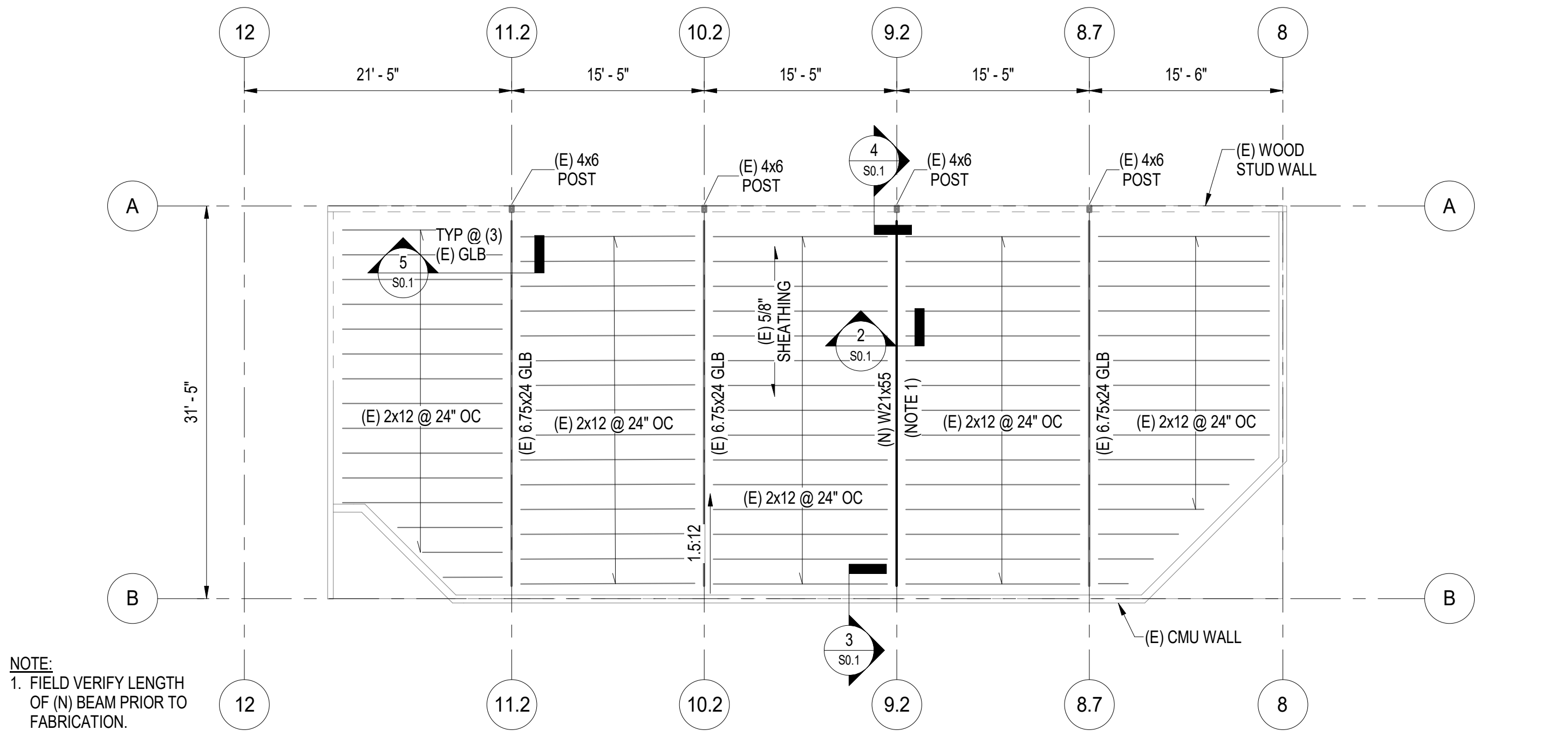

NOTE:
1. FIELD VERIFY LENGTH OF (N) BEAM PRIOR TO FABRICATION.

1 ROOF PLAN - BOILER ROOM
S0.1 1/8" = 1'-0"

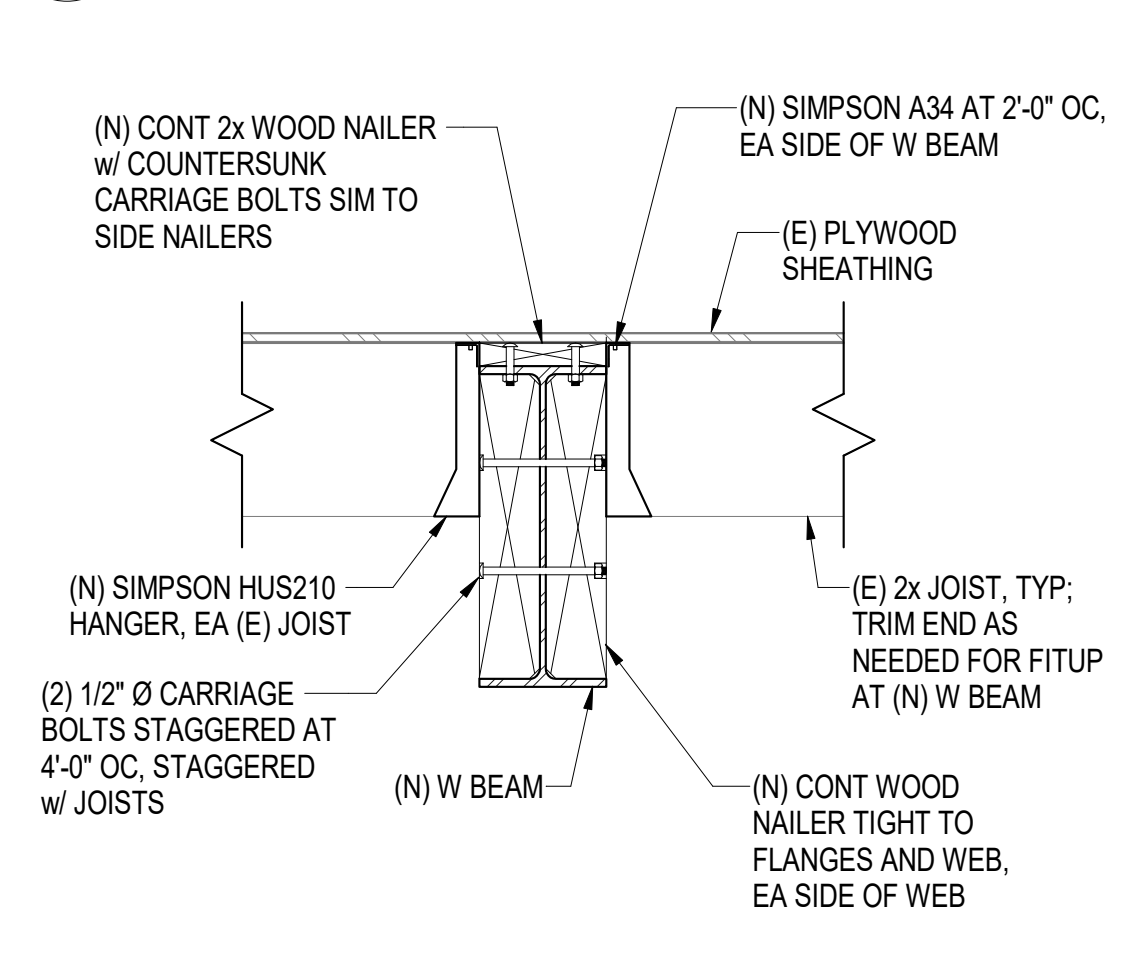

2 SECTION AT (N) W BEAM
S0.1 1" = 1'-0"

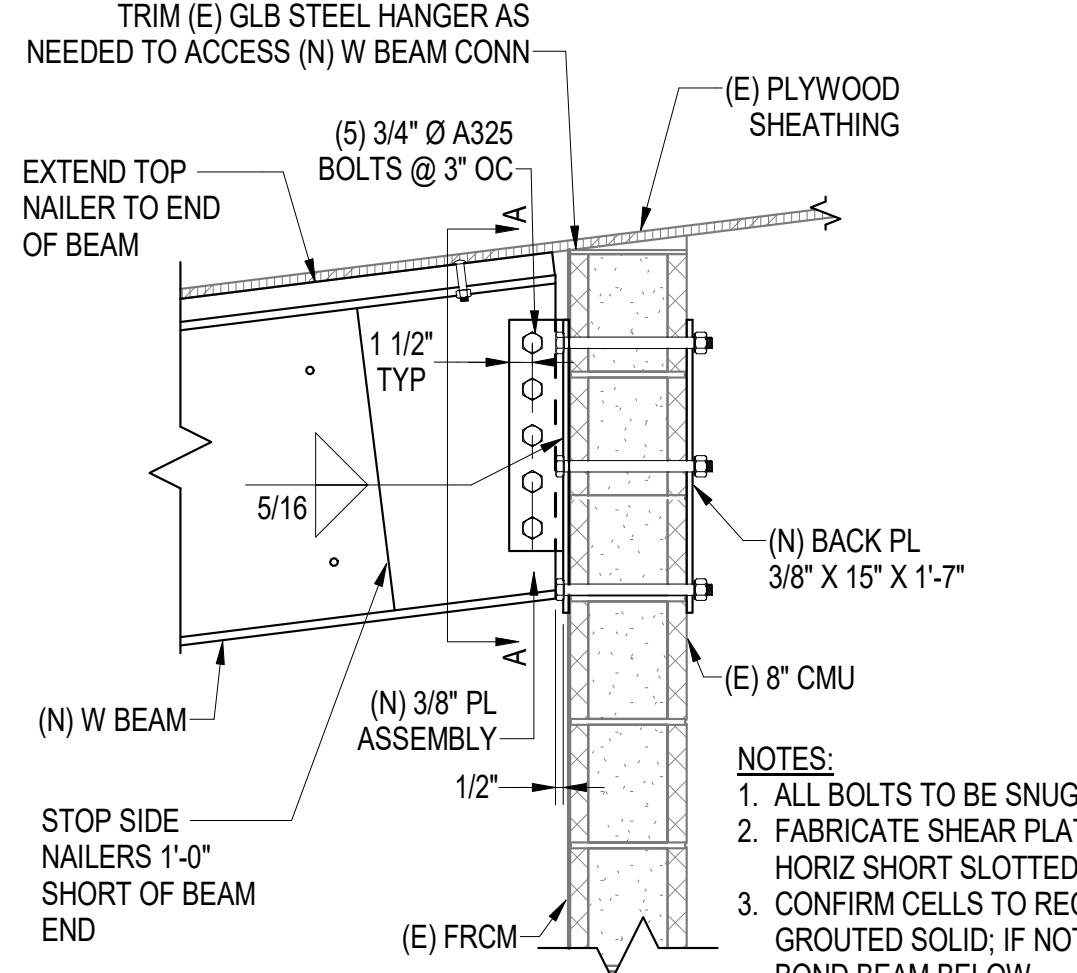

3 (N) W BEAM TO (E) CMU WALL
S0.1 1" = 1'-0"

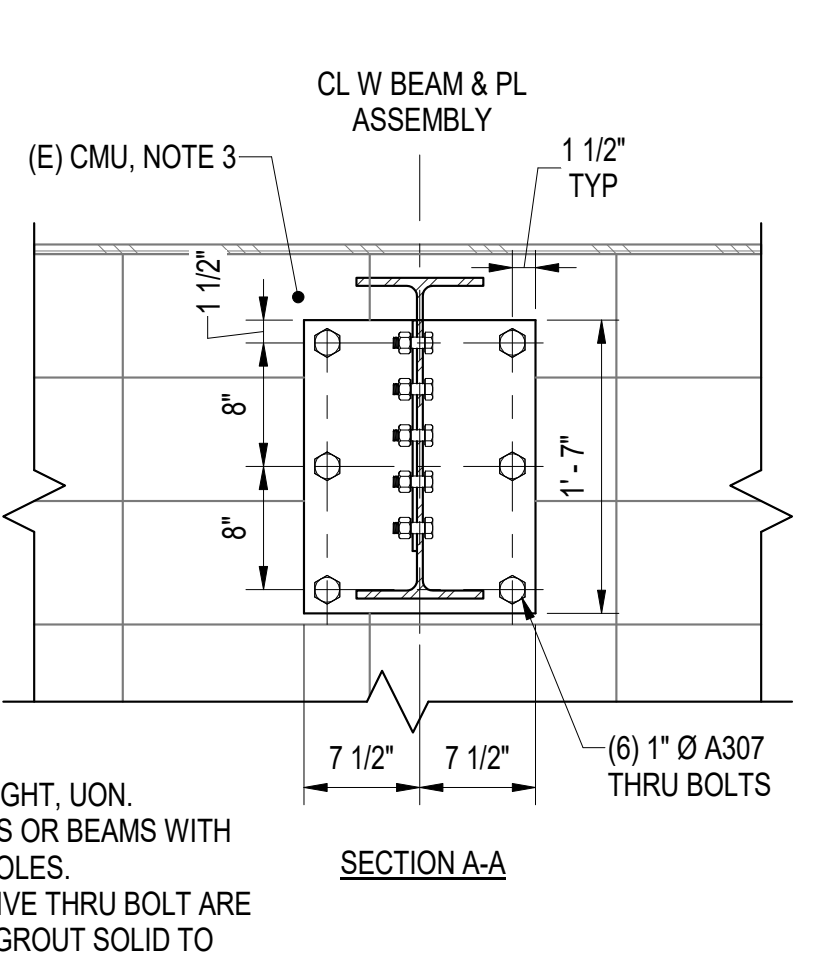

5 SECTION AT (E) GLB
S0.1 1" = 1'-0"

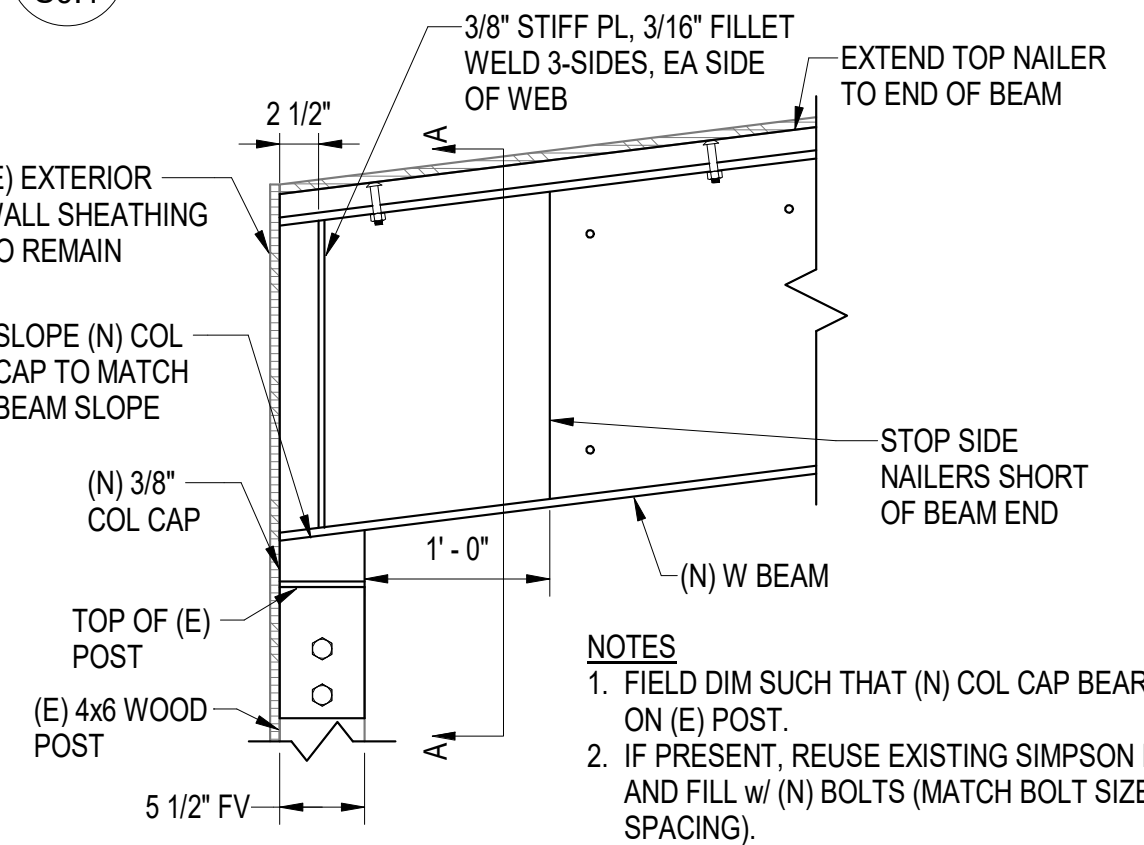

4 (N) W BEAM TO (E) WOOD POST
S0.1 1" = 1'-0"

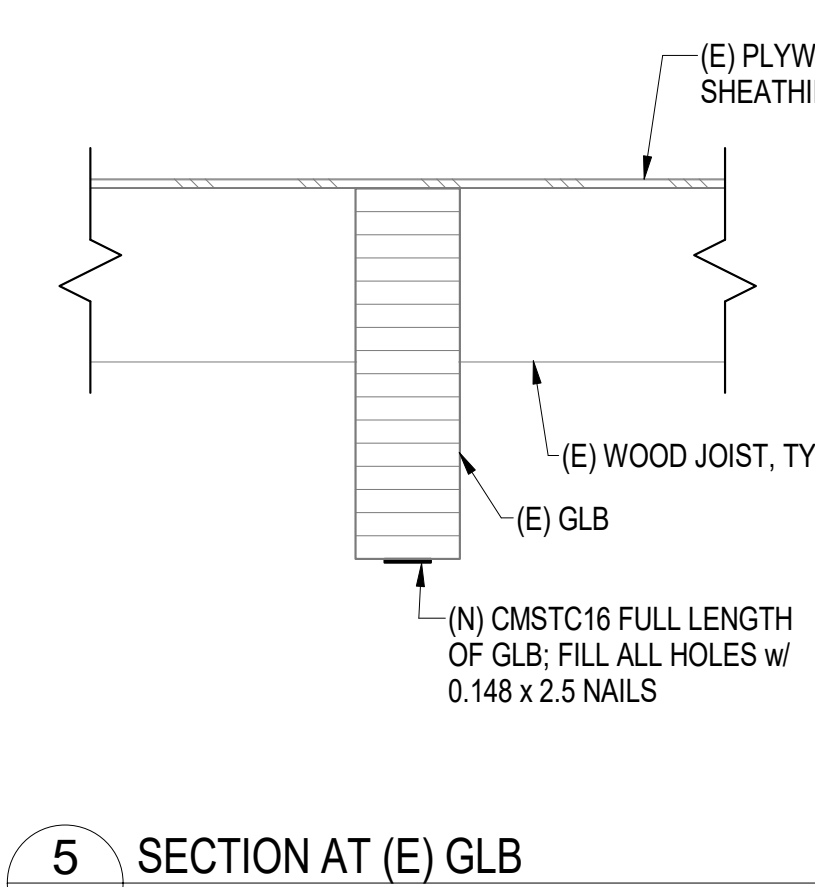
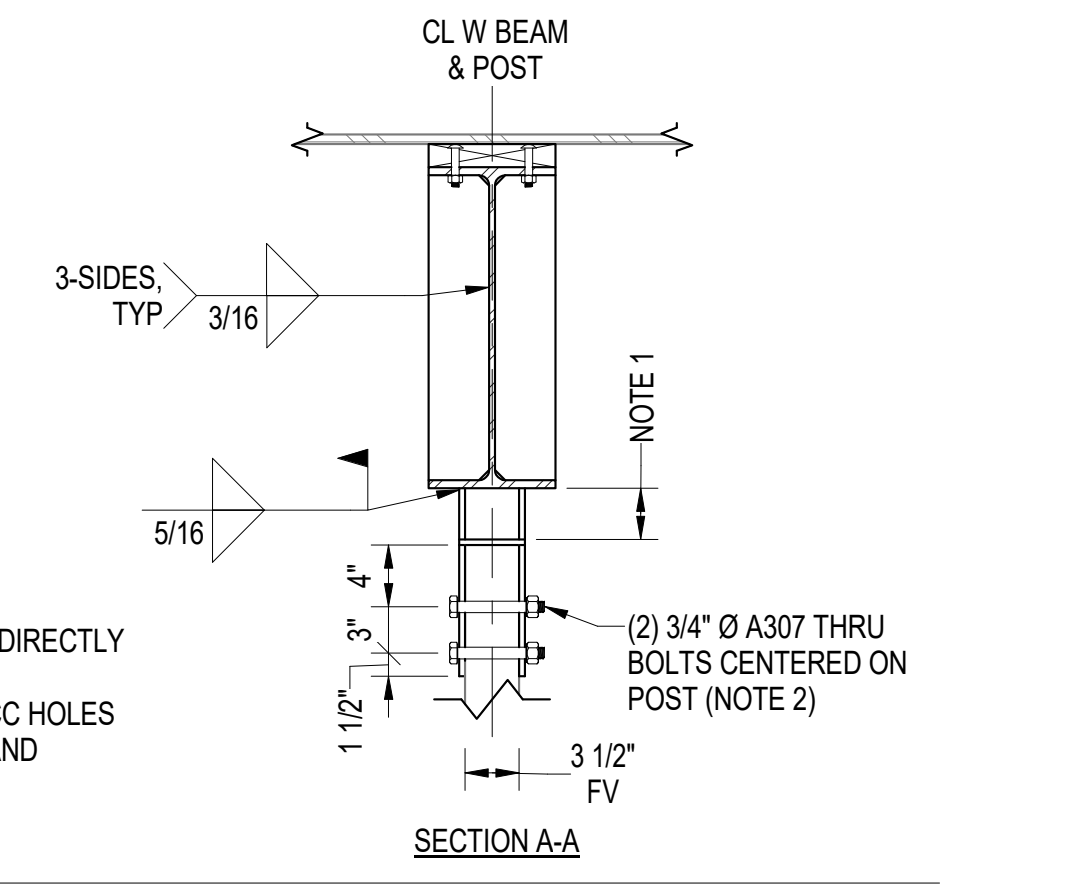

ABBREVIATIONS	
COL	COLUMN
CONT	CONTINUOUS
CL	CENTERLINE
DIM	DIMENSION
(E)	EXISTING
EA	EACH
FRCM	FABRIC-REINFORCED CEMENTITIOUS MATRIX
FV	FIELD VERIFY
GLB	GLUE LAMINATED BEAM
HORIZ	HORIZONTAL
(N)	NEW
OC	ON CENTER
PL	PLATE
SIM	SIMILAR
STIFF	STIFFENER
TYP	TYPICAL
UON	UNLESS OTHERWISE NOTED
w/	WITH
W	WIDE FLANGE
@	AT
&	AND
Ø	DIAMETER

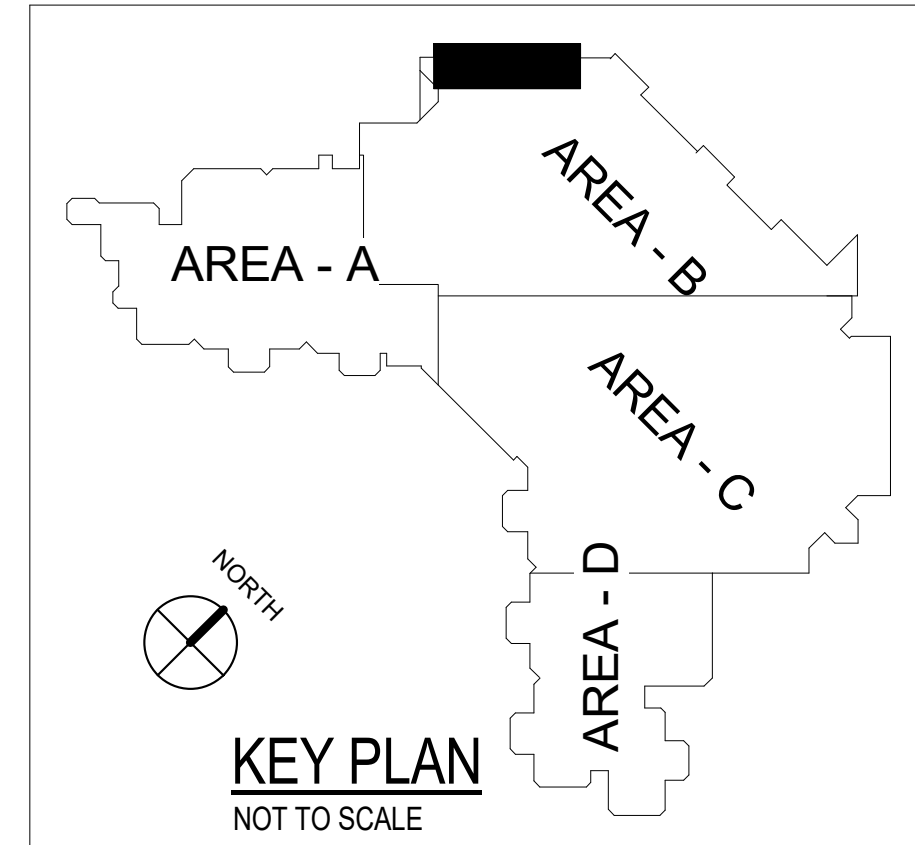



Capital Planning & Construction

Job #: 730017 Gruening MS Boiler Replacement

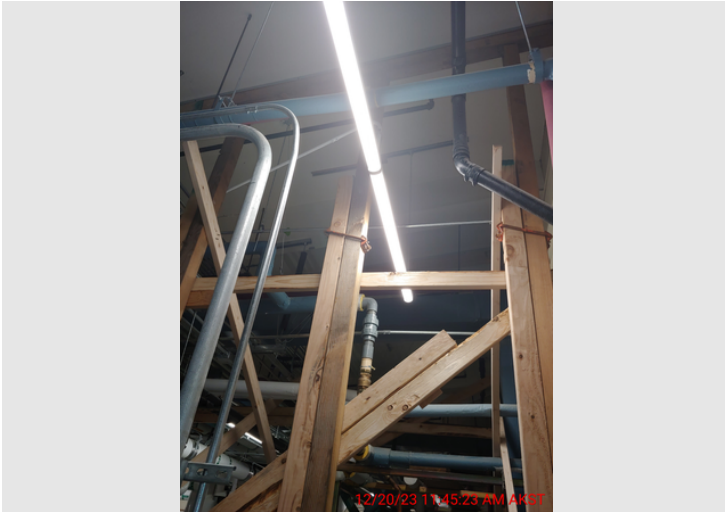

Description

Taken Date

12/20/2023 at 11:45 am

Uploaded By

David Shafer

Upload Date

12/20/2023 at 11:48 am

File Name

IMG_2023_12_20_11_45_20_753.j...



Description

Taken Date

12/20/2023 at 11:45 am

Uploaded By

David Shafer

Upload Date

12/20/2023 at 11:47 am

File Name

IMG_2023_12_20_11_45_07_585.j...

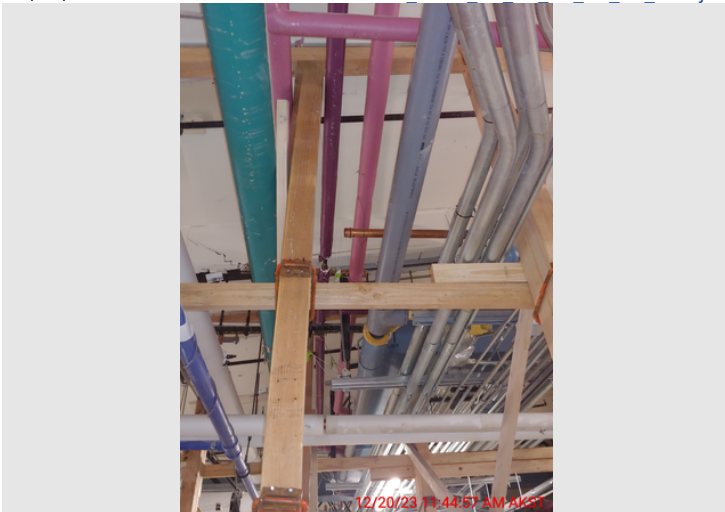

Description

Taken Date

12/20/2023 at 11:44 am

Uploaded By

David Shafer

Upload Date

12/20/2023 at 11:46 am

File Name

IMG_2023_12_20_11_44_54_087.j...

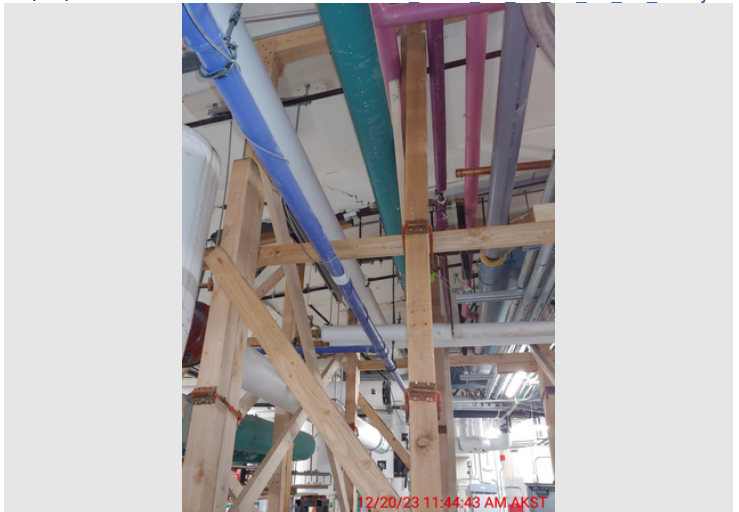

Description

Taken Date

12/20/2023 at 11:44 am

Uploaded By

David Shafer

Upload Date

12/20/2023 at 11:46 am

File Name

IMG_2023_12_20_11_44_40_903.j...



Capital Planning & Construction



Description

Taken Date

12/20/2023 at 11:42 am

Uploaded By

David Shafer

Upload Date

12/20/2023 at 11:43 am

File Name

[IMG_2023_12_20_11_42_33_484.j...](#)



Description

Taken Date

Upload Date

12/04/2023 at 10:30 am

Uploaded By

Yuki Janson

File Name

[11-10-2023 image009 \(1\).jpg](#)

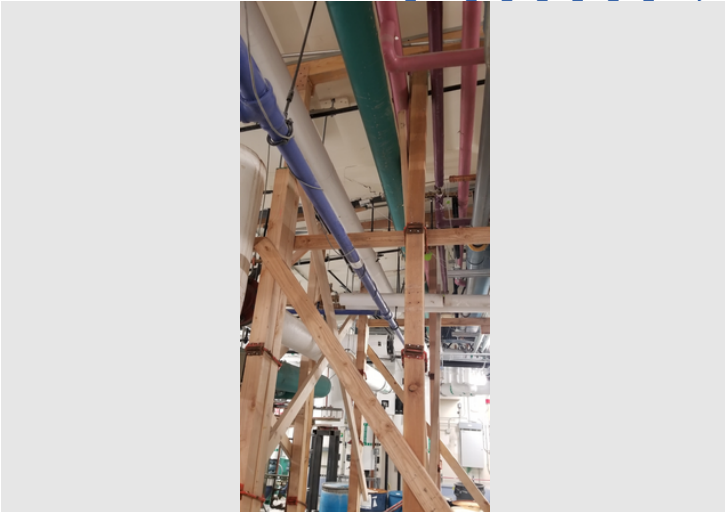

Description

Taken Date

Upload Date

12/04/2023 at 10:30 am

Uploaded By

Yuki Janson

File Name

[11-10-2023 image009 \(7\).jpg](#)

A. GENERAL

Proposers/Offerors are advised that, notwithstanding any instructions or implications elsewhere in this RFP, only the documents shown and detailed on this Check List need to be submitted with and made part of their proposal/offer. Proposers/Offerors are hereby advised that failure to submit the documents shown and detailed on this Check List may be justification for rendering the proposal/offer non-responsive.

B. REQUIRED DOCUMENTS FOR OFFER PROPOSAL SUBMISSION

1. Attachment A, Proposal Transmittal Form
2. All addenda issued should be acknowledged by manually signing the Addenda sheet and submitting it prior to the offer opening, or by indicating acknowledgement in the space provided on the Attachment A, Proposal Transmittal Form.

Items 3, 4 & 5 TO BE SUBMITTED AS PART OF BID/PROPOSAL OR WITHIN THREE (3) CALENDAR DAYS OF NOTICE FROM THE DISTRICT (ASD). DBE PARTICIPATION REQUIREMENTS MUST BE COMPLETED/FINISHED BY THE PROPOSAL SUBMISSION DATE.

3. Exhibit 1, Supplemental Term, Conditions and Forms
 - ✓ 1. Acknowledgement of Terms, Conditions, and Grant Clauses General Grant Clauses
 - ✓ 2. Certification Regarding Lobbying
4. Exhibit 3, Disadvantaged Business Enterprises, Prime Consultant/Contractor Certification
 - ✓ 1. Prime Consultant/Contractor Certification
5. Exhibit 4, Disadvantaged Business Enterprises, Contact Documentation Form
 - ✓ 1. Contact Documentation Form

EXHIBIT 1: SUPPLEMENTAL TERMS AND CONDITIONS

(2 C.F.R. § 200.326 and 2 C.F.R. Part 200, Appendix II, Required Contract Clauses)

The supplemental conditions contained in this section are intended to cooperate with, to supplement, and to modify the general conditions and other specifications **for the acquisition of supplies, services, equipment, or construction services to insure compliance with 2 C.F.R. § 200.317 through 200.327 and 2 C.F.R. Part 200, Appendix II** for contracts being awarded using Federal Grant funds.

1. Flow Down of Terms and Conditions from the Grant Agreement

Subcontracts: If the vendor Subcontracts any of the work required under this Agreement, a copy of the signed Subcontract must be forwarded to the Anchorage School District (“District”) for review and approval. The vendor agrees to include in the Subcontract that (i) the Subcontractor is bound by the terms of this Agreement, (ii) the Subcontractor is bound by all applicable local, state and federal laws and regulations, and (iii) the Subcontractor shall hold the District harmless against all claims of whatever nature arising out of the Subcontractor’s performance of work under this Agreement, to the extent allowed and required by law.

2. Compliance with Executive Order 11246 of September 24, 1965, entitled “Equal Employment Opportunity,” as amended by Executive Order 11375 of October 13, 1967, and as supplemented in Department of Labor regulations

During the performance of this contract, the Contractor agrees as follows:

- (1) The Contractor will not discriminate against any employee or applicant for employment because of race, creed, color, or national origin. The Contractor will take affirmative action to ensure that applicants are employed, and that employees are treated during employment, without regard to their race, creed, color, or national origin. Such action shall include, but not be limited to the following: employment, upgrading, demotion, or transfer; recruitment or recruitment advertising; layoff or termination; rates of pay or other forms of compensation; and selection for training, including apprenticeship. The Contractor agrees to post in conspicuous places, available to employees and applicants for employment, notices to be provided by the contracting officer setting forth the provisions of this nondiscrimination clause.
- (2) The Contractor will, in all solicitations or advertisements for employees placed by or on behalf of the Contractor, state that all qualified applicants will receive consideration for employment without regard to race, creed, color, or national origin.
- (3) The Contractor will send to each labor union or representative of workers with which he has a collective bargaining agreement or other contract or understanding, a notice, to be provided by the agency contracting officer, advising the labor union or workers’ representative of the Contractor’s commitments under Section 202 of Executive Order No. 11246 of September 24, 1965, as amended by Executive Order No. 11375, and shall post copies of the notice in conspicuous places available to employees and applicants for employment.
- (4) The Contractor will comply with all provisions of Executive Order No. 11246 of Sept. 24, 1965, and of the rules, regulations, and relevant orders of the Secretary of Labor.
- (5) The Contractor will furnish all information and reports required by Executive Order No. 11246 of September 24, 1965, and by the rules, regulations, and orders of the Secretary of Labor, or pursuant thereto, and will permit access to his books, records, and accounts by the contracting agency and the Secretary of Labor for purposes of investigation to ascertain compliance with such rules, regulations, and orders.

Exhibit 1
Supplemental Terms, Conditions and Forms

- (6) In the event of the Contractor's noncompliance with the nondiscrimination clauses of this contract or with any of such rules, regulations, or orders, this contract may be cancelled, terminated or suspended in whole or in part and the Contractor may be declared ineligible for further Government contracts in accordance with procedures authorized in Executive Order No. 11246 of Sept 24, 1965, and such other sanctions may be imposed and remedies invoked as provided in Executive Order No. 11246 of September 24, 1965, or by rule, regulation, or order of the Secretary of Labor, or as otherwise provided by law.
- (7) The Contractor will include the *portion of the sentence immediately preceding the first paragraph* and the provisions of Paragraphs (1) through (7) in every Subcontract or purchase order unless exempted by rules, regulations, or orders of the Secretary of Labor issued pursuant to Section 204 of Executive Order No. 11246 of Sept. 24, 1965, so that such provisions will be binding upon each Subcontractor or Vendor. The Contractor will take such action with respect to any Subcontract or Purchase Order as the contracting agency may direct as a means of enforcing such provisions including sanctions for noncompliance: Provided, however, That in the event the Contractor becomes involved in, or is threatened with, litigation with a Subcontractor or Vendor as a result of such direction by the contracting agency, the Contractor may request the United States to enter into such litigation to protect the interests of the United States."
- (8) The contractor will include the portion of the sentence immediately preceding paragraph (1) and the provisions of paragraphs (1) through (8) in every subcontract or purchase order unless exempted by rules, regulations, or orders of the Secretary of Labor issued pursuant to section 204 of Executive Order 11246 of September 24, 1965, so that such provisions will be binding upon each subcontractor or vendor. The contractor will take such action with respect to any subcontract or purchase order as the administering agency may direct as a means of enforcing such provisions, including sanctions for noncompliance: Provided, however, that in the event a contractor becomes involved in, or is threatened with, litigation with a subcontractor or vendor as a result of such direction by the administering agency, the contractor may request the United States to enter into such litigation to protect the interests of the United States. The applicant further agrees that it will be bound by the above equal opportunity clause with respect to its own employment practices when it participates in federally assisted construction work: Provided that if the applicant so participating is a State or local government, the above equal opportunity clause is not applicable to any agency, instrumentality or subdivision of such government which does not participate in work on or under the contract. The applicant agrees that it will assist and cooperate actively with the administering agency and the Secretary of Labor in obtaining the compliance of contractors and subcontractors with the equal opportunity clause and the rules, regulations, and relevant orders of the Secretary of Labor, that it will furnish the administering agency and the Secretary of Labor such information as they may require for the supervision of such compliance, and that it will otherwise assist the administering agency in the discharge of the agency's primary responsibility for securing compliance. The applicant further agrees that it will refrain from entering into any contract or contract modification subject to Executive Order 11246 of September 24, 1965, with a contractor debarred from, or who has not demonstrated eligibility for, Government contracts and federally assisted construction contracts pursuant to the Executive Order and will carry out such sanctions and penalties for violation of the equal opportunity clause as may be imposed upon contractors and subcontractors by the administering agency or the Secretary of Labor pursuant to Part II, Subpart D of the Executive Order. In addition, the applicant agrees that if it fails or refuses to comply with these undertakings, the administering agency may take any or all of the following actions: Cancel, terminate, or suspend in whole or in part this grant (contract, loan, insurance, guarantee); refrain from extending any further assistance to the applicant under the program with respect to which the failure or refund occurred until satisfactory assurance of

future compliance has been received from such applicant; and refer the case to the Department of Justice for appropriate legal proceedings.

3. Davis Bacon Act (See Contract Provisions within Original Contract, if applicable); and Copeland Anti-Kickback Act (See Attached Certification, if applicable).

Note: In situations where the Davis-Bacon Act does not apply, neither does the Copeland "Anti-Kickback Act.

4. Contract Work Hours and Safety Standards Act of 1962, 40 U.S.C. 327 et seq.

The Contractor agrees it will require that mechanics and laborers (including watchmen and guards) employed on this federally assisted contract be paid wages of not less than one and one-half times their basic wage rates for all hours worked in excess of forty hours in a work week.

(1) Overtime requirements. No contractor or subcontractor contracting for any part of the contract work which may require or involve the employment of laborers or mechanics shall require or permit any such laborer or mechanic in any workweek in which he or she is employed on such work to work in excess of forty hours in such workweek unless such laborer or mechanic receives compensation at a rate not less than one and one-half times the basic rate of pay for all hours worked in excess of forty hours in such workweek.

(2) Violation; liability for unpaid wages; liquidated damages. In the event of any violation of the clause set forth in paragraph (b)(1) of this section the contractor and any subcontractor responsible therefor shall be liable for the unpaid wages. In addition, such contractor and subcontractor shall be liable to the United States (in the case of work done under contract for the District of Columbia or a territory, to such District or to such territory), for liquidated damages. Such liquidated damages shall be computed with respect to each individual laborer or mechanic, including watchmen and guards, employed in violation of the clause set forth in paragraph (b)(1) of this section, in the sum of \$26 for each calendar day on which such individual was required or permitted to work in excess of the standard workweek of forty hours without payment of the overtime wages required by the clause set forth in paragraph (b)(1) of this section.

(3) Withholding for unpaid wages and liquidated damages. The (write in the name of the Federal agency or the loan or grant recipient) shall upon its own action or upon written request of an authorized representative of the Department of Labor withhold or cause to be withheld, from any moneys payable on account of work performed by the contractor or subcontractor under any such contract or any other Federal contract with the same prime contractor, or any other federally-assisted contract subject to the Contract Work Hours and Safety Standards Act, which is held by the same prime contractor, such sums as may be determined to be necessary to satisfy any liabilities of such contractor or subcontractor for unpaid wages and liquidated damages as provided in the clause set forth in paragraph (b)(2) of this section.

(4) Subcontracts. The contractor or subcontractor shall insert in any subcontracts the clauses set forth in paragraph (b)(1) through (4) of this section and also a clause requiring the subcontractors to include these clauses in any lower tier subcontracts. The prime contractor shall be responsible for compliance by any subcontractor or lower tier subcontractor with the clauses set forth in paragraphs (b)(1) through (4) of this section.

5. Federal Fair Labor Standards Act, 29 U.S.C. Section 201 et seq.

The Contractor agrees it will require that covered employees be paid at least the minimum prescribed wage, and also that they be paid one and one-half times their basic wage rates for all hours worked in excess of the prescribed work-week.

6. Copeland “Anti-Kickback” Act (U.S.C. Section 51)

The Contractor agrees to comply with the Copeland Anti-Kickback Act of 1968, if applicable, which outlaws and prescribes penalties for “kickbacks” of wages in federally financed or assisted construction activities.

7. Reporting

The Contractor will provide any information requested by the District which is determined to be required to comply with 2 C.F.R. § 200 requirements and regulations pertaining to reporting.

8. Patents and Data

No reports, maps, or other documents produced in whole or in part under this contract shall be the subject of an application for copyright by or on behalf of the Contractor. The grantor agency and the grantee shall possess all rights to invention or discovery, as well as rights in data which may arise as a result of the Contractor’s services.

9. Clean Air Act, Federal Water Pollution Control Act, Executive Order 11738, and US EPA Regulations

Contracts and sub grants of amounts in excess of \$100,000 shall contain a provision that requires the Contractor or recipient to comply with all applicable standards, orders, or requirements issued under Section 112 and 306 of the Clean Air Act (42 U.S.C. § 1857 (h)), Section 508 of the Clean Water Act (33 U.S. 1368), Executive Order 11738, and the U.S. Environmental Protection Agency regulations (40 CFR Part 15 and 61). Violations shall be reported to the Federal awarding agency and the Regional Office of the Environmental Protection Agency (EPA).

10. Energy Conservation Requirements - 42 USC 6201

Energy Conservation - The Contractor agrees to comply with mandatory standards and policies relating to energy efficiency, which are contained in the state energy conservation plan issued in compliance with the Energy Policy and Conservation Act.

11. If appropriate to the project, the Contractor will provide assurances regarding the following:

- **Procurement of Recovered Materials.** The requirements of Section 6002 of the Solid Waste Disposal Act, Pub. L. No. 89.272 (1965) (codified as amended by the Resource Conservation and Recovery Act at 42 U.S.C. § 6962. The requirements of 6002 include procuring only items designated in guidelines of EPA 40 C.F.R. Part 247 that contain the highest percentage of recovered materials practicable, consistent with maintaining a satisfactory level of competition, where the purchase price of the item exceeds \$10,000.
 - a) In the performance of this contract, the Contractor shall make maximum use of products containing recovered materials that are EPA-designated items unless the product cannot be acquired –
 - i. Competitively within a timeframe providing for compliance with the contract performance schedule;
 - ii. Meeting contract performance requirements; or
 - iii. At a reasonable price.
 - b) Information about this requirement, along with the list of EPA-designate items, is available at EPA’s Comprehensive Procurement Guidelines website, <https://www.epa.gov/smm/comprehensive-procurement-guideline-cpg-program>.

THE FOLLOWING DOCUMENTS NEED TO BE RETURNED TO THE DISTRICT.

1. Acknowledgement of Terms, Conditions, and Grant Clauses
2. Certification Regarding Lobbying

Acknowledgement of Terms, Conditions, and Grant Clauses

Flow Down of Terms and Conditions from the Grant Agreement

Subcontracts: If the Vendor Subcontracts any of the work required under this Agreement, a copy of the signed Subcontract must be available to the Department for review and approval. The Vendor agrees to include in the Subcontract that (i) the Subcontractor is bound by the terms of this Agreement, (ii) the Subcontractor is bound by all applicable state and federal laws and regulations, and (iii) the Subcontractor shall hold the District harmless against all claims of whatever nature arising out of the Subcontractor's performance of work under this Agreement, to the extent allowed and required by law.

Grant Clauses

On behalf of my firm, I acknowledge, and agree to perform all of the specifications and grant requirements identified in this document.

Vendor/Contractor Name _____ Date _____

Authorized Signature _____

Email Address _____

Address/Phone Number

Contract Number _____

CERTIFICATION REGARDING LOBBYING
(Byrd Anti-Lobbying Amendment, awards over \$100,000)

The undersigned _____ (Vendor/ Contractor) certifies, to the best of his or her knowledge and belief, that:

(1) No Federal appropriated funds have been paid or will be paid, by or on behalf of the undersigned, to any person for influencing or attempting to influence an officer or employee of an agency, a Member of Congress, an officer or employee of Congress, or an employee of a Member of Congress in connection with the awarding of any Federal Contract, the making of any Federal grant, the making of any Federal loan, the entering into of any cooperative agreement, and the extension, continuation, renewal, amendment, or modification of any Federal Contract, grant, loan, or cooperative agreement.

(2) If any funds other than Federal appropriated funds have been paid or will be paid to any person for making lobbying contacts to an officer or employee of any agency, a Member of Congress, an officer or employee of Congress, or an employee of a Member of Congress in connection with this Federal Contract, grant, loan, or cooperative agreement, the undersigned shall complete and submit Standard Form--LLL, "Disclosure Form to Report Lobbying," in accordance with its instructions [as amended by "Government wide Guidance for New Restrictions on Lobbying," 61 Fed. Reg. 1413 (1/19/96). Note: Language in paragraph (2) herein has been modified in accordance with Section 10 of the Lobbying Disclosure Act of 1995 (P.L. 104-65, to be codified at 2 U.S.C. 1601, et seq.)]

(3) The undersigned shall require that the language of this certification be included in the award documents for all sub awards at all tiers (including Subcontracts, sub grants, and Contracts under grants, loans, and cooperative agreements) and that all sub recipients shall certify and disclose accordingly.

This certification is a material representation of fact upon which reliance was placed when this transaction was made or entered into. Submission of this certification is a prerequisite for making or entering into this transaction imposed by 31, U.S.C. § 1352 (as amended by the Lobbying Disclosure Act of 1995). Any person who fails to file the required certification shall be subject to a civil penalty of not less than \$10,000 and not more than \$100,000 for each such failure.

[Note: Pursuant to 31 U.S.C. § 1352(c)(1)-(2)(A), any person who makes a prohibited expenditure or fails to file or amend a required certification or disclosure form shall be subject to a civil penalty of not less than \$10,000 and not more than \$100,000 for each such expenditure or failure.]

The Vendor/Contractor, _____, certifies or affirms the truthfulness and accuracy of each statement of its certification and disclosure, if any. In addition, the Contractor understands and agrees that the provisions of 31 U.S.C. A 3801, et seq., apply to this certification and disclosure, if any.

_____ Signature of Vendor/Contractor's Authorized Official

_____ Name and Title of Vendor/Contractor's Authorized Official

_____ Date

EXHIBIT 2
Disadvantage Business Enterprises
CONTRACT PARTICIPATION FORM

Efforts to Obtain MBE/WBE/LSAF Participation

- A. Please answer the following questions and return this questionnaire with attachments (i.e., ads, meeting attendance list, etc.) to the Purchasing Agent with your offer.

Project Name: _____
Solicitation Number: _____
Contractor: _____

- B. Did your company: YES/NO

1. Attend any pre-proposal meetings that were scheduled by the District? **Yes** No **N/A (provide documentation)**

If YES, please list the meetings (e.g. site-visit, pre-proposal conference, proposal reading) attended below.

- a)
- b)
- c)

2. Did your company utilize the services or assistance, as appropriate, of such organizations as the Small Business Administration, Alaska District Office, the Department of Transportation and Public Facilities (DOT), Civil Rights Office and/or the US Department of Labor?

Yes No **N/A (provide documentation)**

3. Advertise subcontracting opportunities in major circulation newspapers, such as:

- a) Anchorage Daily News?
- b) Pubic Website?
- c) Plans Rooms?
- d) Other types of notices?

Yes No **N/A (provide documentation)**

If YES, please attach copies of any ads or notices.

4. Provide timely written notice to specific MBEs/WBEs/LSAFs that their interest in the contract is being solicited? **Yes** No **N/A (provide documentation)**

If YES, please attach a sample of such notification and list MBEs/WBEs contacted on the Contact Documentation Form (Exhibit 4).

5. Follow-up initial solicitations of interest by personally contacting MBEs/WBEs/LSAFs? **Yes** No **N/A (provide documentation)**

If YES, please list those MBEs/WBEs/LSAFs contacted on the Contact Documentation Form (Exhibit 4).

Exhibit 2
Contract Participation Form

6. Select the portions of the contract to be performed by MBEs/WBEs/LSAFs in a manner that will increase the likelihood of MBE/WBE/LSAF participation? **Yes** No **N/A (provide documentation)**

If YES, please attach a list of those portions of the contract selected for MBE/WBE/LSAF participation.

7. Provide interested MBEs/WBEs/LSAFs with timely and thorough information about the plans, specifications and technical requirements of the contract? **Yes** No **N/A (provide documentation)**

If YES, please list the MBEs/WBEs/LSAFs provided with such information on the Contact Documentation Form (Exhibit 4).

8. Negotiate in good faith with interested MBEs/WBEs/LSAFs, and not reject MBEs/WBEs/LSAFs as unqualified without sound reasons based on a thorough investigation of their capabilities? **Yes** No **N/A (provide documentation)**

If YES, list MBEs/WBEs/LSAFs with whom good faith negotiations were conducted on the Contact Documentation Form (Exhibit 4).

9. Assist interested MBEs/WBEs/LSAFs in obtaining bonding and/or insurance. **Yes** No **N/A (provide documentation)**

If YES, list MBEs/WBEs/LSAFs assisted on the Contact Documentation Form (Exhibit 4).

10. For each question answered "YES" above that requires a listing of MBEs/WBEs/LSAFs, please provide that listing on this page. Answers need not be limited to a single line. If more space is needed, please attach supplemental sheets. You need only list an MBE/WBE/LSA firm only once. Use the first column to indicate the question(s) referenced above by each firm listed. Any question answered "N/A" above, please provide supporting documentation of good faith efforts taken.

EXHIBIT 3
Disadvantaged Business Enterprises
PRIME CONSULTANT/CONTRACTOR CERTIFICATION

I. PROJECT INFORMATION

Applicant/Entity Name	Total of District Funding
Anchorage School District	\$

Prime Consultant/Contractor: _____
Contract Number: _____ **Contract Amount:** _____

II. AFFIRMATIVE STEPS (Applicant to all subcontracts awarded by the prime consultant/contractor)

I understand that it is my responsibility to comply with all state and federal regulations and guidance in the utilization of Minority, Women-Owned Businesses and Labor Surplus Area Firms in procurement. I certify that I will take affirmative steps to afford opportunities for Minority Business Enterprise (MBE), Women-Owned Business Enterprise (WBE) and Labor Surplus Area Firms (LSAF) by:

1. Including qualified MBEs/WBEs/LSAFs on procurement solicitation lists
 2. Soliciting potential MBE's/WBE's/LSAFs.
 3. Reducing contract size/quantities when economically feasible to permit maximum participation by MBE's/WBE's/LSAFs.
 4. Establishing delivery schedules to encourage participation by MBE's/WBE's/LSAFs.
 5. Using the services and assistance of the Small Business Administration, Minority Business Development Agency, U.S. Department of Commerce (<https://www.sba.gov/>), as appropriate, the Department of Transportation and Public Facilities (DOT), Civil Rights Office (<http://www.dot.state.ak.us/cvlrts/directory.shtml>) and/or the US Department of Labor (<http://www.doleta.gov/lssa>).
 6. Requiring all Prime Consultants/Contractors to follow steps 1-5 listed above in employing MBE/WBE/LSA Subcontractors.
- Exception:** As Prime Consultant/Contractor, I certify that I have reviewed the contract requirements and found no available subcontracting opportunities. I also certify that I will fulfill 100 percent of the contract requirements with my own employees and resources. (Check if applicable).

Signature – Prime Consultant/Contractor	Name & Title (print legibly)	Certification Date

III. DISTRICT APPROVAL SIGNATURE

Signature indicates the form meets DBE Requirements.

District Coordinator	Approval Date

EXHIBIT 4
Disadvantaged Business Enterprises
CONTACT DOCUMENTATION FORM

Project Name: _____ RFQ/ITB/RFP No. _____

Company Name: _____

This form is provided for your convenience to document your efforts to meet the DBE Affirmative Steps on this project. You may use additional sheets, if needed. You may return this form or other supporting documentation, such as explanations, advertising notices, solicitations, telephone logs, etc. with your Contract Participation Form (Exhibit 3).

Firm: _____ MBE / WBE / LSAF

Address: _____ Phone No: _____

Type of Work: _____ Amount: \$ _____

Dates of Contact: _____

Method of Contact: _____

Name of Person Contacted: _____

Results of Contact: _____

If rejected, why: _____

Firm: _____ MBE / WBE / LSAF

Address: _____ Phone No: _____

Type of Work: _____ Amount: \$ _____

Dates of Contact: _____

Method of Contact: _____

Name of Person Contacted: _____

Results of Contact: _____

If rejected, why: _____

Firm: _____ MBE / WBE / LSAF

Address: _____ Phone No: _____

Type of Work: _____ Amount: \$ _____

Dates of Contact: _____

Method of Contact: _____

Name of Person Contacted: _____

Results of Contact: _____

If rejected, why: _____

**Disadvantaged Business Enterprise Program (DBE)
Program Specifications for District Contracts**

This project is a Federally funded contract and, is subject to any applicable federal and state regulations. Bidders/proposers shall be fully informed regarding the requirements of the regulations, statutes, and code regarding the Disadvantaged Business Enterprise Program (DBE).

A bidder/proposer who is determined not in compliance with the requirements of the applicable regulations and code, or these specifications will not be awarded this contract. Noncompliance after award of the contract constitutes a breach of the contract and may result in termination of the contract or other appropriate remedy for such breach.

Part I. Disadvantaged Business Enterprise Program Goals and Six Affirmative Steps.

All bidders/proposers shall solicit subcontractor or supplier bids/offers prior to bid/proposal opening for this project. The bidder/proposer acknowledges that post-bid/proposal opening of solicitations do not qualify for meeting Fair Share objectives or the Six Affirmative Steps.

- A. All bidders/proposers on this project **shall** carry out the required Six Affirmative Steps, listed as items 1 through 6 below:
1. Include qualified small, minority, women's business enterprises, and labor surplus area firms on solicitation lists.
 2. Assure that small, minority, women's business enterprises, and labor surplus area firms are solicited. If the MBE/WBE is only certified as a Disadvantaged Business Enterprise (DBE), such as through the Small Business Administration (SBA), Alaska District Office; and the Alaska Department of Transportation and Public Facilities (DOT&PF), Civil Rights Office, and the bidder has exhausted all efforts to determine the subcontractor MBE/WBE status, the bidder may document either category of certification to meet the good faith efforts.
 3. Divide total requirements when economically feasible, into small tasks or quantities to permit maximum participation of small, minority, women's business enterprises, and labor surplus area firms.
 4. Establish delivery schedules, where requirements of the work permit, which will encourage participation by small, minority, women's business enterprises, and labor surplus area firms.
 5. Use the services and assistance of the U.S. Small Business Administration and the Minority Business Development Agency of the U.S. Department of Commerce, as appropriate.
 6. If the prime contractor or proposer awards subcontracts/procurements, require the subcontractor to take the affirmative steps 1 through 5 above.
 7. Exception: As prime consultant/contractor, certify that they have reviewed the contract requirements and found no available subcontracting opportunities; and certify that they will fulfill 100 percent of the contract requirements with their own employees and resources.
- B. The District will presume a lack of six affirmative steps to satisfy MBE, WBE and LSAF requirements if the bidder/proposer rejects any bids/offers from MBEs, WBEs and/or LSAF's, which are as low, or lower, than other competitor's bids/offers. The bidder/proposer that rejects an as-low or lower bid/offer from an MBE, WBE or LSAF may submit proof to rebut this presumption.
- C. If a prime contractor is an MBE, WBE or LSAF, such prime also must carry out the Six Affirmative Steps to award any subcontracts or procurements on this project.

- D. Record keeping requirements. The prime contractor must retain all records documenting their Six Affirmative Step for audit purposes and provide copies of these to the District DBE Officer upon request.

Apparent successful bidders/proposers, who fail to demonstrate completion of the required Six Affirmative Steps, will not be awarded this contract.

Part II: Certified Minority (MBE) and Women's (WBE) Business Enterprises

- A. MBE/WBE, or a joint-venture with a MBE/WBE, must be currently certified prior to opening of bids/proposals in order to be considered a MBE/WBE enterprise.
- B. Businesses must be certified by the Small Business Administration (SBA), Alaska District Office <https://www.sba.gov/offices/district/ak/anchorage>, Department of Transportation and Public Facilities (DOT), Civil Rights Office <http://www.dot.state.ak.us/cv/rts/directory.shtml>, or by state, local, Tribal or private entities whose certification criteria and who present proof of this will be eligible. Proof may be in the form of a letter from the certifying agency or a current listing in a directory maintained by the certifying agency.
- C. Those companies certified as DBEs by one of the agencies listed in Part II.B above:
1. Whose majority ownership and control is vested in one or more minority individuals;
 2. Whose majority ownership and control is vested in one or more non-minority women;
 3. Whose majority ownership and control is vested in one or more minority individuals, and who are women may be counted toward either the MBE or the WBE, but not to both.

Part III: MBE and WBE Participation

The MBE or WBE must perform work on the project in the category/categories of work for which certification is issued. While the MBE or WBE may perform work in other categories for which certification is not issued, only that work performed in the certified categories.

- A. The MBE or WBE must perform a useful business function according to custom and practice in the industry; i.e., must be responsible for the execution of a distinct element of work and must carry out its responsibilities by actually performing, managing, and supervising the work.
- B. An MBE or WBE that acts merely as a broker or passive conduit of funds, without performing, managing, or supervising the work of its contract or subcontract in a manner consistent with normal business practices.
1. Presumption. If 50% or more of the total dollar amount of MBE or WBE's prime contract is subcontracted to a non-DBE, the MBE or WBE prime contractor will be presumed to be a broker, and no MBE or WBE participation may be reported.
 2. Rebuttal. The MBE or WBE prime contractor may rebut this presumption by demonstrating that its actions are consistent with normal practices for prime contractors in its business and that it will actively perform, manage and supervise the work under this contract.

- C. MBE or WBE trucker/hauler expenditures will be credited towards the contract only if the trucker/hauler is performing a commercially useful function. The following factors should be used in determining whether MBE or WBE trucker/hauler is performing a commercially useful function:
 - 1. The MBE or WBE must be responsible for the management and supervision of the entire trucking/hauling operation for which it is responsible on a particular contract, and there cannot be a contrived arrangement for the purpose of meeting MBE or WBE objectives.
 - 2. The MBE or WBE must itself own and operate at least one fully licensed, insured, and operational truck used on the contract.
- D. For joint ventures, MBE and WBE participation consists of the portion of the dollar amount of the joint venture attributable to the MBE or WBE. However, where the MBE/WBE's risk of loss, control or management responsibilities are not commensurate with the share of profit.

Part IV: Submission of Minority, Women's Business Enterprises and Labor Surplus Area Firms Information

- A. TO BE SUBMITTED AS PART OF BID/PROPOSAL OR WITHIN THREE (3) WORKING DAYS OF NOTICE FROM THE DISTRICT (ASD):
 - 1. The bidder/proposer for this project shall submit their Contact Documentation (Exhibit 4), a completed and signed Prime Consultant/Contractor Certification (Exhibit 3) with their bid/proposal. If the bidder does not intend to utilize MBE, WBE or LSAF subcontractors, their Prime Consultant/Contractor Certification form must still be signed by bidder and, indicate "NONE TO BE USED". The bidder/proposal shall then be required to show that the mandatory Six Affirmative Steps were taken as set forth in these specifications, which are also included in the Contract Participation Form (Exhibit 2).
 - 2. Bids/offers submitted without a completed and signed Contract Participation Form, completed and signed Prime Consultant/Contractor Certification Form, and sufficient Contact Documentation will be considered non-responsive, if not submitted with bid/offer or upon three (3) working days upon request, if not submitted with their bid/proposal.
 - 3. A contract may not be awarded to a bidder/proposer who fails to submit the required supporting documents within the time specified. There shall be no substitutions, deletions, additions, or modifications to this listing subsequent to its submittal to Purchasing.

Part V: MBE/WBE/LSAF Utilization Removal/Substitution

If a successful bidder/proposer for a contract which contains MBE, WBE and/or LSA Firm participation requirements, at any time after award of contract, proposes to remove or make substitutions for MBE, WBE or LSA Firm subcontractors or joint-venture partners under the contract, a written notice of such removal or substitution shall be submitted to the District DBE Officer prior to commencement of performance of the affected work, with the names, addresses and phone numbers of the subcontractors or joint venture partners to be removed or substituted for and an explanation of the reasons for the removal and substitution. The successful bidder shall make good faith efforts as defined in Part I.B to utilize another MBE, WBE or LSA Firm subcontractor as the replacement. These efforts shall be documented and, the circumstances fully explained in writing, and approval obtained from the District DBE Officer prior to such replacement. The District DBE Officer shall, within seven (7) days of receipt of such notice, approve said notice or removal and substitution where it is shown that the requested action is for good cause and not for discriminatory purposes.

Part VI: Other Provisions

The District DBE Officer or his or her designee may visit the job site during regular working hours and interview subcontractors and employees for verification of compliance with these specifications and/or the regulations.

Part VII: Definitions

- A. Minority Business Enterprise (MBE) or Women Owned Business Enterprise (WBE) - means a business concern which is owned and controlled by one or more minorities or women. Owned and controlled means a business:
1. Which is at least 51 percent owned by one or more minorities or women, or in the case of a publicly owned business, at least 51% of the stock is owned by one or more minorities or women;
 2. Whose management and daily business operations are controlled by one or more such individuals.
- B. Minority Individual - means an individual who is a citizen or lawful permanent resident of the United States and who is:
1. Black (a person having origins in any of the black racial groups in Africa);
 2. Hispanic (a person of Mexican, Puerto Rican, Cuban, Central or South American, or other Spanish culture or origin, regardless of race);
 3. Portuguese (a person of Portugal, Brazilian, or other Portuguese culture or origin, regardless of race);
 4. Asian American (a person having origins in any of the original peoples of the Far East, Southeast Asia, the Indian subcontinent, or the Pacific Islands);
 5. American Indian and Alaskan Native (a person having origins in any of the original peoples of North America or original peoples of Alaska), and
 6. Members of other groups, or other individuals, found to be economically and socially disadvantaged by the United States Small Business Administration under section 8(1) of the federal Small Business Act.
- C. Labor Surplus Area (LSA) – is defined as a civil jurisdiction (a city of more than 25,000 or a county, borough, or census area) that has a civilian average annual unemployment rate during the previous two (2) calendar years of 20 percent or more above the average annual civilian unemployment rate for all states during the same 24-month reference period. If the national annual average unemployment rate during the referenced period is less than 6.0 percent, then the qualifying rate is 6.0 percent. If the national annual average unemployment rate during the referenced period is above 10 percent, then the qualifying rate is 10 percent. Please reference the US Department of Labor, Employment and Training Administration at <http://www.doleta.gov/lsa>. The list becomes effective each October 1 and remains in effect through the following September 30.
- D. Certification – a copy of a current MBE/WBE certification from any agency to be used for the District's monitoring of MBE/WBE participation in its program.

- E. Joint Venture – a commercial enterprise undertaken by more than one business enterprise jointly, limited in its scope and duration to one project, for the purpose of each enterprises profiting thereby.
- F. Fair Share - is a reasonable amount of funds commensurate with the total project funding, demographic factors and the availability of minority and women’s businesses. A fair share does not constitute an absolute requirement, but a commitment on the part of the bidder/proposer to attempt to use minority and women’s businesses by carrying out the “Good Faith Efforts”.

For more information about these specifications, please contact the District DBE Officer at the Anchorage School District, Purchasing Warehouse, 4919 Van Buren Street, Anchorage, AK 99517; telephone (907) 742-8630.

Part VIII – Equal Opportunity, Minority, Women-Owned Business Enterprise and Labor Surplus Area Firm (MBE/WBE/LSAF) Participation

A. Equal Opportunity

No person or firm shall be discriminated against because of race, color, national origin, or sex in the award of District contracts. Further, the Contractor shall not discriminate on the basis of race, color, national origin, or sex in the performance of this contract.

B. MBE/WBE Participation

While there are no MBE/WBE/LSAF goals associated with this solicitation, the District is committed to achieving participation in its contracting programs by business enterprises that are owned and operated by minorities, women and labor surplus area firms (MBEs, WBEs and LSAF) regardless of the size of the enterprise. All bidders/offerors are strongly encouraged to take active steps to maximize the participation of MBEs, WBEs and LSAF in this contract.

C. Technical Assistance

The District will provide assistance to promote the participation of MBEs, WBEs and LSAF in this contract, including the identification of MBEs, WBEs and LSAF. To obtain assistance, interested parties are encouraged to contact the District’s Purchasing Office at (907) 742-8621.