



ANCHORAGE SCHOOL DISTRICT

Purchasing Department
4919 Van Buren Street
Anchorage, AK 99517-3137

REQUEST FOR PROPOSAL

THIS IS NOT AN ORDER

Show the following on the outside of the sealed proposal envelope:
RFP 2025-617 DESIGN SERVICES FOR REPLACEMENT OF TWO SCHOOLS GENERATORS

ISSUED DATE:
June 12, 2025

DUE: **Prior to 10:00 a.m., Local Time**
DATE: **July 8, 2025**

The Anchorage School District (referred to as the “District” or the “ASD”) invites sealed proposals from qualified persons/firms to **DESIGN A REPLACEMENT GENERATOR FOR BEAR VALLEY ELEMENTARY SCHOOL AND A NEW GENERATOR INSTALLATION AT NORTH STAR ELEMENTARY SCHOOL** to the District in accordance with the following documents that are a part of this RFP 2025-617:

Cover Page	This Notice/Cover Page	Page(s) 1 – 2
Section I	Instructions to Offerors	Page(s) 3 – 13
Section II	Evaluation of Proposals	Page(s) 14 – 15
Section III	Proposal Format	Page(s) 16 – 17
Section IV	Specifications and Scope of Services	Page(s) 18 – 22
Attachment A	Proposal Transmittal Form	1 Page(s)
Attachment B	Sample Professional Services Agreement (PSA)	5 Page(s)
Attachment C	Bear Valley ES Site Plan	1 Page(s)
Attachment D	North Star ES Site Plan	1 Page(s)
Attachment E	Offeror’s Checklist	1 Page(s)
Exhibit 1	Supplemental Terms, Conditions and Forms	7 Page(s)
Exhibit 2	Disadvantaged Business Enterprises Contract Participation Form	2 Page(s)
Exhibit 3	Disadvantaged Business Enterprises Prime Consultant/Contractor Certification	1 Page(s)
Exhibit 4	Disadvantaged Business Enterprises Contact Documentation Form	1 Page(s)
Special Provisions	Disadvantaged Business Enterprise Program Program Specifications for District Contracts	5 Page(s)

THIS RFP HAS FEDERAL GRANT REQUIREMENTS (DISADVANTAGED BUSINESS ENTERPRISE (DBE) PROGRAM PARTICIPATION REQUIREMENTS).

DBE PARTICIPATION REQUIREMENTS MUST BE COMPLETED BY THE PROPOSAL SUBMISSION DATE.

AVAILABILITY OF RFP: This Request for Proposals (.pdf) is available electronically at the District’s Purchasing website: <http://asdk12.org/depts/purchasing/>

A copy of the current plan holder’s list can be viewed at:
http://apps.asdk12.org/depts/purchasing/meeting/Plan_Holders/2025/617.xlsx

SUBMISSION OF PROPOSALS: Proposals must be submitted to the Anchorage School District Purchasing Department, 4919 Van Buren Street, Anchorage, Alaska 99517-3137 prior to the time specified above. Proposals received after that time will not be considered and will be returned. FAXED or ELECTRONIC proposals are not acceptable. Proposals must be submitted in a SEALED package with the outside of the package clearly marked with Offeror’s name, address, and phone number, and as follows:

REQUEST FOR PROPOSALS 2025-617
DESIGN SERVICES FOR REPLACEMENT OF TWO SCHOOLS GENERATORS
DUE: Prior to 10:00 a.m., Local Time
DATE: July 8, 2025

PRE-PROPOSAL SITE-VISIT: **A pre-proposal site-visit will be held at 10:30 a.m., Local Time, June 17, 2025**, at Bear Valley Elementary School, 15001 Mountain Air Dr. from there the group will move to North Star Elementary School, 605 W. Fireweed Ln. Prospective proposers are encouraged to meet the ASD Project Manager at the School’s main office entrance and walk through the proposed area of design for this RFP.

PRE-PROPOSAL CONFERENCE: **A pre-proposal conference will be held at 10:00 a.m., Local Time, June 18, 2025**, in the conference room of the Anchorage School District Purchasing Department, 4919 Van Buren Street, Anchorage, Alaska to discuss any matter concerned with this RFP. Prospective Offerors are encouraged to participate by teleconference by calling (907) 742-6750. The line will be available approximately 5 minutes’ prior the conference start time.

The Anchorage School District is committed to providing reasonable accommodations, according to applicable state and federal laws, to all individuals with a qualifying disability. If you require a reasonable accommodation in order to participate in this or any other district process, please contact the Anchorage School District's Compliance/Equal Employment Opportunity Office (907) 742-4132.

Estimated amount of proposed contracts: Under \$100,000

END OF COVER PAGE

A. GENERAL REQUIREMENTS

This solicitation is a REQUEST FOR PROPOSALS (“RFP”) governed by applicable Anchorage School Board Policies, including Section 3311 of such Policies. Anchorage School Board Policies are available at <https://www.boardpolicyonline.com/?b=anchorage>

Offerors should read this RFP carefully and review all instructions contained herein. Incomplete or incorrect proposals may be rejected as not conforming to the essential requirements of the RFP. Proposals submitted on other than the prescribed forms contained in this RFP will be rejected. Offerors may copy the forms contained in the RFP for use in their proposals, but substitute forms or formats are unacceptable. Electronic copies of the forms which offerors must submit as part of any proposal, if any—if not provided with this RFP—may be obtained by contacting the Anchorage School District Purchasing Department. Forms shall not be altered except to supply requested offeror information.

B. INTENT OF SPECIFICATIONS

The Anchorage School District desires to enter into a contract with an offeror whose primary business is to provide professional design services for the installation of a new and replacement generators at two schools, and to complete the contract in accordance with all of its terms and conditions and in compliance with all applicable laws. The scope of work is considered performance oriented and it is the intent of the District to rely on the experience and expertise of the offeror to fully appraise itself of the work required to fulfill the terms of the contract resulting from the RFP.

C. EXAMINATION OF CONTRACT DOCUMENTS

Offerors should read this Request for Proposals carefully and review all instructions contained herein. The submission of a proposal shall constitute acknowledgement that the offeror has thoroughly examined and is familiar with the solicitation documents.

D. CONDITIONS OF THE WORK

Each offeror must acquaint itself thoroughly as to the character and nature of the services to be provided to fulfill the requirements of the resulting contract. Each offeror must complete a careful examination of the existing systems, infrastructure, geographical features, and prevailing weather conditions, as applicable, and must inform itself fully as to the difficulties to be encountered in the performance of the work, the availability of a qualified work force and other conditions related to providing the required services. No claim of ignorance of conditions that exist or hereafter may exist, or difficulties that may be encountered in the execution of the work, as a result of failures to make necessary investigations and examinations, will be accepted as an excuse for any failure or omission on the part of a successful offeror(s) to fulfill all of the requirements of the contract documents and to complete the work for the consideration set forth therein, or as the basis for any claim whatsoever.

E. QUESTIONS; METHOD FOR CLARIFICATION

Any offeror in doubt as to the true meaning of any part of this RFP may submit to the District a written request for an interpretation thereof. Questions must be received by the District’s Purchasing Department at least seven (7) days prior to the date set for the submission of proposals. If such date falls on a weekend or holiday, the deadline shall be the last business day before the weekend or holiday. Questions can be delivered as follows:

Fax: Anchorage School District Purchasing Department @ 907-243-6293
Attn: Shannon Powers, Sr. Purchasing Agent
Reference: RFP 2025-617 DESIGN SERVICES FOR REPLACEMENT OF TWO SCHOOLS GENERATORS

E-mail: purchasing@asdk12.org **PREFERRED METHOD**
Attn: Shannon Powers, Sr. Purchasing Agent
Reference: **RFP 2025-617 DESIGN SERVICES FOR REPLACEMENT OF TWO SCHOOLS GENERATORS**

Mail: Anchorage School District Purchasing Department
Attn: Shannon Powers, Sr. Purchasing Agent
4919 Van Buren Street
Anchorage Alaska 99517-3137
Reference: RFP 2025-617 DESIGN SERVICES FOR REPLACEMENT OF TWO SCHOOLS GENERATORS

Two types of questions generally arise. One may be answered by directing the offeror to a specific section of the RFP. These questions may be answered by direct communication to the offeror submitting the question. Questions which in the opinion of the Purchasing Senior Director require a more detailed or complex reply, or require an answer that may affect responses to this RFP or may be prejudicial to other prospective offerors, will be answered by issuing an addendum to all RFP holders prior to the submittal opening.

F. ERRORS AND AMBIGUITIES

1. Offeror comments concerning discrepancies, defects, ambiguities or other errors in the RFP must be made in writing and received by the District's Purchasing Department at least seven (7) days prior to the date set for the submission of proposals. If such date falls on a weekend or holiday, the deadline shall be the last business day before the weekend or holiday. Comments can be delivered as set forth in Section E, above. Any clarifications, changes or corrections to the RFP will be made only by written notice or addendum issued by the District.
2. If an offeror fails to notify the District of a discrepancy, defect, ambiguity or other error in the RFP, the offeror's proposal shall be submitted at the offeror's own risk and if a contract is awarded as a result of such proposal, the offeror shall not be entitled to additional compensation or other consideration by reason of the discrepancy, defect, ambiguity or other error, or its later correction or clarification. Protests based on any error or omission, or on the content of the solicitation, will be disallowed if the fault has not been brought to the attention of the District, in writing, at least five (5) days prior to the date set for submission of proposals. If such date falls on a weekend or holiday, the deadline shall be the last business day before the weekend or holiday.

G. ADDENDA

Addenda may be issued when changes, clarifications, or amendments to this RFP are deemed necessary by the District for any reason. If an addendum is issued, the District will make reasonable efforts to ensure that each prospective offeror receives the addendum in a timely fashion. However, the risk of non-receipt of any addendum lies solely with prospective offerors. Offerors should contact the District at the addresses set forth in Section E, above, to ascertain if any addenda have been issued. Offerors must acknowledge receipt of each addendum issued in the space provided on the appropriate addendum form and submit such signed addendum with the proposal. No oral change or interpretation of this RFP shall be relied upon by prospective offerors or shall be binding on the District whether issued at a pre-proposal conference or otherwise.

H. SUBMISSION OF PROPOSALS

1. All proposals, addenda, and forms must be manually signed. **One (1) original and three (3) copies of the proposal, for a total of four (4). Submit the above per Site.**

2. Proposals delivered by telefax, facsimile or by electronic means are not acceptable and will not be considered.
3. Signed and sealed Proposals must be at the District Purchasing Department on or before the time and date stated on the face page of this RFP. Offerors are solely responsible for ensuring that the offeror's proposal package is received by the District's Purchasing Department by the deadline.
4. Late proposals will not be considered and will be returned to the offeror unopened.
5. Photographs may be included with a proposal as appropriate or as desired by the offeror. Photographs will not be returned to an offeror.
6. Offerors may submit only one proposal for evaluation.
7. No responsibility will attach to any officer or agent of the District for the premature opening of, or the failure to open, a proposal not properly addressed and identified.

I. ALASKA BUSINESS LICENSE

Offerors must hold a valid Alaska business license and any necessary applicable professional licenses required by Alaska Statute as a condition of award. Offerors should contact the State of Alaska, Department of Commerce, Community and Economic Development, Division of Occupational Licensing, for information regarding business licensing. Contact information, information regarding business licensing, and business licenses, are available at <https://www.commerce.alaska.gov/web/>.

J. FIRM OFFER

Offers made in response to this RFP must be good and firm for a period of ninety (90) calendar days from the date specified for submittal of proposals.

K. WITHDRAWAL OF PROPOSALS

Proposals may be withdrawn on written request delivered to the District Purchasing Director (fax is acceptable) prior to the time specified for submittal. Proposals not withdrawn prior to the specified time may not be withdrawn for a period of ninety (90) calendar days after the time for receipt of proposals.

L. DISTRICT NOT RESPONSIBLE FOR PREPARATION COSTS

Each offeror understands and agrees that it submits its proposal at its own risk and expense and releases the District from any claim for damages or other liability arising out of the Request for Proposals and award process, including but not limited to: proposal preparation costs and costs associated with any challenge (administrative, judicial or otherwise (including attorney fees)) to the determination of the highest ranked proposal and/or award of contract and/or rejection of proposals, except as follows: in the event that a contract is awarded to one offeror, and it is determined after award of the contract that it should have been awarded to some other offeror, the only financial liability of the District, if any, to the aggrieved offeror shall be actual costs reasonably incurred by that offeror in the preparation and submittal of its proposal. No other obligation of any sort is created nor may liability, financial or otherwise, be asserted against the District, its Board, Board members, employees, agents or insurers to offer to award or award a contract. By submitting a proposal, each offeror agrees to be bound in this respect.

M. REJECTION OF PROPOSALS

1. Offerors must comply with all of the terms of this RFP, and all applicable local, state, and federal laws, codes and regulations. The District may reject any proposal that does not comply with all of the material and substantial terms, conditions, and performance requirements of this RFP and any proposal which contains information or material which cannot be verified or otherwise confirmed for purposes of determining responsiveness to the solicitation.
2. The District reserves the right to waive informalities and minor irregularities, and/or reject any and all proposals, and to not award the proposed contract, if in its best interest. "Informalities and minor irregularities" means matters of form rather than substance which are evident from the submittal, or are insignificant matters that have a negligible effect on price, quantity, quality, delivery, or contractual conditions and that can be waived or corrected without prejudice to other Offerors. These include items that:
 - Do not affect responsiveness;
 - Are merely a matter of form or format;
 - Do not change the relative standing or otherwise prejudice other offers;
 - Do not change the meaning or scope of the RFP;
 - Are trivial, negligible, or immaterial in nature;
 - Do not reflect a material change in the work, or;
 - Do not constitute a substantial reservation against a requirement or provision of the RFP.

N. SELECTION FOR AWARD

1. Selection for award will be accomplished in accordance with Anchorage School Board Policy Section 3311 and the terms and conditions of this solicitation. A recommendation for award, based upon the evaluation criteria specified in this RFP, will be made to the Anchorage School Board for approval, unless approval is not required under Board Policy Section 3311.
2. The District may award a contract on the basis of initial proposals received, without discussions. Therefore, each proposal should contain the offeror's best efforts from a technical standpoint.
3. For those awards requiring Board approval, the District's Purchasing Department will make public in the Purchasing Department each Notice of Intent to Award ten (10) calendar days prior to the scheduled date for award by the Board. Offerors may, upon request to the Purchasing Department, review the proposal scoring summary prior to the scheduled Board award date.
4. Any contract awarded as a result of this solicitation will incorporate the contents of this RFP and the successful offeror's proposal, subject to the reservations set forth herein for provisions of a proposal that do not comply with material and substantial terms, conditions, and requirements of this RFP or that impermissibly restrict the rights of the District. The successful offeror(s) will be required to execute a written contract in the form included as part of this RFP and comply with its terms.

O. NEGOTIATIONS

After final evaluation, the District may negotiate with the offeror of the highest-ranking proposal. Negotiations, if held, shall be within the scope of the RFP and limited to those items which would not have an effect on the ranking of proposals. The District reserves the right to change terms and conditions during contract negotiations. If the highest-ranked offeror fails to provide necessary information for negotiations in a timely manner or fails to negotiate in good faith, or if the offeror and the District, after a good faith effort, cannot come to terms, the District may terminate negotiations and commence negotiations with the offeror of the next highest-ranking proposal.

P. RESPONSIBLE OFFERORS

1. A contract will be awarded only to prospective offerors who are determined to be responsible.
2. In order to determine responsibility of a prospective offeror, the District may require offerors to supply additional information or documentation and may perform on-site pre-award surveys. Failure of an offeror to promptly cooperate or supply information in connection with a District inquiry with respect to responsibility may result in a determination of non-responsibility with respect to the offeror.
3. To be determined responsible, a prospective offeror must:
 - a. Have adequate financial resources to perform the contract or the ability to obtain them;
 - b. Be able to comply with the contract performance schedule taking into consideration all existing other business commitments;
 - c. Have a satisfactory performance record;
 - d. Have a satisfactory record of integrity and business ethics;
 - e. Have the necessary organization personnel, experience, accounting and operational controls, and technical skills, or the ability to obtain them;
 - f. Have the necessary equipment and facilities or the ability to obtain them; and
 - g. Be otherwise qualified and eligible to receive an award under applicable laws and regulations.

Q. AWARD OF CONTRACT

1. Award of Contract
 - a. The District may select up to two (2) firms from the highest ranked proposals per Site for award.
 - b. Selection of the successful offeror will be by a notice in writing signed by a duly authorized representative of the District and no other act of the District or its representative will constitute an acceptance of a proposal.
2. Execution of Contract
 - a. The offeror whose proposal is accepted by the District shall execute the contract and furnish the required insurance within five (5) days after presentation of the contract for signature. Failure or neglect to provide the required insurance or to execute the contract within the time specified, or within such additional time as the District, in its sole discretion, may allow, shall constitute a breach of the agreement affecting the award. The damages to the District for such breach shall include loss due to delay and interference with the District's general operations improvements program, and increased administrative expense, and other items whose accurate amount would be difficult or impossible to compute.
 - b. Upon receipt of the above-referenced contract executed by the offeror, and all required insurance certificates, the properly authorized District representatives will execute the

contract. The Contract shall not be effective until it is executed by a properly authorized representative of the District.

R. AGGRIEVED OFFERORS

1. Protest

- a. An interested party may protest a solicitation or a proposed award of a contract.
 - i. A protest as to the specifications and/or terms and conditions of a solicitation must be received by the Purchasing Senior Director at least five (5) calendar days prior to the due date of the bid or proposal; failure to protest as provided herein constitutes a waiver of any objection to the solicitation.
 - ii. For construction projects and architectural/engineering design services, the protest of a proposed award of a contract must be received by the Purchasing Senior Director within ten (10) calendar days after issuance of the Notice of Intent to Award.
 - iii. For goods or services, the protest of a proposed award of a contract must be received by the Purchasing Senior Director within seven (7) calendar days after issuance of the Notice of Intent to Award, except that for purchases under \$100,000, the protest must be received within three (3) business days.
 - iv. The protest must include the name of the person submitting the protest, the name of the bidder/proposer represented by that person, the specific action or bid/request for proposal contract award which is being protested, a detailed explanation of the reasons for the protest, and the relief requested.
 - v. The aggrieved person must serve all other interested parties with its protest.
- b. The Purchasing Senior Director shall stay the intended award of a contract unless the Purchasing Senior Director determines the award of the contract without further delay is necessary to protect the District's best interest.
- c. The Purchasing Senior Director may, in his/her sole discretion, hold a hearing.
- d. The rights and remedies granted by this section are not available for informal small purchases with an actual or potential value of less than twenty-five thousand dollars (\$25,000).
- e. Failure to protest as provided herein constitutes a waiver of any objection to the solicitation and contract award.

2. Appeal

- a. A decision by the Purchasing Senior Director may be appealed to the Anchorage School Board.
- b. Any appeal shall be filed with the Superintendent within five (5) days after the decision is received by the protester and must include the name of the person submitting the appeal, the name of the bidder/proposer represented by that person, and a detailed explanation of the basis for the appeal.
- c. The aggrieved bidder/proposer must serve all other interested parties with its appeal.

- d. The Superintendent may obtain an independent review of the appeal issues if the Superintendent determines such review will assist consideration of the appeal.
 - e. The independent review shall not be conducted by a District employee, but must be conducted by an experienced but disinterested third party from outside the District.
 - f. Failure to appeal to the Anchorage School Board as provided herein constitutes a waiver of any objections to the solicitation and the contract award.
3. Consideration of Appeal
- a. The decision being appealed and the findings from the independent review, if any will be reported to the Board.
 - b. Upon consideration of the appeal and allowing interested parties an opportunity to address the issues on appeal, the Board may:
 - i. Award the contract as recommended, if applicable, indicating its reasons for rejecting the appeal;
 - ii. Grant the appeal, indicating its reasons for granting the appeal, and determine an appropriate remedy consistent with AR3311.1(c).1 of Board Policy. The Board may award the contract at that meeting to some other bidder/proposer if it finds that a delay in making the award would adversely affect the District.
 - iii. Stay any award of the contract to permit further consideration of the appeal, with action to be scheduled as soon as practicable, but in no event more than twenty (20) days after the stay as initiated.
 - iv. Reject all bids/proposals
 - v. Take such other action as appears appropriate and in the best interest of the District under the circumstances.
4. Frivolous Protests
- a. Signature on Protest Constitutes Certificate
 - i. The signature of an attorney or party on a request for review, protest, motion, or other document constitutes a certificate by the signer that the signer has read the document, to the best of his/her knowledge, information, and belief formed after reasonable inquiry it is well grounded in fact and is warranted by existing law or a good faith argument for the extension, modification, or reversal of existing law, and that it is not interposed for an improper purpose, such as to harass, limit competition, or to cause unnecessary delay or needless increase in the cost of the procurement or of the litigation.
 - b. Sanctions for Violation
 - i. If a request for review, protest, pleading, motion, or other document is filed with the Purchasing Senior Director is signed in violation of Board Policy AR3311.1(c).1, the School Board may impose upon the person who signed it, a represented party, or both, an appropriate sanction, that may include an order to pay to the other party or parties the amount of the reasonable expenses incurred because of the filing of the protest, pleading, motion, or other paper, including a reasonable attorney's fee.

S. PUBLIC RECORDS/CONFIDENTIALITY

1. This RFP and the resulting proposals received, together with copies of all documents pertaining to the award of a contract, will be kept by the District's Purchasing Office and made a part of the record which will be open to public inspection after contract award. Proposers, upon request to the Purchasing Officer, may review the proposal scoring summary after issuance of the notice of intent to award has been issued, except to the extent permissibly restricted by the offeror.
2. Offerors are advised to consult School Board Policy Section 1340 and the Alaska Public Records Act, A.S. 40.25.100-40.25.295 to verify if any of their proposal information may qualify for exemption from public disclosure. Exemptions to public disclosure requirements are narrowly construed. As such, the District cannot exempt materials that are not of a truly proprietary nature under applicable law and policy, and cannot be held liable for the disclosure of such information, even if marked for restriction by an offeror.
3. If a proposal contains any information that an offeror reasonably believes is proprietary or confidential, and is subject to protection under applicable law, each such page of the proposal must be marked "Confidential" by the offeror and the offeror must explain the basis for its determination that the information is not subject to disclosure under applicable public records laws. Cost or price information may not be restricted and will be open to public inspection. Marking an entire proposal "confidential" is not acceptable and may result in disclosure of the entire proposal.
4. By submitting a proposal, the offeror agrees to release the District from any liability resulting from the District's disclosure of information not clearly marked "Confidential." The offeror also agrees to defend any action seeking release of information marked "Confidential" and to indemnify and hold the District, its Board, employees and agents, harmless from any judgments, damages and costs awarded against the District, its Board, employees or agents, in favor of a party requesting information submitted by an offeror. Additionally, the offeror understands and agrees that if a request is made under applicable public records laws, the District will notify the offeror of such request but under no circumstance shall the District be required to commence or defend any action to prevent the disclosure of any information submitted by an offeror, including information the offeror believes to be confidential or proprietary.

T. EQUAL EMPLOYMENT OPPORTUNITY

1. The Contractor certifies that it will not discriminate against any employee or applicant for employment because of race, color, religion, national origin, ancestry, age, sex, marital status, mental or physical disability, or change in marital status, in employment, provision of services or otherwise. The Contractor shall take affirmative action to ensure such non-discrimination, including but not limited to the following: employment, upgrading, demotion, transfer, recruitment or recruitment advertising, layoff or termination, rates of pay or other forms of compensation, and selection for training including apprenticeship. The Contractor shall post in conspicuous places, available to employees and applicants for employment, notices setting forth the provisions of this nondiscrimination clause.
2. The Contractor shall state, in all solicitations or advertisements for employees to work in the performance of this Agreement, that all qualified applicants will receive consideration for employment without regard to race, color, religion, national origin, ancestry, age, sex, marital status, mental or physical disability, or change in marital status.
3. The Contractor shall comply with the requirements of the Anchorage Municipal Code, Chapter 7.50.010-.120, as well as any procedures adopted by the District to implement the policies set forth therein.

4. The Contractor shall comply with any and all of the applicable laws and directives, and any regulations which may be applicable to the Project or this Agreement.
5. The Contractor shall include the provisions of this Article in every Subcontract and purchase order, and shall require each Subcontractor to include these provisions in every sub-subcontract, so that these provisions will be binding upon each Subcontractor, sub-subcontractor and vendor providing services or goods to the Project.
6. The Contractor shall cooperate fully with the District's efforts which seek to deal with the problem of unlawful discrimination, and with all other District efforts to guarantee fair employment practices under this contract and promptly comply with all requests and directions from the Anchorage Equal Rights Commission and State Commission for Human Rights or any of its officers or agents relating to prevention of discriminatory employment practices.

U. NON-DISCRIMINATION

1. No Contractor on any District contract may illegally discriminate on the basis of sex, race, color, religion, gender identity, sexual orientation, national origin, ancestry, age, marital status, changes in marital status, pregnancy, parenthood, physical or mental disability, Vietnam era veteran status, genetic information, or good faith reporting to the board on a matter of public concern in employment, provision of services, or otherwise.
2. Any Contractor submitting a bid or proposal of one hundred thousand (\$100,000) or more must certify that if awarded a contract on the basis of that bid or proposal, he/she as the contractor will not illegally discriminate against any member or applicant for employment because of sex, race, color, religion, gender identity, sexual orientation, national origin, ancestry, age, marital status, changes in marital status, pregnancy, parenthood, physical or mental disability, Vietnam era veteran status, genetic information, or good faith reporting to the board on a matter of public concern in employment, provision of services, or otherwise.

V. NOTICE OF COMPLIANCE

1. All successful Contractors shall ensure such non-discrimination.
2. All successful Contractors must agree to post in conspicuous places, available to employees and applicants for employment, notice setting forth the provisions of this non-discrimination section and this section shall be deemed to be a part of every contract entered into by the District under these policies.

W. CONFLICT OF INTEREST

1. The Contractor agrees to certify that Anchorage School District employees, School Board members, or a member of their household are not in conflict of interest with the contract and Board Policy as follows (AR3311.1(e).1 Disclosure and Waiver of Conflict of Interest):
 - a. No Board member, employee, or a member of their household, shall acquire, directly or indirectly, an economic interest in a District or Municipal contract, or engage in business with the District or the municipality, unless the contract is competitively solicited and other requirements of Section 3311 of Board Policy and section 1.15 of the Anchorage Municipal Code are met.
 - b. The following acts and circumstances shall not be deemed to be in conflict with the performance of official duties if, at the earliest opportunity after having acquired such knowledge, the Board member or employee files a disclosure pursuant to AR3311.1(e).1 or requests and obtains a waiver pursuant to Board Policy AR3311.1(e).2:

1. Such person owns a sole proprietorship, or is a partner in a partnership, or is an officer, director, major shareholder (five percent (5%) or more of the outstanding shares) or has management control in a corporation that submits a bid, proposal or quotation to the District or attempts to enter or enters into a contract with the District;
 2. Such person has any significant (five percent (5%) or more) financial interest in any sale, lease or rental to the District of any service or property and such person has knowledge that the District intends to purchase, lease or rent the property or service;
 3. Such person wishes to sell or receive royalties on books or materials sold to the District for use in the school system for which the employee is the author;
 4. Such person is an employee who has been providing private services to a child who transfers to a new school or class or advances to a higher grade and the child becomes a student in the class being taught/aided by his/her provider.
2. Board Members, District employees, and their household and/or immediate family members are required to comply with Board Policies and the Municipal Ethics Code by disclosing conflicts of interest.
- a. When a board member, employee, or their household and/or immediate family member intends to do business with the District, the appropriate District and Municipal forms must be filed by the Board Member or District employee with the Municipal Clerk's Office and the Purchasing Department.

Note: *Notice of Intent to Respond To Public Solicitation* shall be filed with the Municipal Clerk's office in advance to allow a minimum of **7 calendar days to elapse between electronic publication by the clerk and the final date** for submitting a response to the solicitation. The form may be obtained from the Municipality of Anchorage website, www.muni.org.

District *Disclosure* and *Request for Waiver* forms and instructions may be obtained from the Conflict of Interest link on the Procurement Department page of the ASD website, www.asdk12.org.

- b. The responsibility for complete and timely filing rests solely with the Board Member or District employee.

X. SEX OFFENDER/CHILD KIDNAPPER REGISTRY

Anchorage School Board Policy 3515.5 prohibits a contractor whose employees or agents may have direct or incidental contact with District students from sending any employee or agent to district property who has been convicted of a sex offense under federal law or the law of any state and who is required to register as a sex offender under Alaska law or by court order, or who has been convicted of child kidnapping under federal law or the law of any state and who is required under Alaska law or court order to register on the Alaska Department of Public Safety Sex Offender/Child Kidnapper Central Registry. Board Policy 3515.5 requires contractors to certify in writing the contractor's knowledge of and compliance with Board Policy 3515.5. **Prior to executing a contract** for this project, the selected Contractor shall verify that no employee or agent who will be on district property is registered as a sex offender or child kidnapper in Alaska [Alaska Department of Public Safety "Sex Offender/Child Kidnapper Registry"] or in any other state. In addition, the contractor shall certify that, to its knowledge, no employee or agent is a convicted sex offender or child kidnapper. Certification will be required at time of award.

Y. CONTACT WITH SCHOOL STAFF AND AUTHORIZED SCHOOL COMMUNITY GROUPS

Offeror is not to contact site's school staff or authorized community groups for purposes of solicitation unless otherwise authorized by the Purchasing Senior Director.

Z. CONTRACT INDUCEMENTS

No payment, gratuity or offer of employment shall be made in connection with any contract, by or on behalf of the subcontractor to the prime contractor or higher tier subcontractor or any person associated therewith, as an inducement for the award of a subcontract or order.

AA. STANDARD CONTRACT TERMS

In addition to carefully reading all of the information in the RFP, Offerors must carefully read and review the attached standard contract terms and conditions. The successful Offeror shall be required to enter into an agreement with the District which will be substantially similar to the sample.

END OF SECTION I

A. EVALUATION OF PROPOSALS

1. All proposals will be reviewed by the District's Purchasing Department to evaluate administrative responsiveness of proposals to determine if offerors have complied with the administrative proposal requirements and to determine if proposals meet the minimum mandatory criteria set forth below.
2. Proposals meeting minimum mandatory requirements then will be evaluated by an evaluation committee comprised of District employees or other persons deemed appropriate by the District using the Evaluation Criteria specified in this RFP. Evaluation of proposals in accordance with the evaluation criteria will result in a numerical score for each proposal. Each criterion has an assigned weight for this RFP which demonstrates its relative importance. Evaluation of proposals will be accomplished as follows:

- a. Each Evaluator will individually review and score each offeror's proposal on a scale of 0 to 1 for each of the Technical Evaluation Criteria.

A rating of "0" indicates a proposal which is non-responsive and/or provides no quality or value to the District and a rating of "1.0" indicates a proposal which is completely responsive and/or provides significant quality and value to the District. Ratings within the range indicate the level at which the proposal is responsive and/or provides quality and value to the District.

- b. After completion of ratings by each Evaluator, the Selection Committee may discuss the proposal. Evaluators may then alter their ratings; however, any changes shall be based only on the proposal and the Evaluation Criteria.
- c. The chairperson will obtain the ratings for the Evaluation Criteria, which ratings will then be multiplied against the points available for each criterion. The sum of the weighted scores for each proposal will result in a total weighted score from each member of the evaluation committee. The total weighted scores of all Evaluators will be summed to determine the total weighted score for each proposal. The maximum score obtainable for any proposal is equal to the product of the maximum points for the evaluation criteria multiplied by the number of Evaluators.
- d. Based upon the results of the proposal scoring, the District may, in its discretion, conduct discussions with offerors whose proposals are determined to be reasonably susceptible to award. Such discussions, visits and presentations are for the purpose of ensuring full understanding of the requirements of the RFP and offeror proposals and may not result in any material or substantive change to proposals. Offerors selected by the Selection Committee for interviews may be permitted to submit final written, graphic and verbal presentation information for consideration by the Selection Committee in response to the above purposes. Only those members of the offeror's staff who will be in responsible charge and/or will carry out the actual tasks should participate in the interviews.
- e. Subsequent to the interviews, the Selection Committee will make a final rating based upon the original criterion supplemented by interview information for the purposes of determining the highest ranked proposer. The Selection Committee shall use the same procedure as specified for the initial proposal rankings. The final ranking may or may not be the same as the order of ranking after completion of the initial ranking.
- f. For purposes of this RFP, proposals that are "reasonably susceptible to award" means the three (3) highest scoring proposals, unless, in the sole discretion of the District's Purchasing Senior Director, one or more of the three highest scoring proposals did not achieve a score high enough to be within the competitive range and to remain under

consideration for award when ranked with other proposals or the District received one or more additional proposals that are within the competitive range of the three highest scoring proposals such that the additional proposal(s) may remain under consideration when ranked with the other proposals. This is not a strict mathematical formula and may not be challenged on that basis except in the case of obvious arithmetic errors.

3. The District reserves the right, at any time, to determine that a proposal is non-responsive and to request additional information to determine responsiveness.
4. All Offerors will be advised of the offeror selected for negotiation with a Notice of Intent to Negotiate. If contract negotiations are unsuccessful with offeror selected for negotiation, the School District may either cancel the solicitation or negotiate with other offerors in the order of ranking.

B. EVALUATION CRITERIA

Proposals will be scored using the criteria listed below to determine which proposal best meets the needs of the Anchorage School District. The criteria to be considered during the evaluation and their associated weights are as follows:

Item	Criteria	Points
1.	PROJECT APPROACH	20
2.	METHODS	15
3.	MANAGEMENT	10
4.	FIRM'S EXPERIENCE	20
5.	PROPOSED PROJECT STAFF	20
6.	WORKLOAD AND RESOURCES	15
	TOTAL POINTS POSSIBLE	100

END OF SECTION II

Each response must be identified and keyed to the applicable criterion and assembled in the order in which the criteria are listed in Section II, Part B, so the criterion to which information applies shall be plainly evident. Material not so identified or assembled may be discarded without evaluation. Each proposal shall be submitted on standard 8 1/2" x 11" bond paper bound on one side. Proposals should be prepared simply and economically, providing a straightforward, concise delineation of the capabilities proposed to satisfy the requirements of this RFP. In addition, small print or typeface that is difficult to read may affect scoring.

To achieve a uniform review process and obtain the maximum degree of comparability, it is required that the proposals be organized in the manner specified below. **Proposals shall not exceed twenty (20) pages in length** (excluding letter of transmittal, resumes (resumes shall not exceed two (2) pages in length), table of contents, attachments, or dividers. Information in excess of those allowed will not be evaluated or scored. One page shall be interpreted as one side of single lined, typed, 8 1/2" X 11", piece of paper.

To ensure that proposals are evaluated fairly and that comparisons between proposals are accurate, Offerors must submit proposals in the format outlined below. Failure to comply with these requirements may cause a proposal to be rejected as non-responsive and eliminated from further consideration.

A. PROPOSAL TRANSMITTAL FORM

Submit the completed Proposal Transmittal Form (Attachment A) as the first page of the proposal per Site. The Proposal Transmittal Form must be signed by an authorized representative of the offeror.

B. PROPOSAL NARRATIVE

1. PROJECT APPROACH

Weight:

Restate the proposed Scope of Services, outlining the objectives and scope as perceived. Do not repeat the statement of services provided herewith, but elaborate on the tasks, conditions, deliverables or other specifics deemed significant and necessary to demonstrate a complete understanding of the technical and substantive issues to be addressed. Define any assumptions made in formulating response. If scope includes design services for a construction project, express any opinions regarding alternative design considerations that could impact construction costs.

2. METHODS

Weight:

Response must outline the methods for accomplishing the proposed contract. Consider what, when, where, how, and in what sequence the work will be done. Include proposed timeline with milestones. Identify the amount and type of work to be performed by any sub-consultants. Consider how each task may be carried out; what services or interaction may be required from/with the Contracting Agency. Suggest alternatives, if appropriate. Identify any distinct and substantive qualifications for undertaking the proposed contract, such as the availability of specialized equipment or unique approaches or concepts relevant to the required services, which the firms may use.

3. MANAGEMENT

Weight:

Response must describe the administrative and operational structures that will be used for performing the proposed contract. Address who will have overall responsibility for the contract and who will have direct responsibility for specific disciplines. Discuss the lines of authority. Use of a table or chart is preferred in your response. When applicable, include discussion of public participation process and coordination with State and Municipal agencies.

4. FIRM'S EXPERIENCE

Weight:

Discuss the offeror's background and qualifications to establish experience and performance as a team leader for professional services similar to those required by this project. Discuss the relevance of past projects (program, unique features, schedules, budgets, etc.) to this project. List at least three (3) references (contact persons and telephone numbers) for the firm.

5. PROPOSED PROJECT STAFF

Weight:

Response must name proposed leader(s) for the following categories plus any other essential personnel who will be directly and routinely engaged in performing the work:

1 – Principal-in-Charge	3 – Project Manager
2 – Contract Manager	4 – Project Engineer

Describe the work to be performed by the named Leader(s), and their qualifications in terms of educational and substantive experience directly related to the proposed services. Identify: employer, professional discipline and/or job classification, Alaskan registration number, and state of residency. A response prepared specifically for this proposal is required. Marketing resumes often include irrelevant information, which may detract from the evaluation of proposal. Lists of projects without relevant details are not useful. Focus on individuals' specific duties and responsibilities and how project experience is relevant to the proposed services.

6. WORKLOAD AND RESOURCES

Weight:

Response must: (1) discuss both current and potential time commitments to all clients (i.e., not only the District) for the proposed Project Staff; and (2) demonstrate adequate support personnel, facilities and other resources to provide the services required throughout the project's term. Briefly address capabilities for providing additional services and/or services under an accelerated schedule. Address capacity to reassign personnel, equipment and facilities whenever the proposed contract would not require such capabilities or would be delayed.

END OF SECTION III

A. SCOPE OF WORK

1. The requirements of this project shall consist of providing complete design services necessary to support installation of new generators at the location(s) identified below.
 - a. Bear Valley Elementary School – 15001 Mountain Air Dr. Anchorage, AK.
 - b. North Star Elementary School – 605 W. Fireweed Ln. Anchorage, AK.

This qualifications-based selection focuses on the Prime Consultant as the responsible and contractual leader of a team. The Offeror will only identify required disciplines in the proposal. Once selected and given a Notice of Intent to Negotiate by the School District, the Prime Consultant Offeror will proceed with a qualifications-based selection of Sub-consultants. The School District will consult with the Offeror, reviewing and commenting on proposed Sub-consultants as appropriate. The School District reserves the right to object to selection of Sub-consultants based on considerations of cost, performance, special qualifications, and/or known work load relative to resources.

The Prime Consultant is the project design coordinator and document quality control authority. Prime Consultant will review and verify deliverables prior to submission to Owner. Incomplete or lacking deliverables may be rejected. Owner will review complete deliverables for compliance and acceptance.

Each site will be negotiated and contracted separately.

2. **Planned Project Scope of Work: This project is funded by a Federal Emergency Management Agency (FEMA) Hazard Mitigation Grant Program (HMGP) grant. The District has been awarded phase 1 of the grant for development of the design and Benefit Cost Analysis (BCA) for the construction phase at both sites.**
 - a. Site Investigations for proper placement of exterior generator enclosures.
 - b. Design of new generators with the following characteristics:
 - i. Generator sized to run the entire school for the remainder of the school day if needed.
 - ii. Exterior enclosure for protection.
 - iii. Fuel tank sized for 24 hours of run time.
 - iv. Ability to automatically exercise the generator at a frequency determined by the Anchorage School District Maintenance Department.
 - c. Cost Estimates for development of Phase 2 grant request.
 - d. BCA for construction cost estimate using FEMA's BCA Toolkit.

B. SCOPE OF CONSULTANT SERVICES

For the purpose of this document, the phrase "Consultant(s)" refers to the person, partnership, corporation, joint venture, or other business entity with which the District contracts to provide the professional services required for this project.

Anticipated Scope of Consultant Services: For this project, the Consultant shall provide all professional services necessary to support the successful completion of this project. The Consultant's services shall include, but are not limited, to the following:

1. Consultant Design Phases/Deliverable Requirements: The following design phases with corresponding design deliverables shall be required for this project. See "Deliverables Checklist" (Appendix B, FPSA) and referenced District Design Guidelines for additional information on submittal requirements.

- a. Design Development Phase Submittal (65%)
- b. Bid Documents Submittal (100%)

2. Phase 1 Design Development

- a. Develop Project Scope and Design; Prepare Construction Drawings and Specifications with cost estimates
 - i. Verification of the Planned Project Scope of Work: As part of the Schematic Design Phase work, the Consultant shall verify and update the Planned Project Scope of Work. Consider sequencing and phasing of the work around the school's schedule, and provide recommendations. cursory review of the District's hazmat documentation will be necessary to ensure the project is viable and will remain within budget. The Consultant shall consult with the District Project Manager for any deviation from the Planned Project Scope of Work prior to completing the Schematic Submittal. Schematic Submittal shall reflect the final approved project scope of work. Value engineering and innovative design solutions are encouraged.
 - ii. Verification of the Construction Budget: The Consultant shall verify the project scope of work at each submittal with respect to required cost estimates at the 65% and 100% submittal. Prior to all milestone submittals, the Consultant shall verify to the District Project Manager that the cost estimate was reviewed and is reflective of the design document submittal. Should the project cost estimate reflect a design (scope of work) that is over the District's budget (CCAP), the Consultant shall, at the direction of the District Project Manager, make changes to arrive at the optimum design and bidding strategy by one of the follow or combination of methods. In general, it is expected the Consultant shall develop appropriate project scope at, or slightly exceeding, the available construction budget.
 - a. Adjust the design (scope of work) and/or propose additive alternates in consultation with the District Project Manager at no additional cost to the District
 - b. Revise the cost estimate at no additional cost to the District
 - iii. Project Design Review: ASD milestone Project Design Reviews are organized by the ASD PM and executed using Bluebeam Revu (Bluebeam) sessions at 65%, and 100% design phases. The use of Bluebeam allows for a collaborative, digital review for the Project; involving ASD Reviewers and Consultants, including the Consultant's cost estimator. ASD will provide all comments, written and noted, in the Bluebeam session and the Consultant shall assist the District by reviewing and responding in writing to all comments in the Bluebeam session; identifying and making written recommendations to the ASD Project Manager regarding the most critical design issues. The most critical path design issues will be summarized and discussed in a Post-Review Debrief (to be held at each design phase). The Project Manager will organize/invite Reviewers to the Post-Review Debrief. The Consultant shall act as the Meeting Facilitator of the Post-Review Debrief. The Post-Review Debrief is not meant to be a 'page-turn' review of design documents and comments, but a one-hour summarization of the most critical path items in design development and the team's intent/approach to resolve. Once the Post-Review Debrief is held, the PM will give Consultant notice to proceed to next design phase, pending any requested changes prior to NTP. The Project Manager will then verify that each comment and response has a Bluebeam **status** set and **finish** the Bluebeam session for ASD archives.
 - iv. Bidding and Permitting: The Consultant shall assist the District during the bidding and permit review of the project. During this phase of work, the Consultant's services shall include providing assistance during Municipality of Anchorage plan review and

construction permit application process [utilizing MOA electronic plans review protocols], attendance at pre-bid conference and pre-bid site visits, answering bidder's questions, and assisting the District in preparing necessary bid addendum. Provide all signed and stamped bid documents electronically on writable CD-ROM (drawings should be submitted in most current version of AutoCAD used by the Anchorage School District or as determined by ASD Project Manager and PDF versions).

3. Phase 2 Construction Administration & Closeout
 - a. Perform Construction Administration Services
 - i. The Consultant's services include attendance at the pre-construction conference and other scheduled meetings during construction.
 - ii. Review of submittals; respond to Requests for Information (RFIs), Potential Change Orders (PCOs), DCVRs, Information Bulletins, inspections, reviews of contractor pay requests, and review of closeout documentation.
 - iii. If part of the project, the consultant will participate in commissioning.
 - iv. Provide as-built Record Drawings and "Roof Section Schedule" (in Excel) electronically on CD-ROM. ASD will provide an Excel template for the "Roof Section Schedule". Provide both CAD and independent PDF files. Drawings shall be prepared using current ASD approved AutoCAD version and clearly identified as record drawings.
4. Anticipated Required Consultant Service Disciplines: Anticipated disciplines required for this project shall include, but are not limited to:
 - a. Electrical Engineering
 - b. Cost Estimating
5. Additional Requirements:
 - a. Reference Record Drawings: The Consultant shall research the District Plans Room records to identify important record drawings that may be issued with the Bid Documents as Reference Record Drawings or made available for viewing by the bidders at the District Plans Room. The Reference Record Drawings are intended to provide sufficient information to allow bidders to ascertain the physical conditions of the building including types of construction, building dimensions, etc. The Consultant shall prepare a Reference Record Drawing Cover Memo describing the reference record drawings. The cover memo shall include historical building and project information. If applicable, the Reference Record Drawing Cover Memo and the Reference Record Drawings shall be issued as part of the Bid Documents.
 - b. Use of the Anchorage School District Design Guidelines: Unless otherwise directed, the Consultant's designs and submittals shall conform to the requirements of the Anchorage School District Design Guidelines. The Consultant is advised the Anchorage School District Design Guidelines will be periodically updated. The Consultant's services and design shall conform to revisions to the Design Guidelines as they occur throughout the project.
 - c. Use of the Anchorage School District Guide Specifications: Unless otherwise directed, the Consultant shall utilize the Anchorage School District Guide Specifications as the basis for the technical specifications for this project. The Consultant is advised the Anchorage School District Guide Specifications will be periodically updated. The Consultant's services and design shall conform to revisions to the Guide Specifications as they occur throughout

the project.

- d. Services related to Construction Submittals: For this project, the District will develop a Submittal Register and a Submittal Status Log based on the developed project specifications. The applicable specification section shall be based on a guide specification section to be provided by the District. During construction, the Consultant shall be responsible for communications, the management of the Construction submittals, Requests for Information, construction record documents and photographs, and other purposes as directed by the Project Manager for the District utilizing owner-provided construction management software, currently Procure Construction Management. The Consultant shall receive the submittals directly from the Construction Contractor. Upon completion of the review of the submittals, one copy of the submittal shall be retained by the Consultant. The Consultant shall return the remaining copies of the submittals directly to the Construction Contractor.
- e. Extended District Review: The Consultant shall acknowledge that while review periods are scheduled during the design process, the District plan review resources may not be able to accommodate the schedule due to work load. In some cases, follow-up comments beyond the scheduled review period may be necessary. The Consultant is encouraged to be proactive in assisting the District in facilitating the design review process.
- f. Use of Standard Anchorage School District Invoice Format: The Consultant shall utilize a standardized Anchorage School District Invoice Format. The format will be provided by the District to the consultants.
- g. Technical Specifications Format: The Consultant shall utilize formatting standards for documenting technical specifications. The District will provide the standards format to the consultants.
- h. MOA Building Safety Pre-Application Meeting: At a minimum, one design pre-application meeting with the Municipality Building Safety officials at approximately 35% schematic design is required. The following disciplines are suggested to attend: electrical. Designer has responsibility to determine final list of disciplines required based on scope of project.

C. PROJECT SCHEDULE

Based on the Tentative Project Schedule and Specific Project Schedule Requirements below, the Offeror shall develop a preliminary project schedule covering the period from Notice to Proceed (NTP) through Design Completion based on anticipated workload and resources and include it as part of the Offeror’s proposal response to Part B, Article 2 Methods. Identify all submittal milestones including submittal dates, cost estimate submittal dates and District review comments periods.

1. Tentative Project Schedule for Design Work:

Requirement	Anticipated Dates
RFP/Consultant Selection/Negotiation:	July - August 2025
Anticipated Contract Award/NTP:	August 2025
65% Documents:	August - October, 2025
Final Construction Documents:	November 2025
Bid Period:	November 2025
Anticipated Construction Period:	Summer 2026 (depending on equipment delivery)
Record Documents:	October 2026 (depending on final closeout)

2. Specific Project Schedule Requirements:
 - a. Allow 2 weeks after each submittal for review by the District.

D. INFORMATION TO BE PROVIDED BY THE DISTRICT

The following information is available for review and use by the consultants during design:

1. Site Locations:
 - a. Bear Valley Elementary School – 15001 Mountain Air Dr. Anchorage, AK
 - b. North Star Elementary School – 605 W. Fireweed Ln. Anchorage, AK
2. Historical As-Built/Project Documents/AHERA Documents – Existing documents are available at the District Capital Planning & Construction Department. Proposers can view existing documents by coordination with the project support section for access to the plans room. Proposer must coordinate a time in advance with Capital Planning & Construction (CP&C) project support staff at 907-348-5215.

E. ADDITIONAL INFORMATION

1. Attachment C Bear Valley ES Site Plan.
2. Attachment D North Star ES Site Plan.

END OF SECTION IV

**THIS FORM MUST BE FILLED OUT COMPLETELY & RETURNED WITH EACH OFFEROR'S
PROPOSAL PER SITE**

NAME OF SITE: _____

Addendum Number(s)/Date(s) _____ is/are hereby
acknowledged.

**REPRESENTATION. THE OFFEROR REPRESENTS THAT IT [] IS, [] IS NOT A MINORITY BUSINESS
ENTERPRISE;**

AND/OR

**REPRESENTATION. THE OFFEROR REPRESENTS THAT IT [] IS, [] IS NOT A WOMEN BUSINESS
ENTERPRISE;**

AND/OR

REPRESENTATION. THE OFFEROR REPRESENTS THAT IT [] IS, [] IS NOT A LABOR SURPLUS AREA FIRM.

FIRM'S NAME: _____

MAILING ADDRESS: _____

CITY/STATE/ZIP: _____

PHYSICAL BUSINESS ADDRESS: _____

CITY/STATE/ZIP: _____

CONTACT PERSON FOR THIS SOLICITATION: _____

FAX NO.: _____

TELEPHONE NO.: _____

CELL PHONE NO.: _____

ALASKA BUSINESS LICENSE NO.: _____

FEDERAL TAX ID NO.: _____

EMAIL ADDRESS: _____

CERTIFICATION

I certify that I am a duly authorized representative of the firm listed above and that the information and materials enclosed with this proposal accurately represent the capabilities of the firm to provide the services indicated in compliance with the requirements of the solicitation. I certify that no member of the School Board or District employee, or spouse or other member of his/her household, has or shall have any undisclosed interest in the firm or this proposal, as provided in the Instructions to Offerors ("Conflicts of Interest"). The School District is hereby authorized to request from any individual any pertinent information deemed necessary to verify information regarding the capacity of the firm and for purposes of determining responsiveness of the proposal or responsibility of the firm as a prospective contractor. In compliance with the solicitation, the offeror agrees, if this offer is accepted within 90 calendar days from the date specified in the solicitation for receipt offers, to furnish any or all items on which prices are offered at the price set opposite each item, delivered at the designated places, within the times specified in the solicitation.

SIGNATURE: _____

PRINTED NAME AND TITLE: _____

DATE: _____

ANCHORAGE SCHOOL DISTRICT PROFESSIONAL SERVICES AGREEMENT (\$100,000 OR LESS)

	CONTRACT/P.O. NUMBER: DATE PREPARED:				
PROJECT TITLE: PROJECT NUMBER: CONTRACTOR:					
ASD PROJECT MANAGER:	PHONE NUMBER:				
ARTICLE 1 – SERVICES (DESCRIBED BELOW OR IN REFERENCED ATTACHMENT)					
1.1 Provide professional design services @					
ARTICLE 2 – PERIOD OF PERFORMANCE					
2.1 The Contractor shall commence the services described herein upon receipt of this fully executed Agreement and shall complete services @					
ARTICLE 3 – COMPENSATION					
3.1 Compensation for services shall not exceed the authorized amount(s) entered below and is in accordance with the attached proposals from @ dated @.					
Following completion of services and receipt of specific approval from the Anchorage School District, the Contractor shall submit one invoice. If the period of performance is in excess of three months, the Contractor may submit interim billings monthly, which represent the percentage of completed work for fixed-price work or substantiated charges for other than fixed-price work. The Contractor shall substantiate all charges other than for fixed price or fixed profit by attaching receipts, time sheets, summary of units completed, or other proof of expenditures.					
<u>Method of Payment</u> Fixed Price Time and Materials Unit Prices Salaries Expenses Hourly Rate TOTALS	<table border="1" style="width: 100%; height: 100%;"> <thead> <tr> <th style="text-align: center;"><u>Authorized Amount(s)</u></th> <th style="text-align: center;"><u>Funding Code(s):</u></th> </tr> </thead> <tbody> <tr> <td style="height: 100px;"></td> <td></td> </tr> </tbody> </table>	<u>Authorized Amount(s)</u>	<u>Funding Code(s):</u>		
<u>Authorized Amount(s)</u>	<u>Funding Code(s):</u>				
ARTICLE 4 – SIGNATORIES					
4.1 To this Agreement between the above-named Contractor and the Anchorage School District, effective on the last date executed by its parties, in consideration of the terms, conditions and requirements of Articles 1 through 6 herein, the parties hereto agree. (Incorporated Contractor must affix corporate seal or attach corporate resolution authorizing signatory to execute this Agreement.)					
<u>CONTRACTOR NAME</u>	<u>ANCHORAGE SCHOOL DISTRICT</u>				
SIGNATURE _____ NAME: TITLE:	SIGNATURE _____ NAME: David Whiting TITLE: Senior Director, Purchasing/Warehouse				
DATE _____	DATE _____				

ARTICLE 5 - INDEMNIFICATION AND INSURANCE

- 5.1 The A/E consultant shall obtain and maintain all insurance required under this section. The A/E consultant shall file with the Contracting Officer a Certificate of Insurance showing the type and amounts of insurance, the policy number, and the expiration date.
- 5.2 The A/E consultant shall indemnify, save and hold the Anchorage School District harmless for any and all claims that arise out of errors and omissions of the A/E consultant.
- 5.3 Certificates of Insurance shall be in the name of the Anchorage School District as an additional insured and shall provide the Contracting Officer, Anchorage School District, with at least a thirty (30) day written notice of any material change, cancellation or non-renewal of the policy(s) during the Contract Period.
- 5.4 Statement of Insurance. At the time of contract execution the A/E consultant must have in effect:

WORKER'S COMPENSATION	Statutory Limit	
EMPLOYER'S LIABILITY	\$1,000,000	
COMMERCIAL GENERAL LIABILITY	\$1,000,000	Combined Single Limit
	\$2,000,000	Aggregate Limit
COMPREHENSIVE AUTOMOBILE	\$1,000,000	per accident for any auto
PROFESSIONAL LIABILITY INSURANCE	\$100,000	<input type="checkbox"/> not required if checked

ARTICLE 6 - GENERAL CONDITIONS

- 6.1 Termination
 - 6.1.1 Termination - This Agreement may be terminated for just cause by either party upon ten days written notice. If warranted, the Contractor will be compensated for reasonable expenses incurred for services completed prior to the date of termination. Federal funding agency, if any, must approve any settlement in conformance with applicable federal regulations.
 - 6.1.2 Termination - The Anchorage School District may at any time terminate (convenience termination) or suspend this Agreement for its needs or convenience upon ten (10) Days' written notice to the Contractor. In the event of a convenience termination or a suspension of the Agreement for more than three (3) months, the Anchorage School District will compensate the Contractor for services performed and any expenditures incurred prior to the effective date of the written notice of termination or suspension. No fee, profit or other compensation for the uncompleted portion of the services will be paid, except for already incurred indirect costs which the Contractor can establish and for which the Anchorage School District would have compensated the Contractor over the life of this Agreement, but because of the termination or suspension would have to be absorbed by the Contractor without further compensation.
- 6.2 Officials not to Benefit - The Contractor shall comply with all applicable federal and state laws and regulations regarding ethical conduct of public officials and employees.
- 6.3 Independent Contractor - The Contractor and their agents and employees shall act in an independent capacity and not as officers or agents of the Anchorage School District in the performance of this Agreement except that the Contractor may function as the Anchorage School District's agent as may be specifically set forth in this Agreement.
 - 6.3.1 Any and all employees of this Contractor while engaged in the performance of any work or services required by the Contractor under this Agreement, shall not be considered employees of the Anchorage School District and any and all claims that may or might arise under the Worker's Compensation Act on behalf of said employees, while so engaged and any and all claims made by a third party as a consequence of any negligent act or omission on the part of the Contractor's employees, while so engaged on any of the services to be rendered herein, shall be the sole obligation and responsibility of the Contractor.

- 6.3.2 This Agreement will be declared null and void should the Anchorage School District determine that by Internal Revenue Service definitions employees of the Contractor or of any subcontractor may be an employee of the Anchorage School District.
- 6.4 Proselytizing - The Contractor agrees that it will not engage, on a full or part time basis, during the period of this Agreement, any person or persons who are or have been employed by the Anchorage School District during the period of this Agreement or during the 90 days immediately preceding the date of this Agreement except those who have been regularly retired or approved in writing by the Anchorage School District.
- 6.5 Covenant Against Contingent Fees - The Contractor shall comply with the Copeland "Anti-Kickback" Act (18 USC 874) as supplemented in federal Department of Labor Regulations (29 CFR, Part 3), which are incorporated by reference and made a part of this Agreement.
- 6.6 Subcontractors - The Contractor shall not engage any subcontractor(s) without the prior approval of the Anchorage School District.
- 6.7 No Assignment or Delegation - The Contractor may not assign or delegate this contract, or any part of it, or any right to any of the money to be paid under it, except with the written consent of the Anchorage School District.
- 6.8 Disputes - Any dispute concerning a question of fact arising under this Agreement which is not disposed of by mutual consent shall be decided without bias by the Anchorage School District which shall reduce the decision to writing and furnish a copy of it to the Contractor within 30 days of receipt of all necessary information from the Contractor upon which to base the decision. The Anchorage School District's decision is final and conclusive unless, within 30 days of receipt of the decision, the Contractor delivers a Notice of Appeal to the Anchorage School District. The Notice of Appeal shall include specific exceptions to the Anchorage School District's decision including specific provisions of this Agreement, which the Contractor intends to rely upon on appeal. General assertions that the Anchorage School District's decision is contrary to law or to fact are not sufficient. The Superintendent will appoint an Appeals Officer who will render a decision within 60 days of Notice of Appeal and the decision constitutes the exhaustion of contractual and administrative remedies.
- 6.9 Extent of Agreement/Changes - This Agreement represents the entire and integrated Agreement between the Anchorage School District and the Contractor and supersedes all prior negotiations, representations or agreements, written or oral. This Agreement may be changed only by written amendment executed by both the Anchorage School District and the Contractor.
- 6.10 Taxes - As a condition of performance of this Agreement, the Contractor shall pay all federal, state and local taxes incurred by the Contractor and shall require their payment by any other persons in the performance of this Agreement.
- 6.11 Governing Laws - This Agreement is governed by the laws of the State of Alaska and federal and local laws and ordinances applicable to the work performed. The Contractor shall be cognizant and shall at all times observe and comply with such laws which in any manner affect those engaged or employed in the performance, or which in any way affects the manner of performance, of this Agreement.
- 6.12 Ownership of Work Products
- 6.12.1 Ownership of Work Products produced under this Agreement, including items which have pre-existing copyrights, shall remain with the Contractor. The Anchorage School District shall have an unrestricted, irrevocable license to use the Work Products without infringing any copyrights, and without additional compensation to the Contractor.
- 6.12.2 Unrestricted use shall include use: (1) for any additions, alterations, or other subsequent work to the Project; (2) to demonstrate or reference conceptual arrangements, in whole or in part, for incorporation into any District project; and (3) reuse of a prototypical design on an Anchorage School District project.
- 6.12.3 Should the Anchorage School District elect to reuse Work Products produced by the Contractor and its Subcontractors under this Agreement and owned by the Contractor on any other project, the Anchorage School District shall indemnify, hold harmless and defend the Contractor and its Subcontractors against any damages or liabilities arising from such reuse.

- 6.12.4 When Work Products produced by the Contractor and its Subcontractors under this Agreement are reused by the Anchorage School District, the Contractor's and Subcontractors' signatures, professional seals and dates shall be removed. Such Work Products, which require professional signature and seal, will be signed, sealed and dated by the professional who is in direct supervisory control and responsible for the new project for which such Work Products are being reused.
- 6.12.5 The Contractor shall include this provision in every Subcontract so as to be binding on every Subcontractor.

6.13 Additional Provisions

- 6.13.1 Specifications provided by the Contractor shall follow the District's standards shown in attachment A to this document.
- 6.13.2 The following itemized Anchorage School District design guidelines and/or standards are in effect for this agreement. Should all or portions of subsequently issued standards be applicable to the project covered by this agreement, such standards will be issued by amendment.

Sample

1" Top
Margin

Layout
Margins
Normal: 1"

Header – Right align
Section Name, ALL CAPS, Font – Arial, size 10
Header from top setting should be 0.5"
Insert one return after Section Number

SECTION NAME

No Text Box or Table in
the Header or Footer

PART 1. GENERAL

Section Name
Font – Arial, size 10, ALL CAPS,
Centered, No Bolding

1.01 SECTION TITLE

Header/Footer Tab Tool Bar:
Different Odd & Even Pages
and/or Different First Page
should not be selected

A. Sentence case.

- 1. Sentence
- 2. Sentence

B. Sentence

1.02 SECTION TITLE

Body Text
Font – Arial, size 10.
Alignment: Justify

Paragraph Settings:
Before: 0 pt
After: 0 pt
Line Spacing: Single

Insert 1 blank line after PART and
between sub-paragraphs (except 1., 2.,
3., and a., b., c.)

Each bullet or numbered sub-paragraph
should be indented 1/2 inch

Indent PART Titles at 1 inch

1" Left
Margin

1" Right
Margin

END OF SECTION

END OF SECTION
Font – Arial, size 10 ALL CAPS,
Centered

Two (2) spaces above END OF
SECTION

No space before or after
Footer.

Footer Font – Arial, Size 9

Footer from Bottom setting
should be 0.5"

Abbreviate Elementary
School, Middle School and
High School in Footer only

No Text Box or Table in
the Header or Footer

Bottom Margin: 1"

In the Footer, set a Right Tab Stop at 6.5"
for Section/Page Number. This will be on the
same line as the Project Name.

After you type in the Section and Section
Number insert a "space, dash, space," and
Page number (Page X of Y, no Bolding) from
the Header/Footer Tool Bar.

Mountain Air Drive

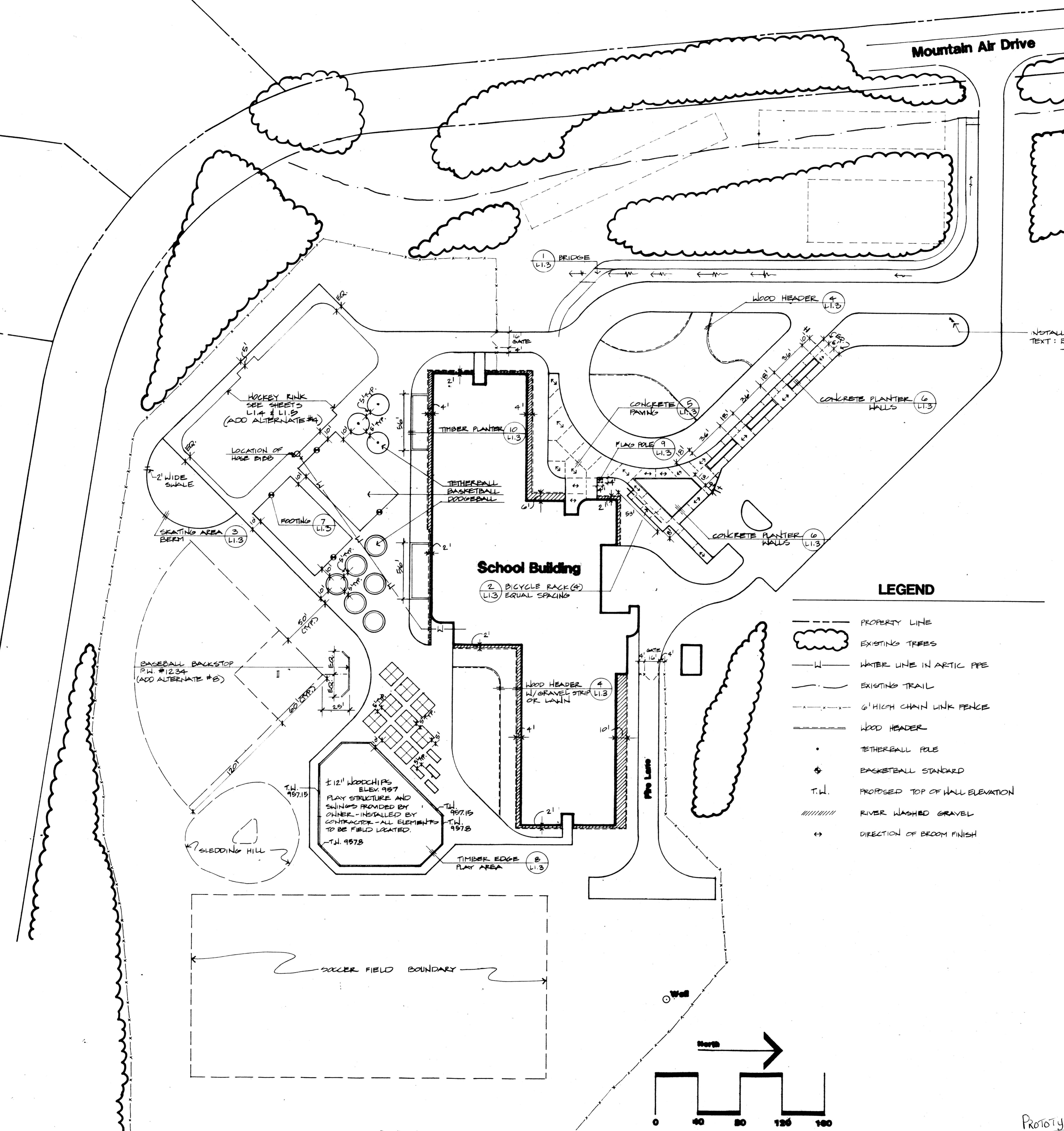

INSTALL METAL SIGN
 TEXT: BUSES ONLY

LEGEND

- PROPERTY LINE
- ☁️ EXISTING TREES
- W- WATER LINE IN ARTIC PIPE
- - - EXISTING TRAIL
- 6' HIGH CHAIN LINK FENCE
- WOOD HEADER
- TETHERBALL POLE
- ⊕ BASKETBALL STANDARD
- T.W. PROPOSED TOP OF WALL ELEVATION
- //// RIVER WASHED GRAVEL
- ↔ DIRECTION OF BROOM FINISH

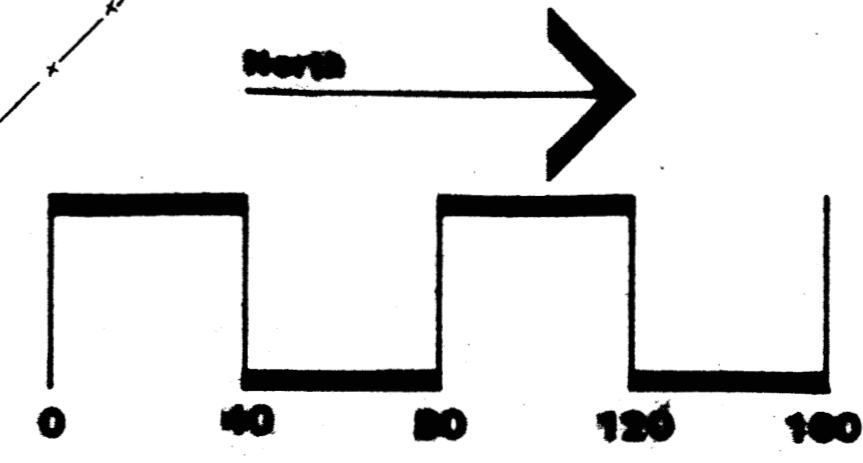

4.3	L1	F
	L1	F
	L1	F
	L1	F
	L1	F
	L1	F
	L1	F
	L1	F
	L1	F
	L1	F
	L1	F

PLANTING SCHEDULE				
BOTANICAL NAME	COMMON NAME	SIZE	QUANTITY	REMARKS
PICEA FUNGENS	COLORADO GREEN SPRUCE	6' - 8' HT.	34	
COTONEASTER ACUTIFOLIA	PEKING COTONEASTER	30" HT.	380	PLANT 24" O.C. TRIANGULAR SPACING
BETULA PAPHYRIFERA	ALASKA BIRCH	8'-10' HT.	4	PLANT 20'-0" O.C SPACING
CARAGANA ARBORESCENS	SIBERIAN PEA SHRUB	24"-36" HT.	117	PLANT 3'-0" O.C. TRIANGULAR SPACING
FINUS MUGO MUGO	MUGHO PINE	24" HT.	14	PLANT 4'-0"
PICEA FUNGENS	COLORADO GREEN SPRUCE	10' HT.	1	*

NOTES

THIS DRAWING HAS BEEN PREPARED BY USKH FROM INFORMATION AND DOCUMENTS SUPPLIED BY THE GENERAL CONTRACTOR OF THIS PROJECT. USKH DOES NOT CONFIRM THE ACCURACY OF THIS INFORMATION AND THEREFORE ASSUMES NO LIABILITY FOR ERRORS CONTAINED HEREIN.

BY: [Signature] DATE: 2.5.96

USKH
Architecture • Engineering
Land Surveying • Planning

2515 'A' St. Anchorage, Ak. 99503
(907)276-4245

1830 Second Ave. Fairbanks, Ak. 99701
(907)452-2128

Project:
NORTH STAR Elementary School
ANCHORAGE SCHOOL DISTRICT

Date	Revision	By
2-5-96	RECORD DRAWINGS	JC

Sheet Contents
LANDSCAPE PLAN

Project Mgr.	MAB	Sheet No.
Drawn	PRM	L1
Checked	KP JAH	
Date	6-11-95	

USKH no. 4216

LEGEND

PROPERTY LINE

11.4' STORM SEWER EASEMENT

20' SEWER EASEMENT

○ SITE LIGHTING - SEE CIVIL AND ELECTRICAL

— FENCE

EXISTING VEGETATION

○ EXISTING TREES
SIZE VARIES

PROPOSED VEGETATION

○ COLORADO GREEN SPRUCE, ALASKA BIRCH
MUGHO PINE

○ COTONEASTER

○ SIBERIAN PEA SHRUB

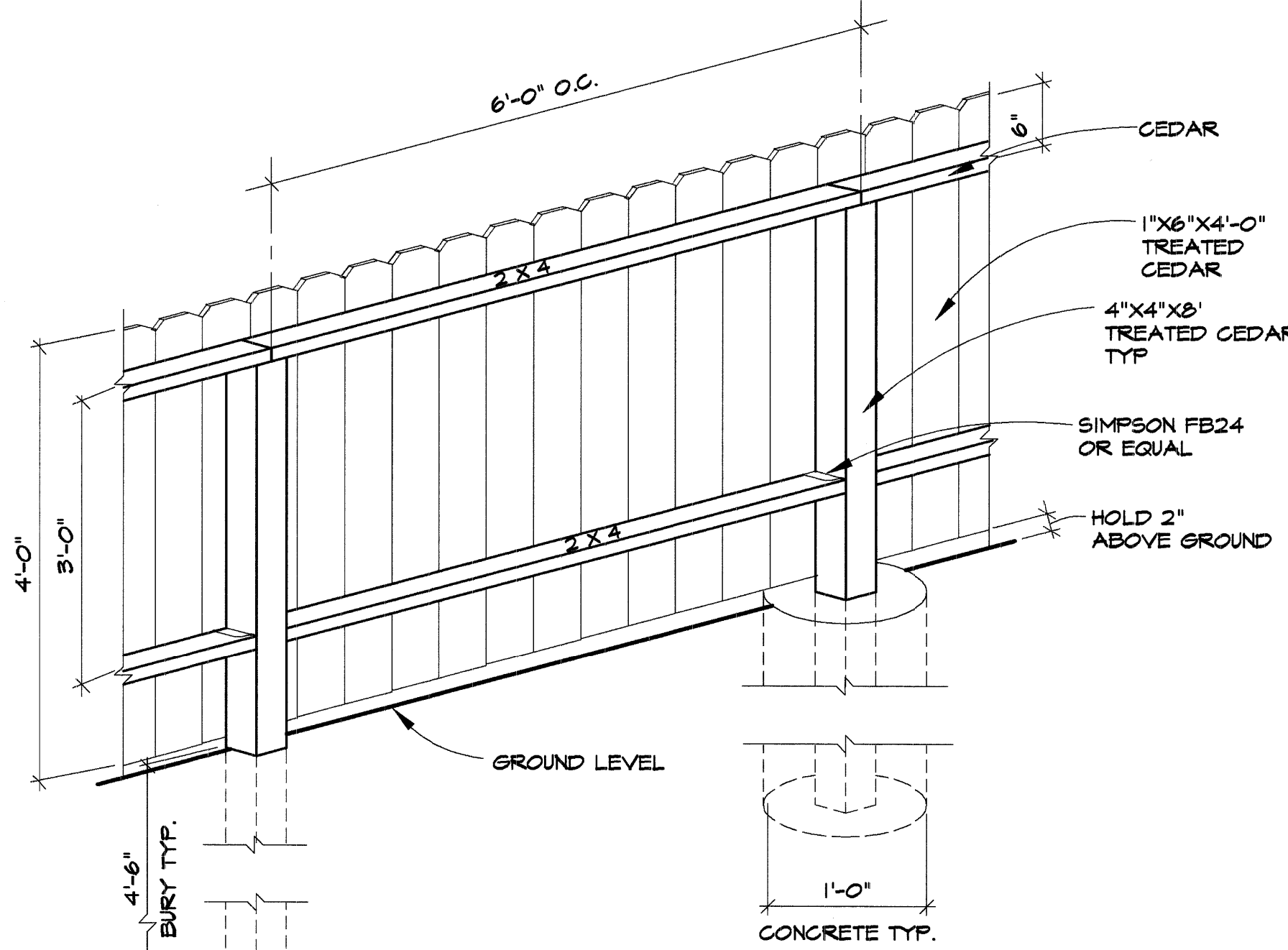
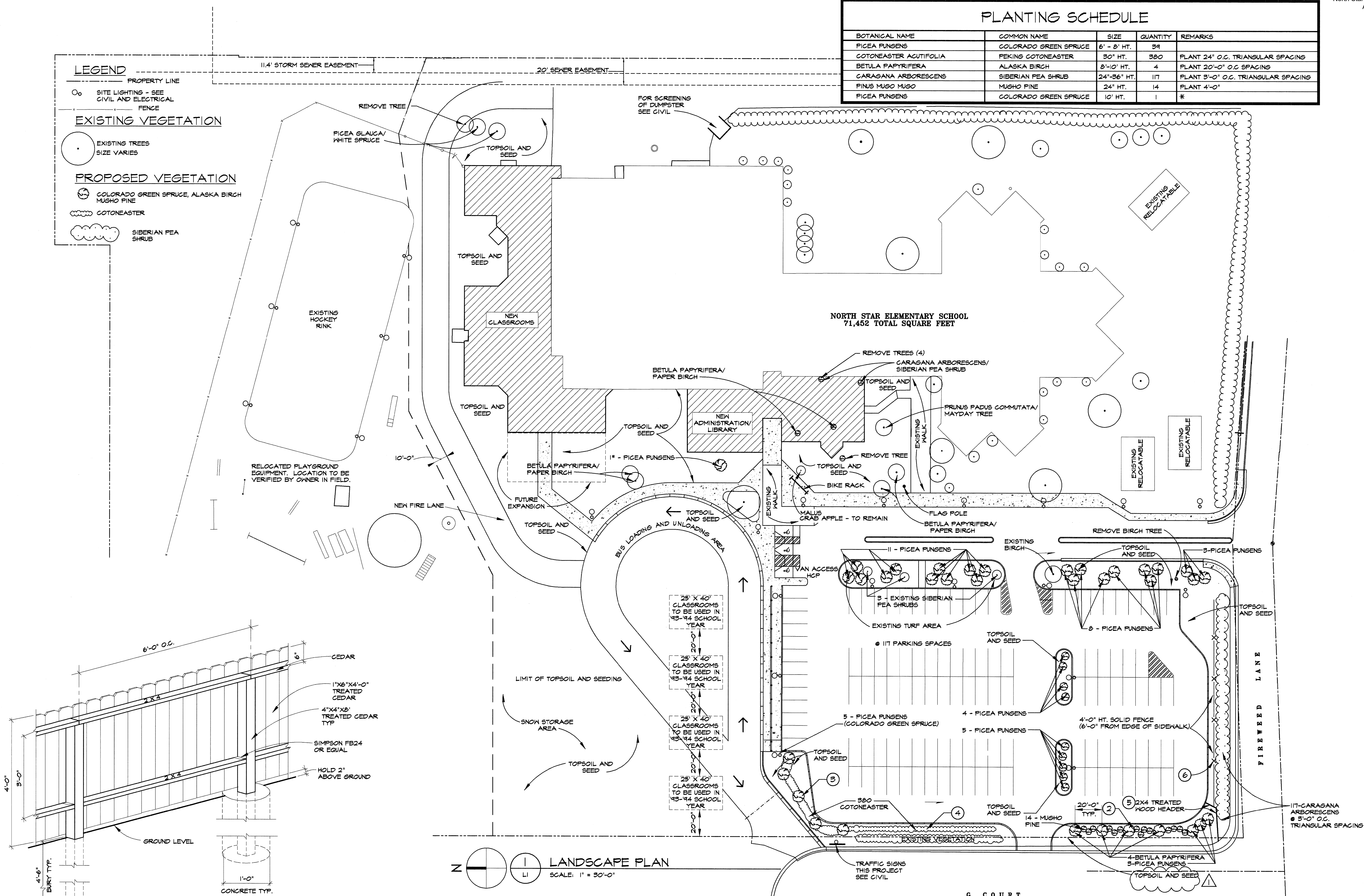

6 FENCE
LI SCALE: 3/4" = 1'-0"

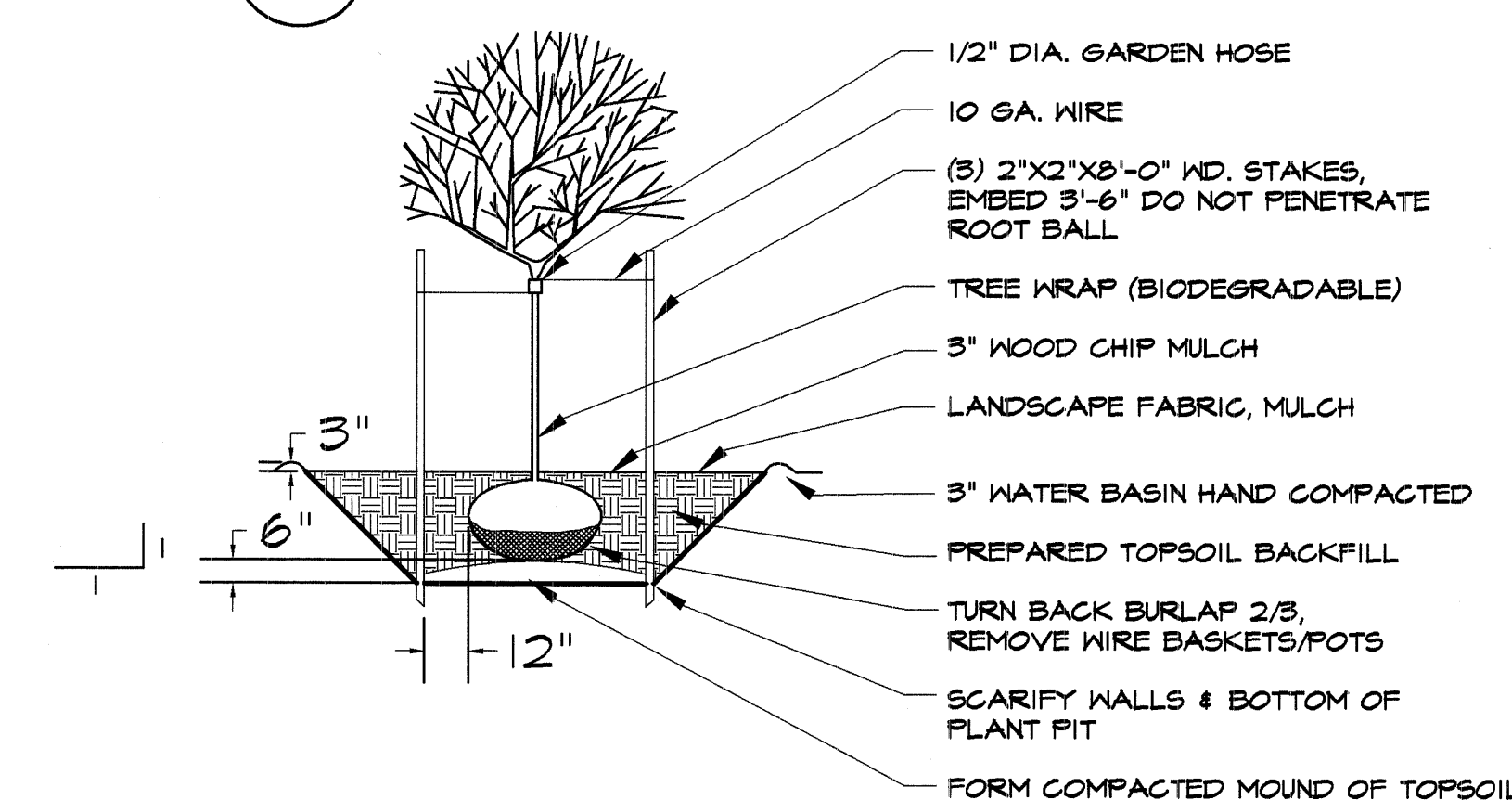

2 TYPICAL DECIDUOUS TREE PLANTING
LI SCALE: NTS

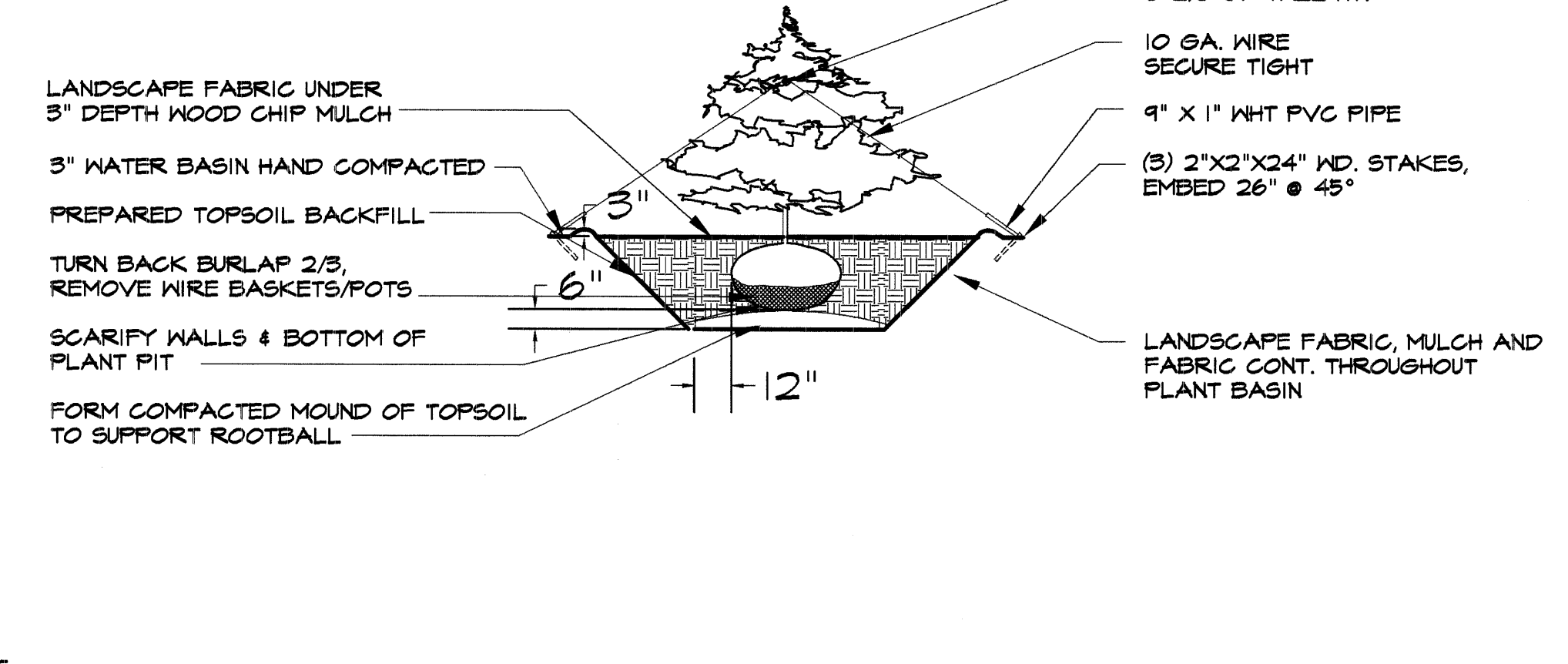

3 TYPICAL EVERGREEN TREE PLANTING
LI SCALE: NTS

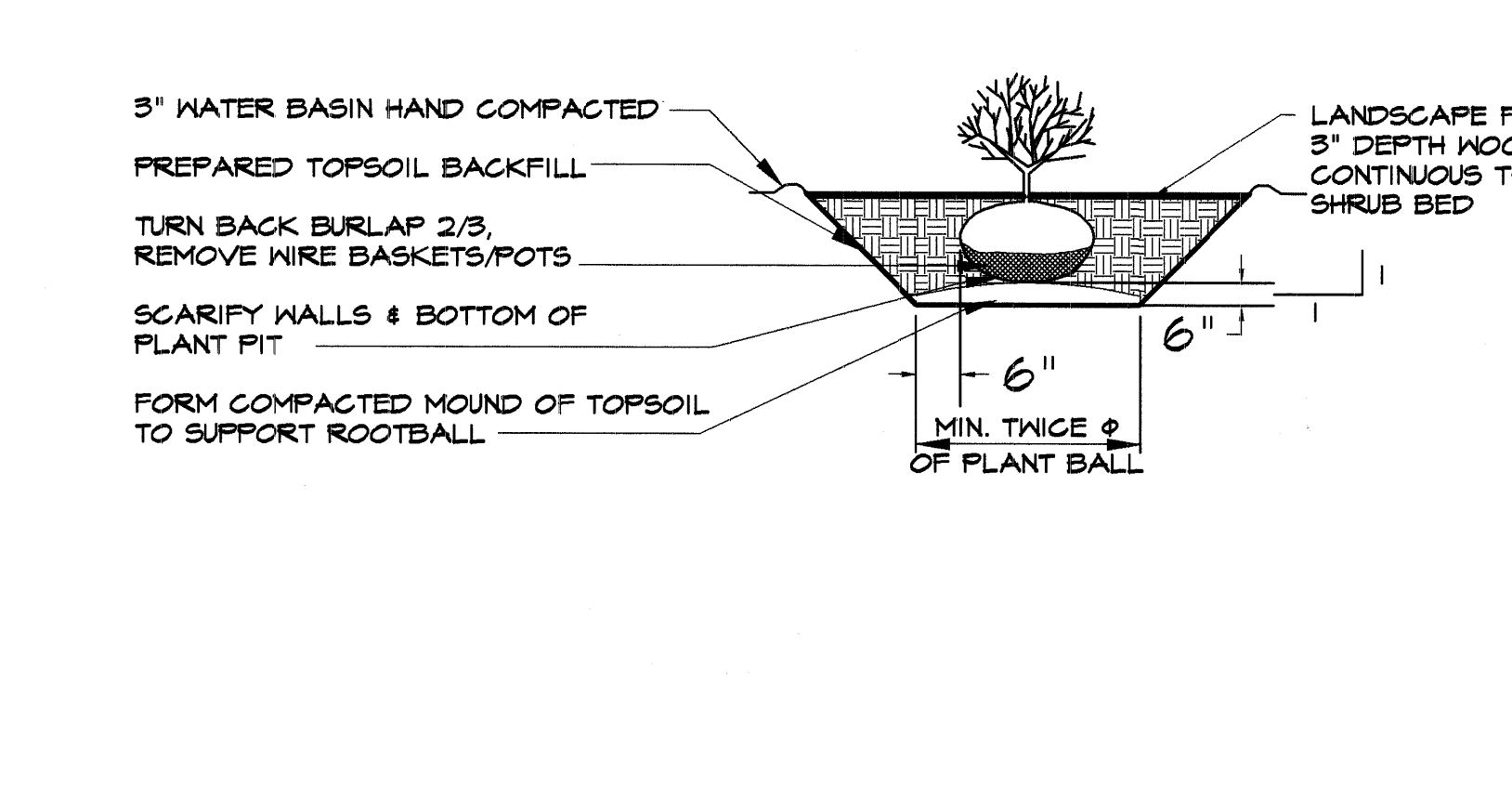

4 TYPICAL SHRUB PLANTING
LI SCALE: NTS

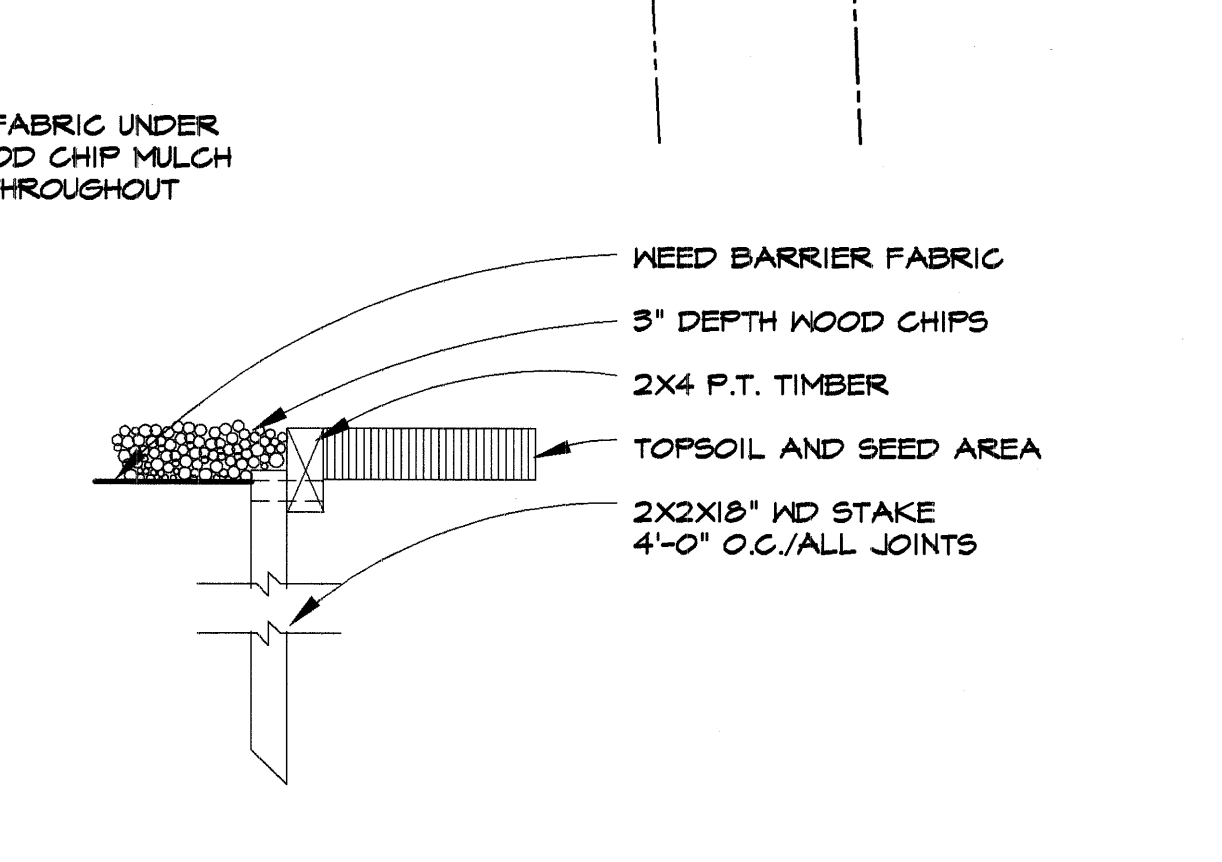

5 2X4 WOOD HEADER DETAIL
LI SCALE: NTS

FILE NAME: 4216LI PLOT SCALE: 1" = 30'

A. GENERAL

Proposers/Offerors are advised that, notwithstanding any instructions or implications elsewhere in this RFP, only the documents shown and detailed on this Check List need to be submitted with and made part of their proposal/offer. Proposers/Offerors are hereby advised that failure to submit the documents shown and detailed on this Check List may be justification for rendering the proposal/offer non-responsive.

B. REQUIRED DOCUMENTS FOR OFFER PROPOSAL SUBMISSION

1. Attachment A, Proposal Transmittal Form
Submit the completed Proposal Transmittal Form (Attachment A) as the first page of the proposal per Site.
2. All addenda issued should be acknowledged by manually signing the Addenda sheet and submitting it prior to the offer opening, or by indicating acknowledgement in the space provided on the Attachment A, Proposal Transmittal Form.

Items 3, 4, 5, & 6 TO BE SUBMITTED AS PART OF ORIGINAL PROPOSAL OR WITHIN THREE (3) CALENDAR DAYS OF NOTICE FROM THE DISTRICT IF NOT SUBMITTED WITH PROPOSAL.

DBE PARTICIPATION REQUIREMENTS MUST BE COMPLETED BY THE PROPOSAL SUBMISSION DATE.

ONLY 1 COPY OF 3, 4, 5 & 6 (below) is to be submitted.

3. Exhibit 1, Supplemental Term, Conditions and Forms
 - ✓ 1. Acknowledgement of Terms, Conditions, and Grant Clauses General Grant Clauses
 - ✓ 2. Certification Regarding Lobbying
4. Exhibit 2, Disadvantaged Business Enterprises, Contract Participation Form
5. Exhibit 3, Disadvantaged Business Enterprises, Prime Consultant/Contractor Certification
 - ✓ 1. Prime Consultant/Contractor Certification
6. Exhibit 4, Disadvantaged Business Enterprises, Contact Documentation Form
 - ✓ 1. Contact Documentation Form

EXHIBIT 1: SUPPLEMENTAL TERMS AND CONDITIONS

(2 C.F.R. § 200.326 and 2 C.F.R. Part 200, Appendix II, Required Contract Clauses)

The supplemental conditions contained in this section are intended to cooperate with, to supplement, and to modify the general conditions and other specifications **for the acquisition of supplies, services, equipment, or construction services to insure compliance with 2 C.F.R. § 200.317 through 200.327 and 2 C.F.R. Part 200, Appendix II** for contracts being awarded using Federal Grant funds.

1. Flow Down of Terms and Conditions from the Grant Agreement

Subcontracts: If the vendor Subcontracts any of the work required under this Agreement, a copy of the signed Subcontract must be forwarded to the Anchorage School District ("District") for review and approval. The vendor agrees to include in the Subcontract that (i) the Subcontractor is bound by the terms of this Agreement, (ii) the Subcontractor is bound by all applicable local, state and federal laws and regulations, and (iii) the Subcontractor shall hold the District harmless against all claims of whatever nature arising out of the Subcontractor's performance of work under this Agreement, to the extent allowed and required by law.

2. Compliance with Executive Order 11246 of September 24, 1965, entitled "Equal Employment Opportunity," as amended by Executive Order 11375 of October 13, 1967, and as supplemented in Department of Labor regulations

During the performance of this contract, the Contractor agrees as follows:

- (1) The Contractor will not discriminate against any employee or applicant for employment because of race, creed, color, or national origin. The Contractor will take affirmative action to ensure that applicants are employed, and that employees are treated during employment, without regard to their race, creed, color, or national origin. Such action shall include, but not be limited to the following: employment, upgrading, demotion, or transfer; recruitment or recruitment advertising; layoff or termination; rates of pay or other forms of compensation; and selection for training, including apprenticeship. The Contractor agrees to post in conspicuous places, available to employees and applicants for employment, notices to be provided by the contracting officer setting forth the provisions of this nondiscrimination clause.
- (2) The Contractor will, in all solicitations or advertisements for employees placed by or on behalf of the Contractor, state that all qualified applicants will receive consideration for employment without regard to race, creed, color, or national origin.
- (3) The Contractor will send to each labor union or representative of workers with which he has a collective bargaining agreement or other contract or understanding, a notice, to be provided by the agency contracting officer, advising the labor union or workers' representative of the Contractor's commitments under Section 202 of Executive Order No. 11246 of September 24, 1965, as amended by Executive Order No. 11375, and shall post copies of the notice in conspicuous places available to employees and applicants for employment.
- (4) The Contractor will comply with all provisions of Executive Order No. 11246 of Sept. 24, 1965, and of the rules, regulations, and relevant orders of the Secretary of Labor.
- (5) The Contractor will furnish all information and reports required by Executive Order No. 11246 of September 24, 1965, and by the rules, regulations, and orders of the Secretary of Labor, or pursuant thereto, and will permit access to his books, records, and accounts by the contracting agency and the Secretary of Labor for purposes of investigation to ascertain compliance with such rules, regulations, and orders.

- (6) In the event of the Contractor's noncompliance with the nondiscrimination clauses of this contract or with any of such rules, regulations, or orders, this contract may be cancelled, terminated or suspended in whole or in part and the Contractor may be declared ineligible for further Government contracts in accordance with procedures authorized in Executive Order No. 11246 of Sept 24, 1965, and such other sanctions may be imposed and remedies invoked as provided in Executive Order No. 11246 of September 24, 1965, or by rule, regulation, or order of the Secretary of Labor, or as otherwise provided by law.
- (7) The Contractor will include the *portion of the sentence immediately preceding the first paragraph* and the provisions of Paragraphs (1) through (7) in every Subcontract or purchase order unless exempted by rules, regulations, or orders of the Secretary of Labor issued pursuant to Section 204 of Executive Order No. 11246 of Sept. 24, 1965, so that such provisions will be binding upon each Subcontractor or Vendor. The Contractor will take such action with respect to any Subcontract or Purchase Order as the contracting agency may direct as a means of enforcing such provisions including sanctions for noncompliance: Provided, however, That in the event the Contractor becomes involved in, or is threatened with, litigation with a Subcontractor or Vendor as a result of such direction by the contracting agency, the Contractor may request the United States to enter into such litigation to protect the interests of the United States."
- (8) The contractor will include the portion of the sentence immediately preceding paragraph (1) and the provisions of paragraphs (1) through (8) in every subcontract or purchase order unless exempted by rules, regulations, or orders of the Secretary of Labor issued pursuant to section 204 of Executive Order 11246 of September 24, 1965, so that such provisions will be binding upon each subcontractor or vendor. The contractor will take such action with respect to any subcontract or purchase order as the administering agency may direct as a means of enforcing such provisions, including sanctions for noncompliance: Provided, however, that in the event a contractor becomes involved in, or is threatened with, litigation with a subcontractor or vendor as a result of such direction by the administering agency, the contractor may request the United States to enter into such litigation to protect the interests of the United States. The applicant further agrees that it will be bound by the above equal opportunity clause with respect to its own employment practices when it participates in federally assisted construction work: Provided that if the applicant so participating is a State or local government, the above equal opportunity clause is not applicable to any agency, instrumentality or subdivision of such government which does not participate in work on or under the contract. The applicant agrees that it will assist and cooperate actively with the administering agency and the Secretary of Labor in obtaining the compliance of contractors and subcontractors with the equal opportunity clause and the rules, regulations, and relevant orders of the Secretary of Labor, that it will furnish the administering agency and the Secretary of Labor such information as they may require for the supervision of such compliance, and that it will otherwise assist the administering agency in the discharge of the agency's primary responsibility for securing compliance. The applicant further agrees that it will refrain from entering into any contract or contract modification subject to Executive Order 11246 of September 24, 1965, with a contractor debarred from, or who has not demonstrated eligibility for, Government contracts and federally assisted construction contracts pursuant to the Executive Order and will carry out such sanctions and penalties for violation of the equal opportunity clause as may be imposed upon contractors and subcontractors by the administering agency or the Secretary of Labor pursuant to Part II, Subpart D of the Executive Order. In addition, the applicant agrees that if it fails or refuses to comply with these undertakings, the administering agency may take any or all of the following actions: Cancel, terminate, or suspend in whole or in part this grant (contract, loan, insurance, guarantee); refrain from extending any further assistance to the applicant under the program with respect to which the failure or refund occurred until satisfactory assurance of

future compliance has been received from such applicant; and refer the case to the Department of Justice for appropriate legal proceedings.

3. Davis Bacon Act (See Contract Provisions within Original Contract, if applicable); and Copeland Anti-Kickback Act (See Attached Certification, if applicable).

Note: In situations where the Davis-Bacon Act does not apply, neither does the Copeland "Anti-Kickback Act.

4. Contract Work Hours and Safety Standards Act of 1962, 40 U.S.C. 327 et seq.

The Contractor agrees it will require that mechanics and laborers (including watchmen and guards) employed on this federally assisted contract be paid wages of not less than one and one-half times their basic wage rates for all hours worked in excess of forty hours in a work week.

- (1) Overtime requirements. No contractor or subcontractor contracting for any part of the contract work which may require or involve the employment of laborers or mechanics shall require or permit any such laborer or mechanic in any workweek in which he or she is employed on such work to work in excess of forty hours in such workweek unless such laborer or mechanic receives compensation at a rate not less than one and one-half times the basic rate of pay for all hours worked in excess of forty hours in such workweek.
- (2) Violation; liability for unpaid wages; liquidated damages. In the event of any violation of the clause set forth in paragraph (b)(1) of this section the contractor and any subcontractor responsible therefor shall be liable for the unpaid wages. In addition, such contractor and subcontractor shall be liable to the United States (in the case of work done under contract for the District of Columbia or a territory, to such District or to such territory), for liquidated damages. Such liquidated damages shall be computed with respect to each individual laborer or mechanic, including watchmen and guards, employed in violation of the clause set forth in paragraph (b)(1) of this section, in the sum of \$26 for each calendar day on which such individual was required or permitted to work in excess of the standard workweek of forty hours without payment of the overtime wages required by the clause set forth in paragraph (b)(1) of this section.
- (3) Withholding for unpaid wages and liquidated damages. The (write in the name of the Federal agency or the loan or grant recipient) shall upon its own action or upon written request of an authorized representative of the Department of Labor withhold or cause to be withheld, from any moneys payable on account of work performed by the contractor or subcontractor under any such contract or any other Federal contract with the same prime contractor, or any other federally-assisted contract subject to the Contract Work Hours and Safety Standards Act, which is held by the same prime contractor, such sums as may be determined to be necessary to satisfy any liabilities of such contractor or subcontractor for unpaid wages and liquidated damages as provided in the clause set forth in paragraph (b)(2) of this section.
- (4) Subcontracts. The contractor or subcontractor shall insert in any subcontracts the clauses set forth in paragraph (b)(1) through (4) of this section and also a clause requiring the subcontractors to include these clauses in any lower tier subcontracts. The prime contractor shall be responsible for compliance by any subcontractor or lower tier subcontractor with the clauses set forth in paragraphs (b)(1) through (4) of this section.

5. Federal Fair Labor Standards Act, 29 U.S.C. Section 201 et seq.

The Contractor agrees it will require that covered employees be paid at least the minimum prescribed wage, and also that they be paid one and one-half times their basic wage rates for all hours worked in excess of the prescribed work-week.

6. Copeland “Anti-Kickback” Act (U.S.C. Section 51)

The Contractor agrees to comply with the Copeland Anti-Kickback Act of 1968, if applicable, which outlaws and prescribes penalties for “kickbacks” of wages in federally financed or assisted construction activities.

7. Reporting

The Contractor will provide any information requested by the District which is determined to be required to comply with 2 C.F.R. § 200 requirements and regulations pertaining to reporting.

8. Patents and Data

No reports, maps, or other documents produced in whole or in part under this contract shall be the subject of an application for copyright by or on behalf of the Contractor. The grantor agency and the grantee shall possess all rights to invention or discovery, as well as rights in data which may arise as a result of the Contractor’s services.

9. Clean Air Act, Federal Water Pollution Control Act, Executive Order 11738, and US EPA Regulations

Contracts and sub grants of amounts in excess of \$100,000 shall contain a provision that requires the Contractor or recipient to comply with all applicable standards, orders, or requirements issued under Section 112 and 306 of the Clean Air Act (42 U.S.C. § 1857 (h)), Section 508 of the Clean Water Act (33 U.S. 1368), Executive Order 11738, and the U.S. Environmental Protection Agency regulations (40 CFR Part 15 and 61). Violations shall be reported to the Federal awarding agency and the Regional Office of the Environmental Protection Agency (EPA).

10. Energy Conservation Requirements - 42 USC 6201

Energy Conservation - The Contractor agrees to comply with mandatory standards and policies relating to energy efficiency, which are contained in the state energy conservation plan issued in compliance with the Energy Policy and Conservation Act.

11. If appropriate to the project, the Contractor will provide assurances regarding the following:

- **Procurement of Recovered Materials.** The requirements of Section 6002 of the Solid Waste Disposal Act, Pub. L. No. 89.272 (1965) (codified as amended by the Resource Conservation and Recovery Act at 42 U.S.C. § 6962. The requirements of 6002 include procuring only items designated in guidelines of EPA 40 C.F.R. Part 247 that contain the highest percentage of recovered materials practicable, consistent with maintaining a satisfactory level of competition, where the purchase price of the item exceeds \$10,000.
 - a) In the performance of this contract, the Contractor shall make maximum use of products containing recovered materials that are EPA-designated items unless the product cannot be acquired –
 - i. Competitively within a timeframe providing for compliance with the contract performance schedule;
 - ii. Meeting contract performance requirements; or
 - iii. At a reasonable price.
 - b) Information about this requirement, along with the list of EPA-designate items, is available at EPA’s Comprehensive Procurement Guidelines website, <https://www.epa.gov/smm/comprehensive-procurement-guideline-cpg-program>.

THE FOLLOWING DOCUMENTS NEED TO BE RETURNED TO THE DISTRICT.

1. Acknowledgement of Terms, Conditions, and Grant Clauses
2. Certification Regarding Lobbying

Acknowledgement of Terms, Conditions, and Grant Clauses

Flow Down of Terms and Conditions from the Grant Agreement

Subcontracts: If the Vendor Subcontracts any of the work required under this Agreement, a copy of the signed Subcontract must be available to the Department for review and approval. The Vendor agrees to include in the Subcontract that (i) the Subcontractor is bound by the terms of this Agreement, (ii) the Subcontractor is bound by all applicable state and federal laws and regulations, and (iii) the Subcontractor shall hold the District harmless against all claims of whatever nature arising out of the Subcontractor's performance of work under this Agreement, to the extent allowed and required by law.

Grant Clauses

On behalf of my firm, I acknowledge, and agree to perform all of the specifications and grant requirements identified in this document.

Vendor/Contractor Name _____ Date _____

Authorized Signature _____

Email Address _____

Address/Phone Number

Contract Number _____

CERTIFICATION REGARDING LOBBYING
(Byrd Anti-Lobbying Amendment, awards over \$100,000)

The undersigned _____ (Vendor/ Contractor) certifies, to the best of his or her knowledge and belief, that:

(1) No Federal appropriated funds have been paid or will be paid, by or on behalf of the undersigned, to any person for influencing or attempting to influence an officer or employee of an agency, a Member of Congress, an officer or employee of Congress, or an employee of a Member of Congress in connection with the awarding of any Federal Contract, the making of any Federal grant, the making of any Federal loan, the entering into of any cooperative agreement, and the extension, continuation, renewal, amendment, or modification of any Federal Contract, grant, loan, or cooperative agreement.

(2) If any funds other than Federal appropriated funds have been paid or will be paid to any person for making lobbying contacts to an officer or employee of any agency, a Member of Congress, an officer or employee of Congress, or an employee of a Member of Congress in connection with this Federal Contract, grant, loan, or cooperative agreement, the undersigned shall complete and submit Standard Form--LLL, "Disclosure Form to Report Lobbying," in accordance with its instructions [as amended by "Government wide Guidance for New Restrictions on Lobbying," 61 Fed. Reg. 1413 (1/19/96). Note: Language in paragraph (2) herein has been modified in accordance with Section 10 of the Lobbying Disclosure Act of 1995 (P.L. 104-65, to be codified at 2 U.S.C. 1601, et seq.)]

(3) The undersigned shall require that the language of this certification be included in the award documents for all sub awards at all tiers (including Subcontracts, sub grants, and Contracts under grants, loans, and cooperative agreements) and that all sub recipients shall certify and disclose accordingly.

This certification is a material representation of fact upon which reliance was placed when this transaction was made or entered into. Submission of this certification is a prerequisite for making or entering into this transaction imposed by 31, U.S.C. § 1352 (as amended by the Lobbying Disclosure Act of 1995). Any person who fails to file the required certification shall be subject to a civil penalty of not less than \$10,000 and not more than \$100,000 for each such failure.

[Note: Pursuant to 31 U.S.C. § 1352(c)(1)-(2)(A), any person who makes a prohibited expenditure or fails to file or amend a required certification or disclosure form shall be subject to a civil penalty of not less than \$10,000 and not more than \$100,000 for each such expenditure or failure.]

The Vendor/Contractor, _____, certifies or affirms the truthfulness and accuracy of each statement of its certification and disclosure, if any. In addition, the Contractor understands and agrees that the provisions of 31 U.S.C. A 3801, et seq., apply to this certification and disclosure, if any.

_____ Signature of Vendor/Contractor's Authorized Official

_____ Name and Title of Vendor/Contractor's Authorized Official

_____ Date

EXHIBIT 2
Disadvantaged Business Enterprises
CONTRACT PARTICIPATION FORM

Efforts to Obtain MBE/WBE/LSAF Participation

- A. Please answer the following questions and return this questionnaire with attachments (i.e., ads, meeting attendance list, etc.) to the Purchasing Agent with your offer.

Project Name: _____
Solicitation Number: _____
Contractor: _____

- B. Did your company: YES/NO

1. Attend any pre-proposal meetings that were scheduled by the District? **Yes** No **N/A (provide documentation)**

If YES, please list the meetings (e.g. site-visit, pre-proposal conference, proposal reading) attended below.

- a)
- b)
- c)

2. Did your company utilize the services or assistance, as appropriate, of such organizations as the Small Business Administration, Alaska District Office, the Department of Transportation and Public Facilities (DOT), Civil Rights Office and/or the US Department of Labor?

Yes No **N/A (provide documentation)**

3. Advertise subcontracting opportunities in major circulation newspapers, such as:

- a) Anchorage Daily News?
- b) Pubic Website?
- c) Plans Rooms?
- d) Other types of notices?

Yes No **N/A (provide documentation)**

If YES, please attach copies of any ads or notices.

4. Provide timely written notice to specific MBEs/WBEs/LSAFs that their interest in the contract is being solicited? **Yes** No **N/A (provide documentation)**

If YES, please attach a sample of such notification and list MBEs/WBEs contacted on the Contact Documentation Form (Exhibit 4).

5. Follow-up initial solicitations of interest by personally contacting MBEs/WBEs/LSAFs? **Yes** No **N/A (provide documentation)**

If YES, please list those MBEs/WBEs/LSAFs contacted on the Contact Documentation Form (Exhibit 4).

6. Select the portions of the contract to be performed by MBEs/WBEs/LSAFs in a manner that will increase the likelihood of MBE/WBE/LSAF participation? **Yes** No **N/A (provide documentation)**

If YES, please attach a list of those portions of the contract selected for MBE/WBE/LSAF participation.

7. Provide interested MBEs/WBEs/LSAFs with timely and thorough information about the plans, specifications and technical requirements of the contract? **Yes** No **N/A (provide documentation)**

If YES, please list the MBEs/WBEs/LSAFs provided with such information on the Contact Documentation Form (Exhibit 4).

8. Negotiate in good faith with interested MBEs/WBEs/LSAFs, and not reject MBEs/WBEs/LSAFs as unqualified without sound reasons based on a thorough investigation of their capabilities? **Yes** No **N/A (provide documentation)**

If YES, list MBEs/WBEs/LSAFs with whom good faith negotiations were conducted on the Contact Documentation Form (Exhibit 4).

9. Assist interested MBEs/WBEs/LSAFs in obtaining bonding and/or insurance. **Yes** No **N/A (provide documentation)**

If YES, list MBEs/WBEs/LSAFs assisted on the Contact Documentation Form (Exhibit 4).

10. For each question answered "YES" above that requires a listing of MBEs/WBEs/LSAFs, please provide that listing on this page. Answers need not be limited to a single line. If more space is needed, please attach supplemental sheets. You need only list an MBE/WBE/LSA firm only once. Use the first column to indicate the question(s) referenced above by each firm listed. Any question answered "N/A" above, please provide supporting documentation of good faith efforts taken.

EXHIBIT 3
Disadvantaged Business Enterprises
PRIME CONSULTANT/CONTRACTOR CERTIFICATION

I. PROJECT INFORMATION

Applicant/Entity Name	Total of District Funding
Anchorage School District	\$

Prime Consultant/Contractor: _____
Contract Number: _____ **Contract Amount:** _____

II. AFFIRMATIVE STEPS (Applicant to all subcontracts awarded by the prime consultant/contractor)

I understand that it is my responsibility to comply with all state and federal regulations and guidance in the utilization of Minority, Women-Owned Businesses and Labor Surplus Area Firms in procurement. I certify that I will take affirmative steps to afford opportunities for Minority Business Enterprise (MBE), Women-Owned Business Enterprise (WBE) and Labor Surplus Area Firms (LSAF) by:

1. Including qualified MBEs/WBEs/LSAFs on procurement solicitation lists
 2. Soliciting potential MBE's/WBE's/LSAFs.
 3. Reducing contract size/quantities when economically feasible to permit maximum participation by MBE's/WBE's/LSAFs.
 4. Establishing delivery schedules to encourage participation by MBE's/WBE's/LSAFs.
 5. Using the services and assistance of the Small Business Administration, Minority Business Development Agency, U.S. Department of Commerce (<https://www.sba.gov/>), as appropriate, the Department of Transportation and Public Facilities (DOT), Civil Rights Office (<http://www.dot.state.ak.us/cvlrts/directory.shtml>) and/or the US Department of Labor (<http://www.doleta.gov/lssa>).
 6. Requiring all Prime Consultants/Contractors to follow steps 1-5 listed above in employing MBE/WBE/LSA Subcontractors.
- Exception:** As Prime Consultant/Contractor, I certify that I have reviewed the contract requirements and found no available subcontracting opportunities. I also certify that I will fulfill 100 percent of the contract requirements with my own employees and resources. (Check if applicable).

Signature – Prime Consultant/Contractor	Name & Title (print legibly)	Certification Date

III. DISTRICT APPROVAL SIGNATURE

Signature indicates the form meets DBE Requirements.

District Coordinator	Approval Date

EXHIBIT 4
Disadvantaged Business Enterprises
CONTACT DOCUMENTATION FORM

Project Name: _____ RFQ/ITB/RFP No. _____

Company Name: _____

This form is provided for your convenience to document your efforts to meet the DBE Affirmative Steps on this project. You may use additional sheets, if needed. You may return this form or other supporting documentation, such as explanations, advertising notices, solicitations, telephone logs, etc. with your Contract Participation Form (Exhibit 2).

Firm: _____ MBE / WBE / LSAF

Address: _____ Phone No: _____

Type of Work: _____ Amount: \$ _____

Dates of Contact: _____

Method of Contact: _____

Name of Person Contacted: _____

Results of Contact: _____

If rejected, why: _____

Firm: _____ MBE / WBE / LSAF

Address: _____ Phone No: _____

Type of Work: _____ Amount: \$ _____

Dates of Contact: _____

Method of Contact: _____

Name of Person Contacted: _____

Results of Contact: _____

If rejected, why: _____

Firm: _____ MBE / WBE / LSAF

Address: _____ Phone No: _____

Type of Work: _____ Amount: \$ _____

Dates of Contact: _____

Method of Contact: _____

Name of Person Contacted: _____

Results of Contact: _____

If rejected, why: _____

**Disadvantaged Business Enterprise Program
Program Specifications for District Contracts**

This project is a Federally funded contract and, is subject to any applicable federal and state regulations. Bidders/proposers shall be fully informed regarding the requirements of the regulations, statutes, and code regarding the Disadvantaged Business Enterprise Program (DBE).

A bidder/proposer who is determined not in compliance with the requirements of the applicable regulations and code, or these specifications will not be awarded this contract. Noncompliance after award of the contract constitutes a breach of the contract and may result in termination of the contract or other appropriate remedy for such breach.

Part I. Disadvantaged Business Enterprise Program Goals and Six Affirmative Steps.

All bidders/proposers shall solicit subcontractor or supplier bids/offers prior to bid/proposal opening for this project. The bidder/proposer acknowledges that post-bid/proposal opening of solicitations do not qualify for meeting Fair Share objectives or the Six Affirmative Steps.

- A. All bidders/proposers on this project **shall** carry out the required Six Affirmative Steps, listed as items 1 through 6 below:
 - 1. Include qualified small, minority, women's business enterprises, and labor surplus area firms on solicitation lists.
 - 2. Assure that small, minority, women's business enterprises, and labor surplus area firms are solicited. If the MBE/WBE is only certified as a Disadvantaged Business Enterprise (DBE), such as through the Small Business Administration (SBA), Alaska District Office; and the Alaska Department of Transportation and Public Facilities (DOT&PF), Civil Rights Office, and the bidder has exhausted all efforts to determine the subcontractor MBE/WBE status, the bidder may document either category of certification to meet the good faith efforts.
 - 3. Divide total requirements when economically feasible, into small tasks or quantities to permit maximum participation of small, minority, women's business enterprises, and labor surplus area firms.
 - 4. Establish delivery schedules, where requirements of the work permit, which will encourage participation by small, minority, women's business enterprises, and labor surplus area firms.
 - 5. Use the services and assistance of the U.S. Small Business Administration and the Minority Business Development Agency of the U.S. Department of Commerce, as appropriate.
 - 6. If the prime contractor or proposer awards subcontracts/procurements, require the subcontractor to take the affirmative steps 1 through 5 above.
 - 7. Exception: As prime consultant/contractor, certify that they have reviewed the contract requirements and found no available subcontracting opportunities; and certify that they will fulfill 100 percent of the contract requirements with their own employees and resources.
- B. The District will presume a lack of six affirmative steps to satisfy MBE, WBE and LSAF requirements if the bidder/proposer rejects any bids/offers from MBEs, WBEs and/or LSAF's, which are as low, or lower, than other competitor's bids/offers. The bidder/proposer that rejects an as-low or lower bid/offer from an MBE, WBE or LSAF may submit proof to rebut this presumption.
- C. If a prime contractor is an MBE, WBE or LSAF, such prime also must carry out the Six Affirmative Steps to award any subcontracts or procurements on this project.

- D. Record keeping requirements. The prime contractor must retain all records documenting their Six Affirmative Step for audit purposes and provide copies of these to the District DBE Officer upon request.

Apparent successful bidders/proposers, who fail to demonstrate completion of the required Six Affirmative Steps, will not be awarded this contract.

Part II: Certified Minority (MBE) and Women's (WBE) Business Enterprises

- A. MBE/WBE, or a joint-venture with a MBE/WBE, must be currently certified prior to opening of bids/proposals in order to be considered a MBE/WBE enterprise.
- B. Businesses must be certified by the Small Business Administration (SBA), Alaska District Office <https://www.sba.gov/offices/district/ak/anchorage>, Department of Transportation and Public Facilities (DOT), Civil Rights Office <http://www.dot.state.ak.us/cvlrts/directory.shtml>, or by state, local, Tribal or private entities whose certification criteria and who present proof of this will be eligible. Proof may be in the form of a letter from the certifying agency or a current listing in a directory maintained by the certifying agency.
- C. Those companies certified as DBEs by one of the agencies listed in Part II.B above:
1. Whose majority ownership and control is vested in one or more minority individuals;
 2. Whose majority ownership and control is vested in one or more non-minority women;
 3. Whose majority ownership and control is vested in one or more minority individuals, and who are women may be counted toward either the MBE or the WBE, but not to both.

Part III: MBE and WBE Participation

The MBE or WBE must perform work on the project in the category/categories of work for which certification is issued. While the MBE or WBE may perform work in other categories for which certification is not issued, only that work performed in the certified categories.

- A. The MBE or WBE must perform a useful business function according to custom and practice in the industry; i.e., must be responsible for the execution of a distinct element of work and must carry out its responsibilities by actually performing, managing, and supervising the work.
- B. An MBE or WBE that acts merely as a broker or passive conduit of funds, without performing, managing, or supervising the work of its contract or subcontract in a manner consistent with normal business practices.
1. Presumption. If 50% or more of the total dollar amount of MBE or WBE's prime contract is subcontracted to a non-DBE, the MBE or WBE prime contractor will be presumed to be a broker, and no MBE or WBE participation may be reported.
 2. Rebuttal. The MBE or WBE prime contractor may rebut this presumption by demonstrating that its actions are consistent with normal practices for prime contractors in its business and that it will actively perform, manage and supervise the work under this contract.
- C. MBE or WBE trucker/hauler expenditures will be credited towards the contract only if the trucker/hauler is performing a commercially useful function. The following factors should be used in determining whether MBE or WBE trucker/hauler is performing a commercially useful function:

1. The MBE or WBE must be responsible for the management and supervision of the entire trucking/hauling operation for which it is responsible on a particular contract, and there cannot be a contrived arrangement for the purpose of meeting MBE or WBE objectives.
 2. The MBE or WBE must itself own and operate at least one fully licensed, insured, and operational truck used on the contract.
- D. For joint ventures, MBE and WBE participation consists of the portion of the dollar amount of the joint venture attributable to the MBE or WBE. However, where the MBE/WBE's risk of loss, control or management responsibilities are not commensurate with the share of profit.

Part IV: Submission of Minority, Women's Business Enterprises and Labor Surplus Area Firms Information

- A. TO BE SUBMITTED AS PART OF BID/PROPOSAL OR WITHIN THREE (3) WORKING DAYS OF NOTICE FROM THE DISTRICT (ASD):
1. The bidder/proposer for this project shall submit their Contact Documentation (Exhibit 4), a completed and signed Prime Consultant/Contractor Certification (Exhibit 3) with their bid/proposal. If the bidder does not intend to utilize MBE, WBE or LSAF subcontractors, their Prime Consultant/Contractor Certification form must still be signed by bidder and, indicate "NONE TO BE USED". The bidder/proposal shall then be required to show that the mandatory Six Affirmative Steps were taken as set forth in these specifications, which are also included in the Contract Participation Form (Exhibit 2).
 2. Bids/offers submitted without a completed and signed Contract Participation Form, completed and signed Prime Consultant/Contractor Certification Form, and sufficient Contact Documentation will be considered non-responsive, if not submitted with bid/offer or upon three (3) working days upon request, if not submitted with their bid/proposal.
 3. A contract may not be awarded to a bidder/proposer who fails to submit the required supporting documents within the time specified. There shall be no substitutions, deletions, additions, or modifications to this listing subsequent to its submittal to Purchasing.

Part V: MBE/WBE/LSAF Utilization Removal/Substitution

If a successful bidder/proposer for a contract which contains MBE, WBE and/or LSA Firm participation requirements, at any time after award of contract, proposes to remove or make substitutions for MBE, WBE or LSA Firm subcontractors or joint-venture partners under the contract, a written notice of such removal or substitution shall be submitted to the District DBE Officer prior to commencement of performance of the affected work, with the names, addresses and phone numbers of the subcontractors or joint venture partners to be removed or substituted for and an explanation of the reasons for the removal and substitution. The successful bidder shall make good faith efforts as defined in Part I.B to utilize another MBE, WBE or LSA Firm subcontractor as the replacement. These efforts shall be documented and, the circumstances fully explained in writing, and approval obtained from the District DBE Officer prior to such replacement. The District DBE Officer shall, within seven (7) days of receipt of such notice, approve said notice or removal and substitution where it is shown that the requested action is for good cause and not for discriminatory purposes.

Part VI: Other Provisions

The District DBE Officer or his or her designee may visit the job site during regular working hours and interview subcontractors and employees for verification of compliance with these specifications and/or the regulations.

Part VII: Definitions

- A. Minority Business Enterprise (MBE) or Women Owned Business Enterprise (WBE) - means a business concern which is owned and controlled by one or more minorities or women. Owned and controlled means a business:
 - 4. Which is at least 51 percent owned by one or more minorities or women, or in the case of a publicly owned business, at least 51% of the stock is owned by one or more minorities or women;
 - 5. Whose management and daily business operations are controlled by one or more such individuals.
- B. Minority Individual - means an individual who is a citizen or lawful permanent resident of the United States and who is:
 - 1. Black (a person having origins in any of the black racial groups in Africa);
 - 2. Hispanic (a person of Mexican, Puerto Rican, Cuban, Central or South American, or other Spanish culture or origin, regardless of race);
 - 3. Portuguese (a person of Portugal, Brazilian, or other Portuguese culture or origin, regardless of race);
 - 4. Asian American (a person having origins in any of the original peoples of the Far East, Southeast Asia, the Indian subcontinent, or the Pacific Islands);
 - 5. American Indian and Alaskan Native (a person having origins in any of the original peoples of North America or original peoples of Alaska), and
 - 6. Members of other groups, or other individuals, found to be economically and socially disadvantaged by the United States Small Business Administration under section 8(1) of the federal Small Business Act.
- C. Labor Surplus Area (LSA) – is defined as a civil jurisdiction (a city of more than 25,000 or a county, borough, or census area) that has a civilian average annual unemployment rate during the previous two (2) calendar years of 20 percent or more above the average annual civilian unemployment rate for all states during the same 24-month reference period. If the national annual average unemployment rate during the referenced period is less than 6.0 percent, then the qualifying rate is 6.0 percent. If the national annual average unemployment rate during the referenced period is above 10 percent, then the qualifying rate is 10 percent. Please reference the US Department of Labor, Employment and Training Administration at <http://www.doleta.gov/lisa>. The list becomes effective each October 1 and remains in effect through the following September 30.
- D. Certification – a copy of a current MBE/WBE certification from any agency to be used for the District's monitoring of MBE/WBE participation in its program.
- E. Joint Venture – a commercial enterprise undertaken by more than one business enterprise jointly, limited in its scope and duration to one project, for the purpose of each enterprises profiting thereby.

- F. Fair Share - is a reasonable amount of funds commensurate with the total project funding, demographic factors and the availability of minority and women's businesses. A fair share does not constitute an absolute requirement, but a commitment on the part of the bidder/proposer to attempt to use minority and women's businesses by carrying out the "Good Faith Efforts".

For more information about these specifications, please contact the District DBE Officer at the Anchorage School District, Purchasing Warehouse, 4919 Van Buren Street, Anchorage, AK 99517; telephone (907) 742-8630.

Part VIII – Equal Opportunity, Minority, Women-Owned Business Enterprise and Labor Surplus Area Firm (MBE/WBE/LSAF) Participation

A. Equal Opportunity

No person or firm shall be discriminated against because of race, color, national origin, or sex in the award of District contracts. Further, the Contractor shall not discriminate on the basis of race, color, national origin, or sex in the performance of this contract.

B. MBE/WBE Participation

While there are no MBE/WBE/LSAF goals associated with this solicitation, the District is committed to achieving participation in its contracting programs by business enterprises that are owned and operated by minorities, women and labor surplus area firms (MBEs, WBEs and LSAF) regardless of the size of the enterprise. All bidders/offerors are strongly encouraged to take active steps to maximize the participation of MBEs, WBEs and LSAF in this contract.

C. Technical Assistance

The District will provide assistance to promote the participation of MBEs, WBEs and LSAF in this contract, including the identification of MBEs, WBEs and LSAF. To obtain assistance, interested parties are encouraged to contact the District's Purchasing Office at (907) 742-8621.